

ENERPAC 



BOLTING TOOLS

GB

E 4 1 5 e - 1

Enerpac's Bolting Solutions caters to the complete bolting work-flow, ensuring joint integrity in a variety of applications throughout industry:

Joint Assembly

From simple pipe alignment to complex joint positioning of large structural assemblies, our comprehensive line of joint assembly products range from hydraulic and mechanical flange alignment and flange closing tools to PLC-controlled multi-point synchronous positioning systems.

Controlled Tightening

Enerpac offers a variety of controlled tightening options to best meet the requirements of your application. From manual torque multipliers to hydraulic and pneumatic driven square drive wrenches, and from low profile hexagon torque wrenches to inter-connectable bolt tensioning tools; we offer the products you need for accurate and simultaneous tightening of multiple bolts.

Joint Separation

Enerpac also provides hydraulic nut splitters and a variety of mechanical and hydraulic spreading tools for joint separation during inspection, maintenance and decommissioning operations. High quality bolting solutions from the brand you can trust. See how Enerpac can make your bolting work-flow more accurate, safer and efficient.



Enerpac Bolting Integrity Software Solutions

Enerpac INFORMATE Bolting Integrity Software Solutions play a key role in implementing and managing an Integrity Program for bolted connections.

The software is used by a wide range of clients worldwide often interfacing with maintenance, construction and commissioning management systems.

The software offers Tool selection, Bolt Load calculations and Tool pressure settings, as well as, a combined Application Data Sheet and Joint Completion Report. Custom Joint information can also be entered.

Page: 142



Bolting Tools Overview

Tool Type and Function	Series	Page
Bolting Solutions		2-3
Torque Tools, Controlled Tightening & Loosening		4-54
Hydraulic Square Drive Wrenches	S	4-7
Heavy-Duty Impact Sockets	BSH	8
Back-Up Spanners	BUS	9
Safe T™ Torque Lock	STTL	10-11
Hydraulic Hexagon Wrenches	W	12-25
UltraSlim Stepped Width Cassettes	W-SL	22-23
Low Profile Hexagon Wrenches	RSL, RLP	26-35
Square Drive Hydraulic Wrenches	RSL, RSQ	36-37
Square Drive Hydraulic Wrenches	DSX	38-40
Modular Torque Wrenches	HMT	42-47
Hexagon Cassettes for HMT	HLP	44-45
Square Drive Cassettes for HMT	HSQ	46-47
Manual Torque Multipliers	E	48-49
Pneumatic Torque Wrenches	PTW	50-53
Mobile Calibration Stand	MCS	54
Torque Pumps		55-73
Selection Matrix Torque Pumps - Wrenches		55
Cordless Torque Pumps	XC	56-57
E-Pulse® Electric Torque Pumps	E	58-59
Electric Torque Pumps	TQ	60-61
Electric Torque Pumps	ZU4T	62-65
Electric Torque Pumps	ZE	66-67
Air Driven Torque Pumps	LAT	68-69
Air Driven Torque Pumps	ZA4T	70-75
Tensioning Tools & Pumps		76-96
HydraMax® Bolt Tensioners	HM	76-79
Topside Bolt Tensioners	GT	80-81
Aquajack Subsea Tensioners	EAJ	82-83
Power Generation Bolt Tensioners	PGT	84-85
Foundation Bolt Tensioners	FTR	86-87
Foundation Bolt Tensioners	FTE	88-89
Multi Stud Tensioners	MST	90
Hydraulic Nuts	HN	91
Ultra-High Pressure Hand Pump	HPT	92
Hoses and Couplers	HT, B	93
Electric Tensioning Pumps	ZUTP	94-95
Ultra-High Pressure Air Pump	ATP	96

Tool Type and Function	Series	Page
Joint assembly, positioning and separation		97-111
Power Box - Portable Tool Sets	SC, SL, SR, SW	97
Cylinder-Pump Sets	SC	98-99
Hydraulic Oil, Torque Hoses	HF, THQ	100
Wedgie and Spread Cylinders	A, WR	101
Flange Alignment Tools	ATM	102-103
Flange Spreading Wedges	FSC, FSH, FSM	104-105
Hydraulic Nut Cutters	NC	106-107
Hydraulic Nut Splitters	NSH, NSP	108-109
Mechanical Flange Face Tool	FF	110-111
Equalizer Flange Maintenance Tools		112-127
Introduction & Overview		112
Flange Spreading, Pin-Type	MG	113
Flange Spreading, Wedge-Type	SWi	114-117
Flange Spreading, Pulling-Type	SG	118-121
Valve Change-Out Tools	VC	122-123
Wind Tower Flange Alignment Tools	TFA	124
Flange Pulling Tools	FC	125
Hand Pumps and Hoses	HP, 144, 302	126
Training and Demonstration		127
Mirage Portable Machining Products		128-129
Piping Isolation and Test Tools	MITT	130-131
Bolting Yellow Pages		132-148
Introduction & Overview		132
Bolting Application Worksheet		133
Safety Instructions		134-135
Bolting Theory		136-137
Torque Tightening		138-139
Tensioning		140-141
INFORMATE Bolting Integrity Software	BSO	142-143
Hexagon Nut and Bolt Sizes		144
Key to Measurement		145
Bolting Service, Goal Zero, Safety		145
Enerpac Academy, Maintenance Program		147
About Enerpac & Enerpac On-Line		148
Modelnummer Index (Alphabetical)		

ATM-Series, Flange Alignment Tools



Misaligned joints

Joints must be pulled together and correctly aligned prior to tightening. Current methods of manipulation tend to be dangerous and involve a high degree of manual lifting using slings, hooks and lifting gear. These methods can damage joint components, are time consuming in setup and disassembly, operational time and the amount of manpower required.

Solution: Flange Alignment Tools

The Enerpac ATM-Series Flange Alignment Tools are developed to rectify twist and rotational misalignment without additional stress in pipelines. Hydraulic cylinders, jacks and lifting wedges can also be used to assist in positioning and aligning.

E-Series, Torque Multipliers



Controlled tightening when external power is unavailable

Applications are often located where external power sources to drive air or electric powered tools are unavailable but controlled bolting is required, typically at values higher than an operator can generate using manual wrenches.

Solution: Manual Torque Multipliers

Enerpac E-Series manual torque multipliers offer a range of output torques from manual inputs that can easily be achieved by an operator, providing accurate, efficient torque multiplication for make-up or break-out of joint fasteners.

S, W, RSL, DSX and HMT-Series, Torque Wrenches



Industrial Applications

Controlled tightening of multiple sized fasteners for industrial applications.

Solution: Hydraulic Torque Wrenches

Enerpac hydraulic torque wrenches are professional tools for industrial applications. Truly versatile tools which utilize standard Impact Sockets, optional direct Allen-Key Drives or interchangeable hexagon and square drive cassettes to provide controlled tightening of multiple sized fasteners per tool. Optional accessories further extend the application range of these products.

PTW-Series, Torque Wrenches



General Applications

Applications that require controlled bolting, feature a high volume of fastenings.

Solution: Pneumatic Torque Wrenches

Enerpac PTW-Series pneumatic torque wrenches are fast, easy to use and highly accurate.

Controlled Bolting

Increasing Health and Safety, Environmental and Productivity requirements demand even and parallel joint closure to ensure a sound assembly, especially on pressure containing vessels. This often requires the simultaneous tightening of multiple fasteners.

Solution: Hydraulic Bolt Tensioners

Enerpac Bolt Tensioners can achieve accurate preload in single or multiple fastener applications simultaneously, without inducing rotational twist or contending with the uncertainties of friction and lubrication. Power Generation Bolt Tensioners (PGT) and Foundation Bolt Tensioners (FTE, FTR) are also available.

HM, GT and EAJ-Series, Bolt Tensioners



Frozen or Corroded Nuts

Often nuts are difficult to remove, while loosening using tightening tools is possible, it generally requires larger equipment and is time consuming. The use of cutting torches or hammers and chisels can cause damage to the joint components, requires significantly longer setup and operational time, and can present a potential safety risk.

Solution: Hydraulic Nut Cutters

Nut splitting with the NC, NSC and NSH-Series Hydraulic Nut Cutters is the safest method. It takes less time and avoids costly damage to joint components. The head design fitted with heavy-duty chisels permits the splitting of nuts on a wide variety of applications. With the two blades models nuts are split from two side in one action.

NC, NSC and NSH-Series, Nut Cutters



Joint Separation

Separation of stubborn joints for inspection and maintenance, particularly those fitted with ring grooves or those with external forces acting on them are often difficult to separate. The use of hammers and wedges, chain blocks and lever bars can damage joint components and present a potential safety risk.

Solution: Flange Spreading Tools

Enerpac Wedge Spreaders and Flange Spreading Tools offer controlled separation without bending or risk of slipping from the joint. The SWi and SG-Series flange spreading tools can also be used.

FSC, FSH, FSM-Series, Wedge Spreaders



Pumps and Accessories

A wide range of torque and tensioning pumps and accessories are available including: manual, air, cordless and electric pumps, hoses, gauges, manifolds and fittings.

Enerpac Bolting Integrity Software Solutions

Comprehensive on-line software solutions for Bolted Joint Integrity. The software offers Tool selection, Bolt Load calculations and Tool pressure settings, as well as, a combined Application Data Sheet and Joint Completion Report. Custom Joint information can also be entered.

Pumps and Accessories Bolting Integrity Software



▼ Shown: S3000PX



Safety and Performance

- Compact, high-strength uni-body construction provides a small operating radius without sacrificing endurance
- 35° rotation angle and rapid return stroke for fast operation
- Tough manifold design with features for enhanced operator safety

Simplicity

- 360° click-on reaction arm with quick release lever provides easier handling, even with gloves on
- Includes robust handle or lifting eye which mounts on both sides of tool for extra maneuverability
- Push button square drive release for quickly reversing the square drive for tightening or loosening

Versatility

- Available with optional enhanced tilt and swivel TSP300 manifold for horizontal and vertical maneuverability, with greater durability ¹⁾

Accuracy

- Constant torque output provides accuracy of ±3% across full stroke
- Optional Angle-of-Turn Indicator provides measurement of rotation.

¹⁾ TSP300 is designed for X-Edition tools only, and is not compatible with previous edition tools. For replacement components for existing tools, refer to repair sheet on www.enerpac.com

Setting New Standards in Safety, Simplicity and Performance



Two Handle Styles

Robust angled positioning handle comes standard with every S-Series (X-Edition) tool. Straight positioning handles are available as accessories.

Compatible S-Series (X-Edition) wrenches	Model Nr. Angled positioning handles (standard)	Model Nr. Straight positioning handles (optional)
S1500X, S3000X	SWH6A	SWH6S
S6000X, S11000X	SWH10A	SWH10S
S25000X	SWH10EA ²⁾	

²⁾ SWH10EA is an eyebolt handle.



TSP - Pro Series Swivel

The optional TSP300 tilt and swivel manifold with robust interlocking design provides 360° X-axis rotation and 160° Y-axis rotation.

Page: **7**



ATEX-certified. Calibration certificate included

All S-Series X-edition tools are CE - ATEX certified and are shipped complete with a calibration certificate.

CE II 2 GD T4



Bolting Integrity Software

Enerpac Bolting Integrity Software Solutions play a key role in implementing and managing an Integrity Program for bolted connections. The software offers Tool selection, Bolt Load calculations and Tool pressure settings, as well as, a combined Application Data Sheet and Joint Completion Report. Custom Joint information can also be entered.

Page: **142**

X-Edition, Square Drive Hydraulic Torque Wrenches

Standard are: ① ② ⑥ ⑧
Other items are optional.

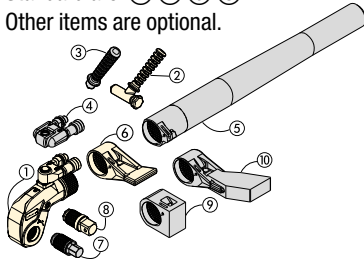

- ① Drive Unit
- ② Angeled Positioning Handle
- ③ Straight Positioning Handle
- ④ Pro Series Swivel
- ⑤ Reaction Tube Extension
- ⑥ Standard Reaction Arm
- ⑦ Allen Drive
- ⑧ Square Drive
- ⑨ Short Reaction Arm
- ⑩ Extended Reaction Arm

Select the Right Torque
Choose your Enerpac Torque Wrench using the untightening rule of thumb: Loosening torque equals about 250% of tightening torque.

S Series X-Edition



Nominal Torque Output:
35.455 Nm

Square Drive Range:
3/4 - 2 1/2 inch

Nose Radius:
25 - 64 mm

Maximum Operating Pressure:
690 bar

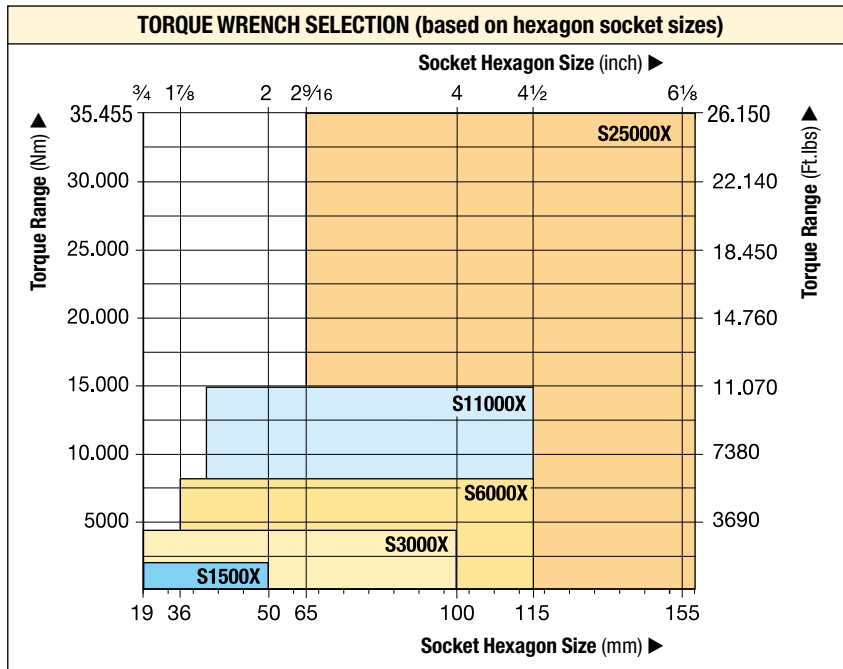

Back-Up Spanners
Hands free tool to be used to stop the back nut from turning during make up or break out.

Page: **9**

Use only Heavy Duty Impact Sockets
For power driven torquing equipment, according to ISO2725 and ISO1174; DIN 3129 and DIN 3121 or ASME-B107.2/1995.

Page: **8**

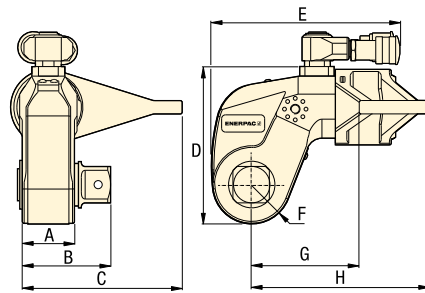

Safe T™ Torque Lock
The Safe T Torque Lock is suitable for all bolted applications from 190 Nm to 15.000 Nm using a heavy duty impact socket.

The patented mechanical locking system creates a hands-free torque wrench solution suitable for Enerpac only square drive tools.

Suitable for S3000X, S6000X and S11000X.

Page: **10**

Nominal Torque at 690 bar		Minimum Torque at 69 bar		Square Drive Size (inch)		Angle-of-Turn Model Nr. (optional)	Torque Wrench Model Number *	Dimensions (mm)								Weight (kg)
(Nm)	(Ft.lbs)	(Nm)	(Ft.lbs)	Model Nr. (included with wrench)	Model Nr. (optional)		A	B	C	D	E	F	G	H		
1952	1440	195	144	3/4	SD15-012	AOT15	S1500X	39	65	108	97	136	25	70	129	3,2
4373	3225	438	323	1	SD30-100	AOT30	S3000X	48	78	135	128	173	33	90	161	5,6
8338	6150	834	615	1 1/2	SD60-108	AOT60	S6000X	55	92	169	157	192	40	110	188	9,2
15.151	11.175	1516	1118	1 1/2	SD110-108	AOT110	S11000X	72	114	197	190	228	50	133	229	15,8
35.455	26.150	3545	2615	2 1/2	SD250-208	AOT250	S25000X	89	143	246	244	287	64	182	295	32,2

* To order a S-Series (X-edition) torque wrench fitted with a TSP300 tilt and swivel manifold, insert a "P" prior to the "X" in the tool model number, example: **S1500PX**.

Maximum Torque at 690 bar:

35.455 Nm

Hexagon Size Allen Drive:

1/2 - 2 1/4 inch

Hexagon Size Allen Drive:

14 - 85 mm

For
S
Series



Torque Wrench	Optional Allen Drives, Imperial				Optional Allen Drives, Metric				Short Reaction Arm for Allen Drives			
	Model Number	Hexagon Size ¹⁾ (inch)	Maximum Torque (Nm)	Model Number	Dim. B1 (mm)	Hexagon Size ¹⁾ (mm)	Maximum Torque (Nm)	Model Number	Dim. B1 (mm)	Model Number	Dimensions (mm) C1 H1	
S1500X (1952 Nm)		1/2	481	SDA15008	66	14	644	SDA1514	66	SRA15X	67,5	74
		5/8	936	SDA15010	67	17	1152	SDA1517	68			
		3/4	1620	SDA15012	71	19	1607	SDA1519	70			
		7/8	1952	SDA15014	74	22	1952	SDA1522	73			
		1	1952	SDA15100	77	24	1952	SDA1524	74			
S3000X (4373 Nm)		5/8	936	SDA30010	77	17	1152	SDA3017	77	SRA30X	80,0	74
		3/4	1620	SDA30012	80	19	1607	SDA3019	79			
		7/8	2569	SDA30014	83	22	2488	SDA3022	82			
		1	3830	SDA30100	86	24	3234	SDA3024	84			
		1 1/8	4373	SDA30102	88	27	4373	SDA3027	85			
		1 1/4	4373	SDA30104	89	30	4373	SDA3030	87			
		-	-	-	-	32	4373	SDA3032	88			
S6000X (8338 Nm)		5/8	936	SDA60010	85	17	1152	SDA6017	86	SRA60X	91,5	89
		3/4	1620	SDA60012	89	19	1607	SDA6019	88			
		7/8	2569	SDA60014	92	22	2488	SDA6022	91			
		1	3830	SDA60100	95	24	3234	SDA6024	93			
		1 1/8	5457	SDA60102	97	27	4603	SDA6027	94			
		1 1/4	7484	SDA60104	98	30	6311	SDA6030	96			
		-	-	-	-	32	7660	SDA6032	97			
S11000X (15.151 Nm)		1 1/4	7484	SDA110104	115	30	6311	SDA11030	112	SRA110X	127,5	106
		1 3/8	9958	SDA110106	117	32	7660	SDA11032	114			
		1 1/2	12.928	SDA110108	118	36	10.901	SDA11036	117			
		1 5/8	15.151	SDA110110	122	41	15.151	SDA11041	121			
		1 3/4	15.151	SDA110112	125	46	15.151	SDA11046	127			
S25000X (35.455 Nm)		1 1/2	12.928	SDA250108	141	36	10.901	SDA25036	140	SRA250X	158,5	135
		1 5/8	16.433	SDA250110	145	41	16.107	SDA25041	144			
		1 3/4	20.520	SDA250112	148	46	22.744	SDA25046	148			
		1 7/8	25.245	SDA250114	149	50	29.211	SDA25050	151			
		2	30.635	SDA250200	151	55	35.455	SDA25055	154			
		2 1/4	35.455	SDA250204	154	60	35.455	SDA25060	158			
		-	-	-	-	65	35.455	SDA25065	161			
		-	-	-	-	70	35.455	SDA25070	164			
		-	-	-	-	75	35.455	SDA25075	168			
		-	-	-	-	85	35.455	SDA25085	175			

¹⁾ See page 144 for table of hexagon sizes of bolts, nuts and related thread diameters.

Accessories for S-Series, X-Edition Wrenches

TSP RTEX SRSX Series



TSP-Series, Pro Series Swivel

- Robust interlocking design
- 360° X-axis and 160° Y-axis rotation
- Increases tool fit in restricted access areas
- Simplifies hose placement
- Includes male and female couplers

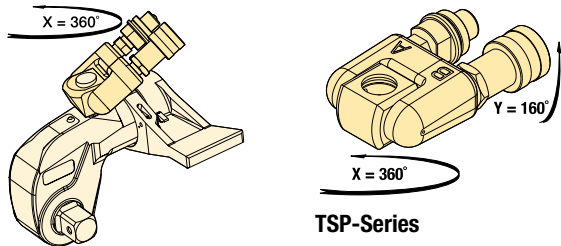

TSP-Series

For Torque Wrench Model Number	Model Number ¹⁾	Maximum Pressure (bar)	Weight (kg)
S1500X, S3000X, S6000X, S11000X, S25000X	TSP300	690	0,2

¹⁾ To order a S-Series (X-edition) torque wrench fitted with a TSP300 tilt and swivel manifold, insert a "P" prior to the "X" in the tool model number, example: **S1500PX**. TSP300 is designed for X-Edition tools only, and is not compatible with standard edition tools. For replacement components for existing tools, refer to repair sheet on www.enerpac.com

RTEX-Series, Reaction Tube Extensions

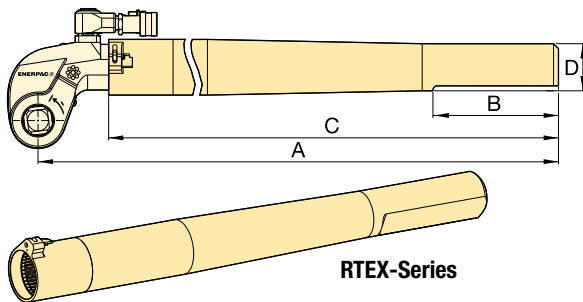

RTEX-Series

- Full torque rated
- Increases tool fit in restricted access areas

For Torque Wrench Model Number	Model Number	Dimensions (mm)				Weight (kg) *
		A	B	C	D	
S1500X	RTE15X	706	152	636	58	4,6
S3000X	RTE30X	733	152	647	57	5,5
S6000X	RTE60X	747	152	659	65	7,7
S11000X	RTE110X	769	152	675	76	11,2
S25000X	RTE250X	813	152	685	100	17,3

* Weights indicated are for the accessories only and do not include the wrench.

SRSX-Series, Extended Reaction Arms

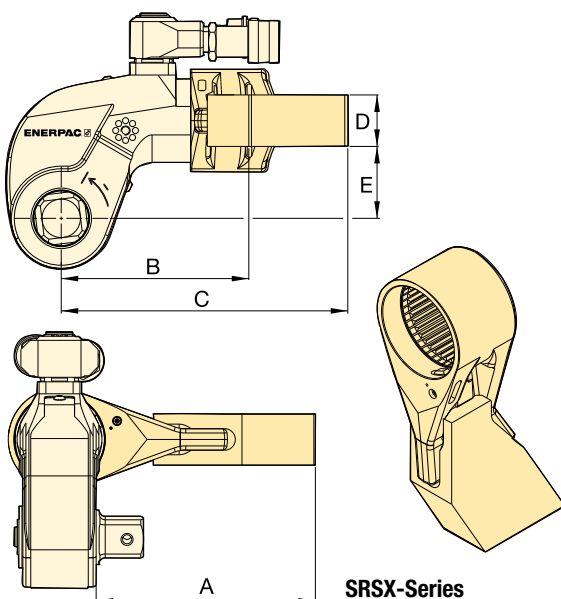

SRSX-Series

- Lightweight interchangeable design

For Wrench Model	Max. Torque (Nm)	Model Number	Dimensions (mm)					Weight (kg) *
			A	B	C	D	E	
S1500X	1801	SRS151X	94	86	127	24	34	0,8
	1641	SRS152X	119	97	138	24	34	1,0
	1533	SRS153X	145	109	148	24	34	1,2
S3000X	3918	SRS301X	111	106	168	34	48	1,6
	3712	SRS302X	137	117	182	34	48	2,0
	3574	SRS303X	162	132	198	34	48	2,5
S6000X	7842	SRS601X	138	128	192	39	62	2,3
	7454	SRS602X	163	144	207	39	62	2,7
	7175	SRS603X	189	159	222	39	62	3,4
S11000X	14.650	SRS1101X	149	157	232	46	76	4,4
	13.957	SRS1102X	175	172	247	46	76	5,1
	13.391	SRS1103X	200	187	261	46	76	5,8
S25000X	33.538	SRS2501X	183	209	295	50	100	7,6
	32.049	SRS2502X	208	222	310	50	100	8,4
	30.750	SRS2503X	233	236	326	50	100	10,0

* Weights indicated are for the accessories only and do not include the wrench.

- Heavy-duty impact sockets
- Supplied with "Pin and Ring"

BSH Series



Hexagon Sizes (A/F):

19 - 155 mm | 3/4 - 6 1/8"

METRIC SOCKETS							
3/4" Square Drive		1" Square Drive		1 1/2" Square Drive		2 1/2" Square Drive	
A/F (mm)	Model Number	A/F (mm)	Model Number	A/F (mm)	Model Number	A/F (mm)	Model Number
19	BSH7519	19	BSH1019	36	BSH1536	65	BSH2565
24	BSH7524	24	BSH1024	41	BSH15163	70	BSH2570
27	BSH7527	27	BSH1027	46	BSH1546	75	BSH2575
30	BSH7530	30	BSH1030	50	BSH1550	80	BSH2580
32	BSH7532	32	BSH1032	55	BSH1555	85	BSH2585
36	BSH7536	36	BSH1036	60	BSH1560	90	BSH2590
41	BSH75163	41	BSH10163	65	BSH1565	95	BSH2595
46	BSH7546	46	BSH1046	70	BSH1570	100	BSH25100
50	BSH7550	50	BSH1050	75	BSH1575	105	BSH25105
-	-	55	BSH1055	80	BSH1580	110	BSH25110
-	-	60	BSH1060	85	BSH1585	115	BSH25115
-	-	65	BSH1065	90	BSH1590	120	BSH25120
-	-	70	BSH1070	95	BSH1595	125	BSH25125
-	-	75	BSH1075	100	BSH15100	135	BSH25135
-	-	80	BSH1080	105	BSH15105	140	BSH25140
-	-	85	BSH1085	110	BSH15110	145	BSH25145
-	-	90	BSH1090	115	BSH15115	150	BSH25150
-	-	95	BSH1095	-	-	155	BSH25155
-	-	100	BSH10100	-	-	-	-

Select the Right Torque

250%

Choose your Enerpac Torque Wrench using the untightening rule of thumb: Loosening torque equals about 250% of tightening torque.

Page: 138

Hexagon Bolt and Nut Sizes

See the table of hexagon sizes of bolts, nuts and related thread diameters.

Page: 144

IMPERIAL SOCKETS													
3/4" Square Drive		1" Square Drive				1 1/2" Square Drive				2 1/2" Square Drive			
A/F (inch)	Model Number	A/F (inch)	Model Number	A/F (inch)	Model Number	A/F (inch)	Model Number	A/F (inch)	Model Number	A/F (inch)	Model Number	A/F (inch)	Model Number
3/4"	BSH7519	3/4"	BSH1019	2 5/16"	BSH10231	1 7/16"	BSH15144	2 13/16"	BSH15281	2 7/16"	BSH25244	4 3/16"	BSH25419
7/8"	BSH75088	7/8"	BSH10088	2 3/8"	BSH10238	1 1/2"	BSH1538	2 7/8"	BSH15288	2 1/2"	BSH25250	4 1/4"	BSH25425
1 5/16"	BSH75094	1 5/16"	BSH10094	2 7/16"	BSH10244	1 9/16"	BSH15156	2 15/16"	BSH1575	2 13/16"	BSH2565	4 5/16"	BSH25110
1 1/16"	BSH7527	1 1/16"	BSH1027	2 1/2"	BSH10250	1 5/8"	BSH15163	3"	BSH15300	2 5/8"	BSH25263	4 3/8"	BSH25438
1 3/16"	BSH7530	1 3/16"	BSH1030	2 9/16"	BSH1065	1 11/16"	BSH1543	3 1/16"	BSH15306	2 11/16"	BSH25269	4 1/2"	BSH25450
1 1/4"	BSH75125	1 1/4"	BSH10125	2 5/8"	BSH10263	1 3/4"	BSH15175	3 1/8"	BSH15313	2 3/4"	BSH2570	4 5/8"	BSH25463
1 5/16"	BSH75131	1 5/16"	BSH10131	2 11/16"	BSH10269	1 13/16"	BSH1546	3 3/16"	BSH15319	2 11/16"	BSH25281	4 3/4"	BSH25475
1 3/8"	BSH7535	1 3/8"	BSH1035	2 3/4"	BSH1070	1 7/8"	BSH15188	3 1/4"	BSH15325	2 7/8"	BSH25288	4 7/8"	BSH25488
1 7/16"	BSH75144	1 7/16"	BSH10144	2 13/16"	BSH10281	1 15/16"	BSH15194	3 3/8"	BSH15338	2 15/16"	BSH2575	5"	BSH25500
1 1/2"	BSH7538	1 1/2"	BSH1038	2 7/8"	BSH10288	2"	BSH15200	3 1/2"	BSH15350	3"	BSH25300	5 1/8"	BSH25513
1 9/16"	BSH75156	1 9/16"	BSH10156	2 15/16"	BSH1075	2 1/16"	BSH15206	3 5/8"	BSH15363	3 1/16"	BSH25306	5 3/16"	BSH25519
1 5/8"	BSH75163	1 5/8"	BSH10163	3"	BSH10300	2 1/8"	BSH15213	3 3/4"	BSH1595	3 1/8"	BSH25313	5 1/4"	BSH25525
1 11/16"	BSH7543	1 11/16"	BSH1043	3 1/16"	BSH10306	2 3/16"	BSH15219	3 7/8"	BSH15388	3 3/16"	BSH25319	5 3/8"	BSH25538
1 3/4"	BSH75175	1 3/4"	BSH10175	3 1/8"	BSH10313	2 1/4"	BSH15225	3 15/16"	BSH15100	3 1/4"	BSH25325	5 1/2"	BSH25140
1 13/16"	BSH7546	1 13/16"	BSH1046	3 3/16"	BSH10319	2 5/16"	BSH15231	4"	BSH15400	3 3/8"	BSH25338	5 3/4"	BSH25575
1 7/8"	BSH75188	1 7/8"	BSH10188	3 1/4"	BSH10325	2 3/8"	BSH15238	4 1/8"	BSH15105	3 1/2"	BSH25350	5 7/8"	BSH25150
1 15/16"	BSH75194	1 15/16"	BSH10194	3 3/8"	BSH10338	2 7/16"	BSH15244	4 3/16"	BSH15419	3 5/8"	BSH25363	6"	BSH25600
2"	BSH75200	2"	BSH10200	3 1/2"	BSH10350	2 1/2"	BSH15250	4 1/4"	BSH15425	3 3/4"	BSH2595	6 1/8"	BSH25613
-	-	2 1/16"	BSH10206	3 5/8"	BSH10363	2 9/16"	BSH1565	4 5/16"	BSH15110	3 7/8"	BSH25388	-	-
-	-	2 1/8"	BSH10213	3 3/4"	BSH1095	2 5/8"	BSH15263	4 3/8"	BSH15438	3 15/16"	BSH25100	-	-
-	-	2 3/16"	BSH10219	3 7/8"	BSH10388	2 11/16"	BSH15269	4 1/2"	BSH15450	4"	BSH25400	-	-
-	-	2 1/4"	BSH10225	-	-	2 3/4"	BSH1570	4 5/8"	BSH15463	4 1/8"	BSH25105	-	-

Back-Up Spanners for Torque Wrenches

▼ BUS03 Back-Up Spanner (safety cable not shown)



- Hands free solution – improves operator safety
- Eliminates the need for flogging spanners
- Speeds up the bolting process
- Includes safety cable with quick-connect carabiner's, stainless steel tethers and secure Allen-key fixings
- Won't lock on during operations
- Lightweight, spark-free and non-impact for improved safety and ease of use
- Two hexagon sizes in one tool, so fewer tools to carry.

▼ SELECTION CHART BACK-UP SPANNERS

Hexagon Sizes (A/F)		Model Number	Dimensions (mm)				Weight (kg)
S1 to S2 (mm)	S1 to S2 (inch)		A	B	C	D	
27 - 32	1 ¹ / ₁₆ - 1 ¹ / ₄ "	BUS01	51	98	15	M8	0,3
36 - 41	1 ⁷ / ₁₆ - 1 ⁵ / ₈ "	BUS02	62	119	15	M8	0,4
46 - 50	1 ¹³ / ₁₆ - 2"	BUS03	75	141	20	M8	0,6
55 - 60	2 ³ / ₁₆ - 2 ³ / ₄ "	BUS04	89	166	20	M12	0,8
65 - 70	2 ⁹ / ₁₆ - 2 ³ / ₄ "	BUS05	100	190	25	M16	1,0
75 - 80	2 ¹⁵ / ₁₆ - 3 ¹ / ₈ "	BUS06	112	213	25	M16	1,3
-	3 ¹ / ₂ - 3 ⁷ / ₈ "	BUS07	135	257	30	M20	2,2
-	4 ¹ / ₄ - 4 ⁵ / ₈ "	BUS08	163	310	30	M20	3,3
85 - 90	-	BUS09	126	242	25	M16	1,7
95 - 100	3 ³ / ₄ - 3 ¹⁵ / ₁₆ "	BUS10	138	266	30	M20	2,3
105 - 110	4 ¹ / ₈ - 4 ¹⁵ / ₁₆ "	BUS11	153	297	30	M20	3,1
115 - 120	-	BUS12	165	320	30	M20	3,5

BUS Series

Hexagon Sizes (A/F):
27 - 120 mm

Hexagon Sizes (A/F):
1¹/₁₆ - 4¹⁵/₁₆ inch



Back-Up Spanners

Hands free operation of a hydraulic torque wrench improves the safety of the operator significantly.

Enerpac Back-Up Spanners are a hands free tool that eliminates the need to use a flogging spanner as a backing tool.

The Back-Up Spanners have been specifically designed to prevent them from locking onto the nut during bolt torquing operations.

They fit easily onto the back nut and prevent it from turning during make up or break out of bolted joints.

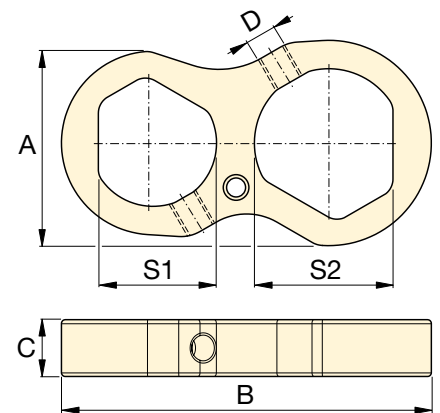

▼ Enerpac Back-Up Spanners to be used to stop the back nut from turning during make up or break out.



▼ Shown: Two models of STTLS 31055 Safe T™ Torque Lock



Hands-free torque wrench system



Safe T™ Torque Lock

The Safe T™ Torque Lock is suitable for all bolted applications from 190 Nm to 15.000 Nm using a heavy duty impact socket.

The patented mechanical locking system creates a hands-free torque wrench solution suitable for Enerpac only square drive tools.

Suitable for:

S-Series	RSQ-Series
S3000X	RSQ3000
S6000X	RSQ5000
S11000X	RSQ11000

Safety – Safe T™ Torque Lock

- Transforming Enerpac S-Series & RSQ-Series wrenches into a dedicated hands-free tool
- Improves operator safety during bolting operations by minimizing exposure to pinch points and high pressure hydraulic connections
- Grips securely to the application in any orientation, including inverted positions
- Minimizes drop hazards of falling tools
- Reduces operator fatigue on overreaching or awkward positioning of the tool.

Simplicity

- With one twist of the locking collar the Safe T™ Torque Lock grips onto the nut, firmly holding the full tool weight in place
- Assembles onto the torque wrench with one push of the square drive quick release button for tightening or loosening
- Locking feature reduces the number of tool lifts dramatically.

Versatility

- Suitable for both S-Series & RSL-Series square drive wrenches
- Simple twist & lock mechanism is user friendly, easy to operate
- No additional loose components like reaction washers are needed.



▲ Hands-free torque wrench system: STLLS-model with S-Series torque wrench. The square drive of the wrench can easily be exchanged by the Safe T™ Torque Lock model.



Back-Up Spanners, BUS-Series

Hands free tool to be used to stop the back nut from turning during make up or break out.



Common Torque Lock Applications:

- Oil & Gas flanges
- Tower Crane installation
- Machine installation/assembly (Mining),
- Wind Tower installation etc.

Industries

- Oil & Gas, Petrochemical
- Wind Power Generation
- Mining
- Marine
- Manufacturing
- Rail and more

STTL Series



Hexagon Range (A/F):

46 - 75 mm

Hexagon Range (A/F):

1 13/16 - 3 1/8 inch

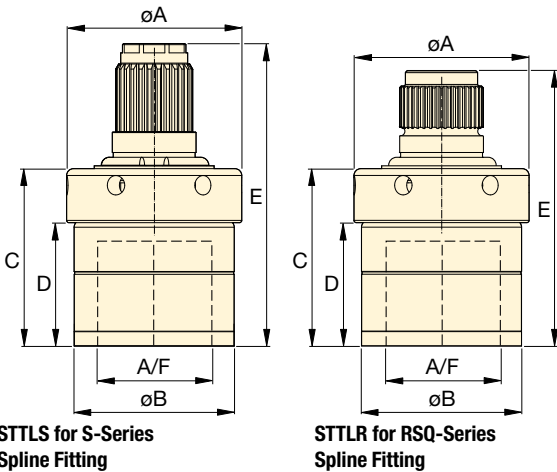

IMPORTANT:
Safe T™ Torque Lock
not suitable for use
on PTFE coated nuts.



Bolting Integrity Software

Enerpac Bolting Integrity Software Solutions play a key role in implementing and managing an Integrity Program for bolted connections. The software offers Tool selection, Bolt Load calculations and Tool pressure settings, as well as, a combined Application Data Sheet and Joint Completion Report. Custom Joint information can also be entered.

Page: **142**

Hexagon Sizes A/F		For use with torque wrench model	Safe T™ Torque Lock Model Number		Dimensions (inch)					⚖️ (lbs)	Dimensions (mm)					⚖️ (kg)
(inch)	(mm)		For S-Series Spline Fitting	For RSQ-Series Spline Fitting	A	B	C	D	E		A	B	C	D	E	
1 13/16	46	S3000X	STTLS31046	-	3.0	2.8	3.1	2.1	5.2	4.4	77	71	78	54	133	2.0
		RSQ3000	-	STTLR31046					4.8	4.2					121	1.9
2	50	S3000X	STTLS31550	-	3.5	3.2	3.1	2.1	5.2	5.7	89	82	78	54	133	2.6
		RSQ3000	-	STTLR31550					4.8	5.7					123	2.6
2 3/16	55	S3000X	STTLS31055	-	3.7	3.4	3.3	2.3	5.4	6.6	93	86	83	58	138	3.0
		RSQ3000	-	STTLR31055					5.1	6.4					130	2.9
2 3/8	-	RSQ3000	-	STTLR315238	3.9	3.6	3.6	2.6	5.4	7.7	99	92	91	67	136	3.5
2	50	RSQ5000	-	STTLR51550	3.5	3.2	3.1	2.1	5.2	5.9	89	82	78	54	132	2.7
		S6000X	STTLS61560M	-					5.9	8.2					150	3.7
-	60	RSQ5000	-	STTLR51560M	3.9	3.6	3.4	2.5	5.7	8.2	99	92	86	62	145	3.7
		S6000X	STTLS615238	-					6.0	8.4					154	3.8
2 3/8	-	RSQ5000	-	STTLR515238	3.9	3.6	3.6	2.6	5.9	8.4	99	92	91	67	150	3.8
		S6000X	STTLS61565	-					6.8	11.7					172	5.3
2 9/16	65	RSQ5000	-	STTLR51565	4.2	3.9	4.2	2.9	6.6	11.9	107	100	108	74	168	5.4
		S6000X	STTLS61570	-					6.8	13.0					173	5.9
2 3/4	70	RSQ5000	-	STTLR51570	4.5	4.2	4.3	3.0	6.7	13.2	114	107	109	76	169	6.0
		S6000X	STTLS61575	-					7.0	12.3					177	5.6
2 15/16	75	RSQ5000	-	STTLR51575	4.4	4.1	4.4	3.1	6.9	13.2	112	105	113	80	173	5.8
		S6000X	STTLS111560M	-					6.6	9.3					167	4.2
-	60	RSQ11000	-	STTLR111560M	3.9	3.6	3.4	2.5	6.1	9.3	99	92	86	62	156	4.2
		S11000X	STTLS111565	-					7.5	12.8					189	5.8
2 9/16	65	RSQ11000	-	STTLR111565	4.2	3.9	4.2	2.9	7.0	12.8	107	100	107	74	178	5.8
		S11000X	STTLS111570	-					7.5	14.1					191	6.4
2 3/4	70	RSQ11000	-	STTLR111570	4.5	4.2	4.3	3.0	7.1	14.3	114	107	109	76	181	6.5
		S11000X	STTLS111575	-					7.7	13.2					195	6.0
2 15/16	75	RSQ11000	-	STTLR111575	4.4	4.1	4.4	3.1	7.2	13.2	112	105	113	80	183	6.0
		S11000X	STTLS1115318	-					7.8	16.1					197	7.3
3 1/8	-	RSQ11000	-	STTLR1115318	4.8	4.5	4.5	3.2	7.3	16.3	122	115	115	81	185	7.4
		S11000X	STTLS1115318	-					7.8	16.1					197	7.3

Double-Acting Hydraulic Hexagon Torque Wrenches, X-Edition

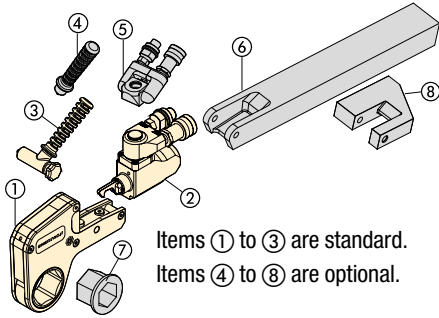

- ① Hexagon Cassette (pages 14-21)
- ② Drive Unit (page 13)
- ③ Angled Positioning Handle (page 12)
- ④ Straight Positioning Handle (page 12)
- ⑤ Pro Series Swivel (page 24)
- ⑥ Extended Reaction Arm (page 24)
- ⑦ Reducer Insert (pages 14-21)
- ⑧ Reaction Paddle (page 24)

Items ① to ③ are standard.
Items ④ to ⑧ are optional.

W Series X-Edition



Nominal Torque at 690 bar:

47.454 Nm

Hexagon Range:

30 - 155 mm / 1 1/16 - 6 1/8"

Nose Radius:

31 - 115 mm

Maximum Operating Pressure:

690 bar

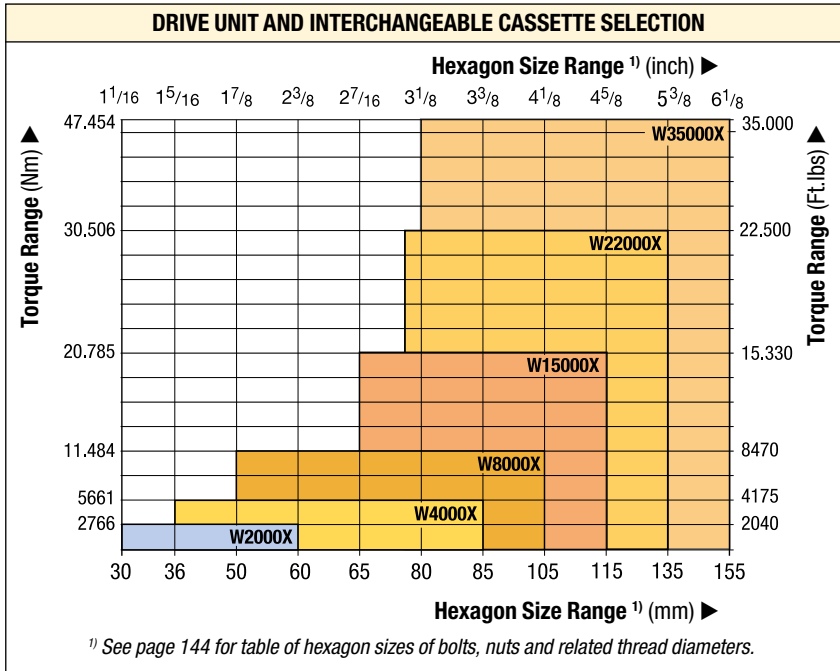

Torque Pump Selection Matrix

For optimum speed and performance see the torque wrench and pump matrix.

Page: **55**

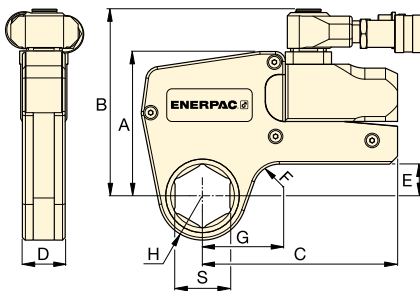

These rigid steel wrenches with low profile interchangeable hexagon cassettes guarantee durability and maximum versatility in bolting applications. ▶



▼ SELECTION CHART

Hexagon Range *		Nominal Torque at 690 bar		Drive Unit Model Number **	Minimum Torque		Dimensions (mm) (see pages 14-21 for dimensions G, H and S)						Weight (drive unit without hexagon cassette) (kg)
(mm)	(inch)	(Nm)	(Ft.lbs)		(Nm)	(Ft.lbs)	A	B	C	D	E	F	
30 - 60	1 1/16 - 2 3/8	2766	2040	W2000X	276	204	109	141	148	32	24	20	1,4
36 - 85	1 5/16 - 3 3/8	5661	4175	W4000X	566	417	136	167	178	41	33	20	2,0
50 - 105	1 7/8 - 4 1/8	11.484	8470	W8000X	1148	847	172	205	208	53	42	25	3,0
65 - 115	2 7/16 - 4 5/8	20.785	15.330	W15000X	2078	1533	207	240	253	63	50	20	5,0
75 - 135	2 15/16 - 5 3/8	30.506	22.500	W22000X	3050	2250	227	266	297	77	48	35	7,7
80 - 155	3 1/8 - 6 1/8	47.454	35.000	W35000X	4745	3500	268	301	345	91	69-73	50	11,4

* With in-line reaction foot.

** To order a W-series wrench fitted with the TSP swivel, suffix the model number with "-P". Example: **W2000PX**.

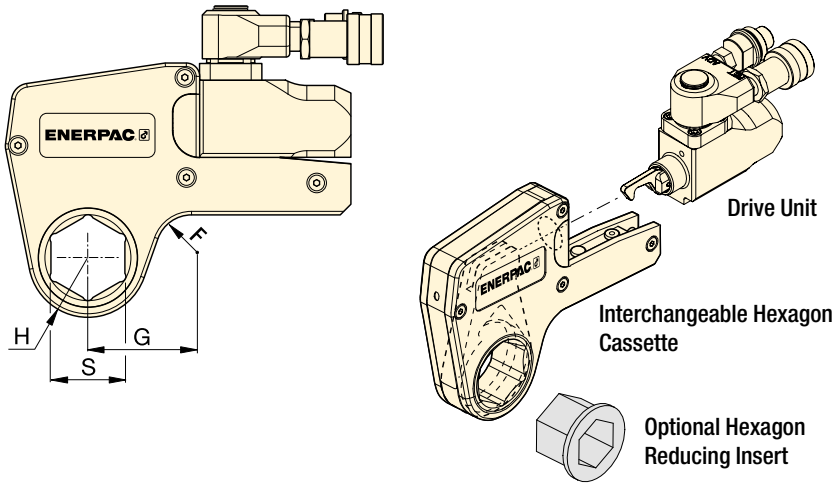

W Series X-Edition



Nominal Torque at 690 bar:

2766 Nm

Hexagon Range:

1¹/₁₆ - 2³/₈ inch

Maximum Operating Pressure:

690 bar



Metric Sizes

For metric sizes of hexagon cassettes and reducer inserts see:

Page: **20**



Back-Up Spanners

Hands free tool to be used to stop the back nut from turning during make up or break out.

Page: **11**

▼ SELECTION CHART

Drive Unit Model Number	Hexagon Size ¹⁾	Nose Radius	Dim.	Model Number	Weight (kg)	Hexagon Reducer		Hexagon Reducer		Hexagon Reducer	
						Hexagon Reducer (inch)	Model Number	Hexagon Reducer (inch)	Model Number	Hexagon Reducer (inch)	Model Number
W2000X	1 ¹ / ₁₆	31,0	53,7	W2101X	2,1	-	-	-	-	-	-
	1 ¹ / ₈	31,0	53,7	W2102X	2,1	-	-	-	-	-	-
	1 ³ / ₁₆	31,0	53,7	W2103X	2,1	-	-	-	-	-	-
	1 ¹ / ₄	31,0	53,7	W2104X	2,1	-	-	-	-	-	-
	1 ⁵ / ₁₆	31,0	53,7	W2105X	2,1	-	-	-	-	-	-
	1 ³ / ₈	31,0	53,7	W2106X	2,1	-	-	-	-	-	-
	1 ⁷ / ₁₆	31,0	53,7	W2107X	2,1	1 ⁷ / ₁₆ - 1 ¹ / ₈	W2107R102	-	-	-	-
	1 ¹ / ₂	33,5	58,2	W2108X	2,2	-	-	-	-	-	-
	1 ⁹ / ₁₆	33,5	58,2	W2109X	2,2	-	-	-	-	-	-
	1 ⁵ / ₈	33,5	58,2	W2110X	2,2	1 ⁵ / ₈ - 1 ¹ / ₄	W2110R104	1 ⁵ / ₈ - 1 ³ / ₁₆	W2110R103	-	-
	1 ¹¹ / ₁₆	36,5	60,5	W2111X	2,2	-	-	-	-	-	-
	1 ³ / ₄	36,5	60,5	W2112X	2,2	-	-	-	-	-	-
	1 ¹³ / ₁₆	36,5	60,5	W2113X	2,2	1 ¹³ / ₁₆ - 1 ⁷ / ₁₆	W2113R107	1 ¹³ / ₁₆ - 1 ¹ / ₄	W2113R104	-	-
	1 ⁷ / ₈	39,0	63,1	W2114X	2,2	-	-	-	-	-	-
	1 ¹⁵ / ₁₆	39,0	63,1	W2115X	2,2	-	-	-	-	-	-
	2	39,0	63,1	W2200X	2,2	2 - 1 ⁵ / ₈	W2200R110	2 - 1 ⁷ / ₁₆	W2200R107	-	-
	2 ¹ / ₁₆	41,8	68,6	W2201X	2,3	-	-	-	-	-	-
	2 ¹ / ₈	41,8	68,6	W2202X	2,3	-	-	-	-	-	-
	2 ³ / ₁₆	41,8	68,6	W2203X	2,3	2 ³ / ₁₆ - 1 ¹³ / ₁₆	W2203R113	2 ³ / ₁₆ - 1 ⁵ / ₈	W2203R110	2 ³ / ₁₆ - 1 ⁷ / ₁₆	W2203R107
	2 ¹ / ₄	44,5	64,8	W2204X	2,2	-	-	-	-	-	-
2 ⁵ / ₁₆	44,5	64,8	W2205X	2,2	-	-	-	-	-	-	
2 ³ / ₈	44,5	64,8	W2206X	2,2	2 ³ / ₈ - 2	W2206R200	2 ³ / ₈ - 1 ⁷ / ₈	W2206R114	2 ³ / ₈ - 1 ¹³ / ₁₆	W2206R113	
-	-	-	-	-	-	2 ³ / ₈ - 1 ¹ / ₂	W2206R108	2 ³ / ₈ - 1 ⁷ / ₁₆	W2206R107	2 ³ / ₈ - 1 ⁵ / ₁₆	W2206R110

¹⁾ See page 144 for table of hexagon sizes of bolts, nuts and related thread diameters.

W4000X-Series, Inch-Cassettes & Reducer Inserts

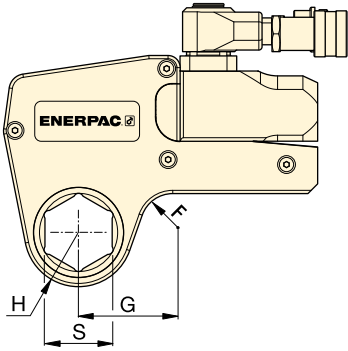

Nominal Torque at 690 bar:

5661 Nm

Hexagon Range:

1⁵/₁₆ - 3³/₈ inch

Maximum Operating Pressure:

690 bar

W
Series
X-Edition



Drive Unit Model Number	Hexagon Size ¹⁾	Nose Radius	Dim.	Model Number	Weight (kg)	Hexagon Reducer		Hexagon Reducer		Hexagon Reducer	
						Hexagon Reducer (inch)	Model Number	Hexagon Reducer (inch)	Model Number	Hexagon Reducer (inch)	Model Number
W4000X	1 ⁵ / ₁₆	37,0	61,0	W4105X	3,7	-	-	-	-	-	-
	1 ³ / ₈	37,0	61,0	W4106X	3,7	-	-	-	-	-	-
	1 ⁷ / ₁₆	37,0	61,0	W4107X	3,7	-	-	-	-	-	-
	1 1/2	37,0	61,0	W4108X	3,7	-	-	-	-	-	-
	1 ⁹ / ₁₆	37,0	61,0	W4109X	3,7	-	-	-	-	-	-
	1 ⁵ / ₈	37,0	61,0	W4110X	3,7	-	-	-	-	-	-
	1 ¹¹ / ₁₆	39,5	64,0	W4111X	3,8	-	-	-	-	-	-
	1 ³ / ₄	39,5	64,0	W4112X	3,8	-	-	-	-	-	-
	1 ¹³ / ₁₆	39,5	64,0	W4113X	3,8	-	-	-	-	-	-
	1 ⁷ / ₈	41,5	66,7	W4114X	3,9	-	-	-	-	-	-
	1 ¹⁵ / ₁₆	41,5	66,7	W4115X	3,9	-	-	-	-	-	-
	2	41,5	66,7	W4200X	3,9	2 - 1 ⁷ / ₁₆	W4200R107	-	-	-	-
	2 ¹ / ₁₆	44,0	73,4	W4201X	4,0	-	-	-	-	-	-
	2 ¹ / ₈	44,0	73,4	W4202X	4,0	-	-	-	-	-	-
	2 ³ / ₁₆	44,0	73,4	W4203X	4,0	2 ³ / ₁₆ - 1 ⁵ / ₈	W4203R110	2 ³ / ₁₆ - 1 ⁷ / ₁₆	W4203R107	2 ³ / ₁₆ - 1 ¹ / ₄	W4203R104
	2 ¹ / ₄	46,5	70,6	W4204X	4,1	-	-	-	-	-	-
	2 ⁵ / ₁₆	46,5	70,6	W4205X	4,1	-	-	-	-	-	-
	2 ³ / ₈	46,5	70,6	W4206X	4,1	2 ³ / ₈ - 2	W4206R200	2 ³ / ₈ - 1 ¹³ / ₁₆	W4206R113	2 ³ / ₈ - 1 ⁷ / ₁₆	W4206R107
	-	-	-	-	-	2 ³ / ₈ - 1 ³ / ₈	W4206R106	-	-	-	-
	2 ⁷ / ₁₆	49,5	76,2	W4207X	4,1	2 ⁷ / ₁₆ - 2	W4207R200	-	-	-	-
	2 1/2	49,5	76,2	W4208X	4,1	2 ¹ / ₂ - 2	W4208R200	2 ¹ / ₂ - 1 ⁷ / ₁₆	W4208R113	2 ¹ / ₂ - 2 ¹ / ₁₆	W4208R201
	2 ⁹ / ₁₆	49,5	76,2	W4209X	4,1	2 ⁹ / ₁₆ - 2 ³ / ₁₆	W4209R203	2 ⁹ / ₁₆ - 2 ¹ / ₈	W4209R202	2 ⁹ / ₁₆ - 2 ¹ / ₁₆	W4209R201
	-	-	-	-	-	2 ⁹ / ₁₆ - 2	W4209R200	2 ⁹ / ₁₆ - 1 ¹³ / ₁₆	W4209R113	-	-
	2 ⁵ / ₈	52,5	78,3	W4210X	4,2	-	-	-	-	-	-
	2 ¹¹ / ₁₆	52,5	78,3	W4211X	4,2	-	-	-	-	-	-
	2 ³ / ₄	52,5	78,3	W4212X	4,2	2 ³ / ₄ - 2 ³ / ₈	W4212R206	2 ³ / ₄ - 2 ³ / ₁₆	W4212R203	2 ³ / ₄ - 2 ¹ / ₈	W4212R202
	2 ¹³ / ₁₆	55,3	81,6	W4213X	4,3	-	-	-	-	-	-
	2 ⁷ / ₈	55,3	81,6	W4214X	4,3	-	-	-	-	-	-
	2 ¹⁵ / ₁₆	55,3	81,6	W4215X	4,3	2 ¹⁵ / ₁₆ - 2 ⁹ / ₁₆	W4215R209	2 ¹⁵ / ₁₆ - 2 ³ / ₈	W4215R206	2 ¹⁵ / ₁₆ - 2 ³ / ₁₆	W4215R203
	-	-	-	-	-	2 ¹⁵ / ₁₆ - 2	W4215R200	-	-	-	-
	3	58,5	83,5	W4300X	4,4	3 - 2 ⁹ / ₁₆	W4300R203	-	-	-	-
	3 ¹ / ₁₆	58,5	83,5	W4301X	4,4	-	-	-	-	-	-
	3 ¹ / ₈	58,5	83,5	W4302X	4,4	3 ¹ / ₈ - 2 ³ / ₄	W4302R212	3 ¹ / ₈ - 2 ⁹ / ₁₆	W4302R209	3 ¹ / ₈ - 2 ³ / ₈	W4302R206
	-	-	-	-	-	3 ¹ / ₈ - 2 ⁵ / ₁₆	W4302R205	3 ¹ / ₈ - 2 ¹ / ₄	W4302R204	3 ¹ / ₈ - 2 ³ / ₁₆	W4302R203
	-	-	-	-	-	3 ¹ / ₈ - 2 ³ / ₁₆	W4302R203	3 ¹ / ₈ - 2 ¹ / ₈	W4302R202	3 ¹ / ₈ - 2	W4302R200
	3 ³ / ₁₆	62,0	85,5	W4303X	4,5	-	-	-	-	-	-
3 ¹ / ₄	62,0	85,5	W4304X	4,5	-	-	-	-	-	-	
3 ⁵ / ₁₆	62,0	85,5	W4305X	4,5	-	-	-	-	-	-	
3 ³ / ₈	62,0	85,5	W4306X	4,5	-	-	-	-	-	-	

¹⁾ See page 144 for table of hexagon sizes of bolts, nuts and related thread diameters.

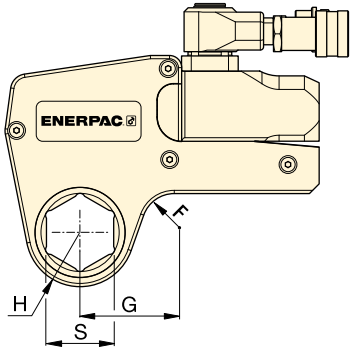

Nominal Torque at 690 bar:

11.484 Nm

Hexagon Range:

1 7/8 - 4 1/8 inch

Maximum Operating Pressure:

690 bar

W
Series
X-Edition



▼ SELECTION CHART

Drive Unit Model Number	Hexagon Size ¹⁾	Nose Radius	Dim.	Model Number	Weight (kg)	Hexagon Reducer		Hexagon Reducer		Hexagon Reducer	
						Hexagon Reducer (inch)	Model Number	Hexagon Reducer (inch)	Model Number	Hexagon Reducer (inch)	Model Number
W8000X	S (inch)	H (mm)	G (mm)								
	1 7/8	45,0	78,2	W8114X	8,1	-	-	-	-	-	-
	1 15/16	45,0	78,2	W8115X	8,1	-	-	-	-	-	-
	2	45,0	78,2	W8200X	8,1	-	-	-	-	-	-
	2 1/16	48,0	80,0	W8201X	8,1	-	-	-	-	-	-
	2 1/8	48,0	80,0	W8202X	8,1	-	-	-	-	-	-
	2 3/16	48,0	80,0	W8203X	8,1	-	-	-	-	-	-
	2 1/4	51,0	82,5	W8204X	8,1	-	-	-	-	-	-
	2 5/16	51,0	82,5	W8205X	8,1	-	-	-	-	-	-
	2 3/8	51,0	82,5	W8206X	8,1	-	-	-	-	-	-
	2 7/16	52,5	85,9	W8207X	8,1	-	-	-	-	-	-
	2 1/2	52,5	85,9	W8208X	8,1	-	-	-	-	-	-
	2 9/16	52,5	85,9	W8209X	8,1	2 9/16 - 2	W8209R200	-	-	-	-
	2 5/8	56,0	84,8	W8210X	8,1	-	-	-	-	-	-
	2 11/16	56,0	84,8	W8211X	7,9	-	-	-	-	-	-
	2 3/4	56,0	84,8	W8212X	7,9	2 3/4 - 2 3/16	W8212R203	-	-	-	-
	2 13/16	58,0	85,0	W8213X	7,9	-	-	-	-	-	-
	2 7/8	58,0	85,0	W8214X	7,9	-	-	-	-	-	-
	2 15/16	58,0	85,0	W8215X	7,9	2 15/16 - 2 3/8	W8215R206	2 15/16 - 2 3/16	W8215R203	-	-
	3	60,5	89,5	W8300X	8,0	-	-	-	-	-	-
	3 1/16	60,5	89,5	W8301X	8,0	-	-	-	-	-	-
	3 1/8	60,5	89,5	W8302X	8,0	3 1/8 - 2 9/16	W8302R209	3 1/8 - 2 3/8	W8302R206	3 1/8 - 2 3/16	W8302R203
	-	-	-	-	-	3 1/8 - 2	W8302R200	-	-	-	-
	3 3/16	66,0	92,2	W8303X	8,2	-	-	-	-	-	-
	3 1/4	66,0	92,2	W8304X	8,2	-	-	-	-	-	-
	3 5/16	66,0	92,2	W8305X	8,2	-	-	-	-	-	-
	3 3/8	66,0	92,2	W8306X	8,2	-	-	-	-	-	-
	3 7/16	66,0	92,2	W83071X	8,2	-	-	-	-	-	-
	3 1/2	66,0	92,2	W8308X	8,2	3 1/2 - 3	W8308R300	3 1/2 - 2 15/16	W8308R215	3 1/2 - 2 3/4	W8308R212
	3 9/16	74,0	102,9	W8309X	8,8	-	-	-	-	-	-
	3 5/8	74,0	102,9	W8310X	8,8	-	-	-	-	-	-
	3 11/16	74,0	102,9	W8311X	8,8	-	-	-	-	-	-
3 3/4	74,0	102,9	W8312X	8,8	3 3/4 - 3 1/8	W8312R302	3 3/4 - 2 15/16	W8312R215	3 3/4 - 2 3/4	W8312R212	
3 13/16	74,0	102,9	W8313X	8,8	-	-	-	-	-	-	
3 7/8	74,0	102,9	W8314X	8,8	3 7/8 - 3 1/8	W8314R302	3 7/8 - 2 15/16	W8314R215	-	-	
3 15/16	79,5	110,0	W8315X	9,3	-	-	-	-	-	-	
4	79,5	110,0	W8400X	9,3	-	-	-	-	-	-	
4 1/16	79,5	110,0	W84011X	9,3	-	-	-	-	-	-	
4 1/8	79,5	110,0	W8402X	9,3	-	-	-	-	-	-	

¹⁾ See page 144 for table of hexagon sizes of bolts, nuts and related thread diameters.

W15000X-Series, Inch-Cassettes & Reducer Inserts

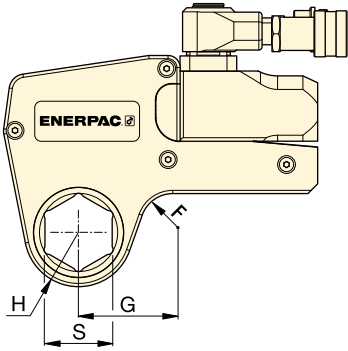

Nominal Torque at 690 bar:

20.785 Nm

Hexagon Range:

2¹/₈ - 4⁵/₈ inch

Maximum Operating Pressure:

690 bar

W
Series
X-Edition



▼ SELECTION CHART

Drive Unit Model Number	Hexagon Size ¹⁾	Nose Radius	Dim.	Model Number	Weight (kg)	Hexagon Reducer		Hexagon Reducer		Hexagon Reducer	
						Hexagon Reducer (inch)	Model Number	Hexagon Reducer (inch)	Model Number	Hexagon Reducer (inch)	Model Number
W15000X	2 ⁷ / ₁₆	59,0	88,6	W15207X	13,6	-	-	-	-	-	-
	2 ¹ / ₂	59,0	88,6	W15208X	13,6	-	-	-	-	-	-
	2 ⁹ / ₁₆	59,0	88,6	W15209X	13,6	-	-	-	-	-	-
	2 ⁵ / ₈	59,0	88,6	W15210X	13,6	-	-	-	-	-	-
	2 ¹¹ / ₁₆	59,0	88,6	W15211X	13,6	-	-	-	-	-	-
	2 ³ / ₄	59,0	88,6	W15212X	13,6	-	-	-	-	-	-
	2 ¹³ / ₁₆	62,0	90,5	W15213X	13,7	-	-	-	-	-	-
	2 ⁷ / ₈	62,0	90,5	W15214X	13,7	-	-	-	-	-	-
	2 ¹⁵ / ₁₆	62,0	90,5	W15215X	13,7	-	-	-	-	-	-
	3	64,5	92,9	W15300X	13,8	3 - 2 ¹ / ₈	W15300R202	-	-	-	-
	3 ¹ / ₁₆	64,5	92,9	W15301X	13,8	-	-	-	-	-	-
	3 ¹ / ₈	64,5	92,9	W15302X	13,8	3 ¹ / ₈ - 2 ⁹ / ₁₆	W15302R209	-	-	-	-
	3 ³ / ₁₆	69,5	96,6	W15303X	14,1	-	-	-	-	-	-
	3 ¹ / ₄	69,5	96,6	W15304X	14,1	-	-	-	-	-	-
	3 ⁵ / ₁₆	69,5	96,6	W15305X	14,1	-	-	-	-	-	-
	3 ³ / ₈	69,5	96,6	W15306X	14,1	-	-	-	-	-	-
	3 ⁷ / ₁₆	69,5	96,6	W15307IX	14,1	-	-	-	-	-	-
	3 ¹ / ₂	69,5	96,6	W15308X	14,1	3 ¹ / ₂ - 2 ¹⁵ / ₁₆	W15308R215	3 ¹ / ₂ - 2 ³ / ₄	W15308R212	-	-
	3 ⁹ / ₁₆	75,0	101,8	W15309X	14,6	-	-	-	-	-	-
	3 ⁵ / ₈	75,0	101,8	W15310X	14,6	-	-	-	-	-	-
	3 ¹¹ / ₁₆	75,0	101,8	W15311X	14,6	-	-	-	-	-	-
	3 ³ / ₄	75,0	101,8	W15312X	14,6	3 ³ / ₄ - 3 ¹ / ₈	W15312R302	3 ³ / ₄ - 2 ¹⁵ / ₁₆	W15312R215	-	-
	3 ¹³ / ₁₆	75,0	101,8	W15313X	14,5	-	-	-	-	-	-
	3 ⁷ / ₈	75,0	101,8	W15314X	14,5	3 ⁷ / ₈ - 3 ¹ / ₈	W15314R302	3 ⁷ / ₈ - 2 ¹⁵ / ₁₆	W15314R215	-	-
	3 ¹⁵ / ₁₆	80,5	103,1	W15315X	14,8	-	-	-	-	-	-
	4	80,5	103,1	W15400X	14,8	-	-	-	-	-	-
	4 ¹ / ₁₆	80,5	103,1	W15401IX	14,8	-	-	-	-	-	-
	4 ¹ / ₈	80,5	103,1	W15402X	14,8	4 ¹ / ₈ - 3 ¹ / ₂	W15402R308	4 ¹ / ₈ - 3 ⁵ / ₁₆	W15402R305	4 ¹ / ₈ - 3 ¹ / ₄	W15402R304
	4 ³ / ₁₆	80,5	103,1	W15403IX	14,8	-	-	-	-	-	-
	4 ¹ / ₄	80,5	103,1	W15404X	14,8	4 ¹ / ₄ - 3 ¹ / ₂	W15404R308	4 ¹ / ₄ - 3 ¹ / ₈	W15404R302	-	-
	4 ⁵ / ₁₆	87,5	114,8	W15405X	15,1	-	-	-	-	-	-
	4 ³ / ₈	87,5	114,8	W15406X	15,1	-	-	-	-	-	-
4 ⁷ / ₁₆	87,5	114,8	W15407X	15,1	-	-	-	-	-	-	
4 ¹ / ₂	87,5	114,8	W15408IX	15,1	-	-	-	-	-	-	
4 ⁹ / ₁₆	87,5	114,8	W15409IX	15,1	-	-	-	-	-	-	
4 ⁵ / ₈	87,5	114,8	W15410IX	15,1	4 ⁵ / ₈ - 3 ¹⁵ / ₁₆	W15410R315	4 ⁵ / ₈ - 3 ⁷ / ₈	W15410R314	4 ⁵ / ₈ - 3 ³ / ₄	W15410R312	
-	-	-	-	-	-	4 ⁵ / ₈ - 3 ¹ / ₂	W15410R308	-	-	-	
-	-	-	-	-	-	-	-	-	-	-	

¹⁾ See page 144 for table of hexagon sizes of bolts, nuts and related thread diameters.

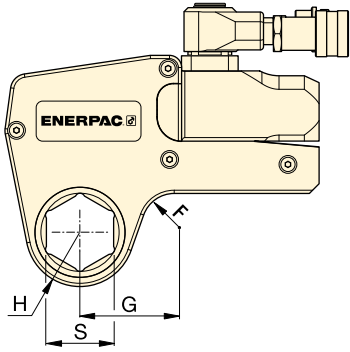

Nominal Torque at 690 bar:

30.506 Nm

Hexagon Range:

2¹⁵/₁₆ - 5³/₈ inch

Maximum Operating Pressure:

690 bar

W
Series
X-Edition



▼ SELECTION CHART

Drive Unit Model Number	Hexagon Size ¹⁾ S (inch)	Nose Radius H (mm)	G (mm)	Model Nr. Cassette	Weight (kg)	Hexagon Reducer		Hexagon Reducer		Hexagon Reducer	
						Hexagon Reducer (inch)	Model Number Reducer	Hexagon Reducer (inch)	Model Number Reducer	Hexagon Reducer (inch)	Model Number Reducer
W22000X	2 ¹⁵ / ₁₆	67,0	102,1	W22215X	22,1	-	-	-	-	-	-
	3	67,0	102,1	W22300X	22,0	-	-	-	-	-	-
	3 ¹ / ₁₆	67,0	102,1	W22301X	21,9	-	-	-	-	-	-
	3 ¹ / ₈	67,0	102,1	W22302X	21,6	3 ¹ / ₈ - 2 ³ / ₈	W22302R206	3 ¹ / ₈ - 2 ³ / ₁₆	W22302R203	-	-
	3 ³ / ₁₆	72,4	107,4	W22303X	22,9	-	-	-	-	-	-
	3 ¹ / ₄	72,4	107,4	W22304X	22,8	-	-	-	-	-	-
	3 ⁵ / ₁₆	72,4	107,4	W22305X	22,6	-	-	-	-	-	-
	3 ³ / ₈	72,4	107,4	W22306X	22,5	-	-	-	-	-	-
	3 ⁷ / ₁₆	72,4	107,4	W22307IX	22,8	-	-	-	-	-	-
	3 ¹ / ₂	72,4	107,4	W22308X	22,2	3 ¹ / ₂ - 2 ³ / ₄	W22308R212	3 ¹ / ₂ - 2 ⁹ / ₁₆	W22308R209	3 ¹ / ₂ - 2 ³ / ₈	W22308R206
	3 ⁹ / ₁₆	77,9	113,0	W22309X	23,4	-	-	-	-	-	-
	3 ⁵ / ₈	77,9	113,0	W22310X	23,3	-	-	-	-	-	-
	3 ¹¹ / ₁₆	77,9	113,0	W22311X	23,1	-	-	-	-	-	-
	3 ³ / ₄	77,9	113,0	W22312X	22,9	3 ³ / ₄ - 2 ¹⁵ / ₁₆	W22312R215	-	-	-	-
	3 ¹³ / ₁₆	77,9	113,0	W22313X	22,8	-	-	-	-	-	-
	3 ⁷ / ₈	77,9	113,0	W22314X	22,6	3 ⁷ / ₈ - 3 ¹ / ₈	W22314R302	3 ⁷ / ₈ - 2 ¹⁵ / ₁₆	W22314R215	3 ⁷ / ₈ - 2 ³ / ₄	W22314R212
	3 ¹⁵ / ₁₆	85,1	119,9	W22315X	24,3	-	-	-	-	-	-
	4	85,1	119,9	W22400X	24,1	-	-	-	-	-	-
	4 ¹ / ₁₆	85,1	119,9	W22401IX	24,0	-	-	-	-	-	-
	4 ¹ / ₈	85,1	119,9	W22402X	23,6	-	-	-	-	-	-
	4 ³ / ₁₆	85,1	119,9	W22403IX	23,6	-	-	-	-	-	-
	4 ¹ / ₄	85,1	119,9	W22404X	24,6	4 ¹ / ₄ - 3 ¹ / ₂	W22404R308	4 ¹ / ₄ - 3 ¹ / ₈	W22404R302	4 ¹ / ₄ - 2 ¹⁵ / ₁₆	W22404R215
	4 ⁵ / ₁₆	89,9	125,0	W22405X	24,6	-	-	-	-	-	-
	4 ³ / ₈	89,9	125,0	W22406X	24,5	-	-	-	-	-	-
	4 ⁷ / ₁₆	89,9	125,0	W22407X	24,3	-	-	-	-	-	-
	4 ¹ / ₂	89,9	125,0	W22408IX	24,1	-	-	-	-	-	-
	4 ⁹ / ₁₆	89,9	125,0	W22409IX	23,9	-	-	-	-	-	-
	4 ⁵ / ₈	89,9	125,0	W22410IX	23,6	4 ⁵ / ₈ - 3 ⁷ / ₈	W22410R314	4 ⁵ / ₈ - 3 ³ / ₄	W22410R312	4 ⁵ / ₈ - 3 ¹ / ₂	W22410R308
	4 ³ / ₄	95,0	130,0	W22412X	24,7	-	-	-	-	-	-
	4 ⁷ / ₈	95,0	130,0	W22414X	24,3	-	-	-	-	-	-
	5	95,0	130,0	W22500X	23,8	5 - 4 ¹ / ₄	W22500R404	5 - 4 ¹ / ₈	W22500R402	5 - 3 ⁷ / ₈	W22500R314
	5 ¹ / ₈	100,0	134,8	W22502X	25,0	-	-	-	-	-	-
5 ³ / ₁₆	100,0	134,8	W22503IX	24,8	-	-	-	-	-	-	
5 ¹ / ₄	100,0	134,8	W22504IX	24,5	-	-	-	-	-	-	
5 ³ / ₈	100,0	134,8	W22506X	23,9	5 ³ / ₈ - 4 ⁵ / ₈	W22506R410	5 ³ / ₈ - 4 ¹ / ₄	W22506R404	5 ³ / ₈ - 4 ¹ / ₈	W22506R402	
-	-	-	W22506X	23,9	5 ³ / ₈ - 3 ⁷ / ₈	W22506R314	-	-	-	-	

¹⁾ See page 144 for table of hexagon sizes of bolts, nuts and related thread diameters.

W35000X, Inch-Cassettes & Reducer Inserts

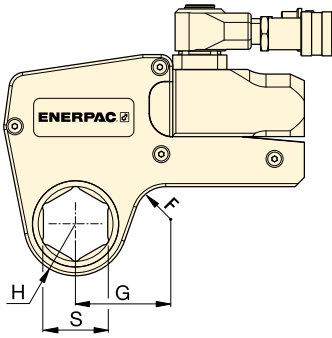

▼ SELECTION CHART

Drive Unit Model Number	Hexagon Size S (inch)	Nose Radius H (mm)	G (mm)	Model Nr. Cassette	Weight (kg)	Reducer	
						Hexagon Reducer (inch)	Model Number Reducer
W35000X	3 ¹ / ₈	76,0	126,8	W35302X	32,8	3 ¹ / ₈ - 2	W35302R200
	3 ³ / ₁₆	76,0	126,8	W35303X	32,7	-	-
	3 ¹ / ₄	76,0	126,8	W35304X	32,5	-	-
	3 ⁵ / ₁₆	76,0	126,8	W35305X	32,4	-	-
	3 ³ / ₈	76,0	126,8	W35306X	32,2	-	-
	3 ⁷ / ₁₆	76,0	126,8	W35307IX	32,0	-	-
	3 ¹ / ₂	76,0	126,8	W35308X	31,8	3 ¹ / ₂ - 2 ⁵ / ₁₆	W35308R205
	3 ⁹ / ₁₆	81,5	132,5	W35309X	32,4	-	-
	3 ⁵ / ₈	81,5	132,5	W35310X	33,3	-	-
	3 ¹¹ / ₁₆	81,5	132,5	W35311X	33,1	-	-
	3 ³ / ₄	81,5	132,5	W35312X	32,9	-	-
	3 ¹³ / ₁₆	81,5	132,5	W35313X	32,7	-	-
	3 ⁷ / ₈	81,5	132,5	W35314X	32,4	3 ⁷ / ₈ - 2 ¹¹ / ₁₆	W35314R211
	3 ¹⁵ / ₁₆	87,0	137,0	W35315X	34,1	3 ¹⁵ / ₁₆ - 2 ¹³ / ₁₆	W35315R213
	4	87,0	137,0	W35400X	33,9	-	-
	4 ¹ / ₁₆	87,0	137,0	W35401IX	33,7	-	-
	4 ¹ / ₈	87,0	137,0	W35402X	33,5	-	-
	4 ³ / ₁₆	87,0	137,0	W35403IX	33,3	-	-
	4 ¹ / ₄	87,0	137,0	W35404X	33,0	4 ¹ / ₄ - 3 ¹ / ₁₆	W35404R301
	4 ⁵ / ₁₆	93,0	143,0	W35405X	34,9	-	-
	4 ³ / ₈	93,0	143,0	W35406X	34,7	-	-
	4 ⁷ / ₁₆	93,0	143,0	W35407X	34,5	-	-
	4 ¹ / ₂	93,0	143,0	W35408IX	34,3	-	-
	4 ⁹ / ₁₆	93,0	143,0	W35409IX	34,1	-	-
	4 ⁵ / ₈	93,0	143,0	W35410IX	33,7	4 ⁵ / ₈ - 3 ⁵ / ₈	W35410R310
	4 ³ / ₄	98,5	148,5	W35412X	35,6	4 ³ / ₄ - 3 ³ / ₄	W35412R312
	4 ⁷ / ₈	98,5	148,5	W35414X	34,9	-	-
	5	98,5	148,5	W35500X	34,3	5 - 4	W35500R400
	5 ¹ / ₈	103,0	153,0	W35502X	35,8	5 ¹ / ₈ - 4 ¹ / ₈	W35502R402
	5 ³ / ₁₆	103,0	153,0	W35503IX	35,6	-	-
	5 ¹ / ₄	103,0	153,0	W35504IX	35,2	-	-
	5 ³ / ₈	103,0	153,0	W35506X	34,6	5 ³ / ₈ - 4 ⁵ / ₁₆	W35506R405
5 ¹ / ₂	108,5	158,5	W35508X	36,2	-	-	
5 ⁹ / ₁₆	108,5	158,5	W35509X	36,0	-	-	
5 ⁵ / ₈	108,5	158,5	W35510X	35,6	-	-	
5 ³ / ₄	108,5	164,0	W35512X	34,9	5 ³ / ₄ - 4 ³ / ₄	W35512R412	
5 ⁷ / ₈	114,0	164,0	W35514X	36,7	5 ⁷ / ₈ - 4 ⁷ / ₈	W35514R414	
6	114,0	164,0	W35600X	36,1	-	-	
6 ¹ / ₈	114,0	164,0	W35602X	35,3	6 ¹ / ₈ - 5 ¹ / ₈	W35602R502	

W Series X-Edition



Nominal Torque at 690 bar:

47.454 Nm

Hexagon Range:

3¹/₈ - 6¹/₈ inch

Maximum Operating Pressure:

690 bar



Back-Up Spanners

Hands free tool to be used to stop the back nut from turning during make up or break out.

Page: 11



Hexagon Bolt and Nut Sizes

See the table for hexagon sizes of bolts, nuts and related thread diameters.

Page: 144

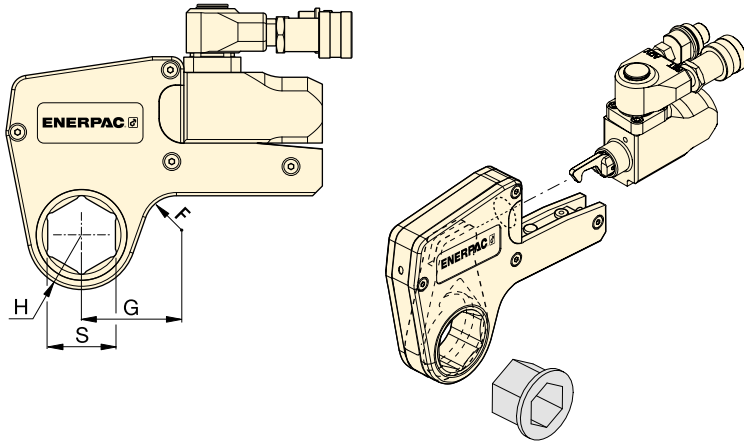

W Series X-Edition



Hexagon Range:

24 - 105 mm

Maximum Operating Pressure:

690 bar

▼ SELECTION CHART

Drive Unit Model Number	Hexagon Size ¹⁾ S (mm)	Nose Radius H (mm)	Dim. G (mm)	Model Nr. Cassette	Weight (kg)	Hexagon Reducer (mm)		Hexagon Reducer (mm)		Hexagon Reducer (mm)	
						Hexagon Reducer (mm)	Model Number Reducer	Hexagon Reducer (mm)	Model Number Reducer	Hexagon Reducer (mm)	Model Number Reducer
W2000X (2766 Nm)	30	31,0	54	W2103X	2,1	-	-	-	-	-	-
	32	31,0	54	W2104X	2,1	-	-	-	-	-	-
	36	31,0	54	W2107X	2,1	-	-	-	-	-	-
	38	33,5	58	W2108X	2,2	-	-	-	-	-	-
	41	33,5	58	W2110X	2,2	41 - 32	W2110R104	41 - 30	W2110R103	41 - 24	W2110R024M
	46	33,5	61	W2113X	2,2	46 - 36	W2113R107	46 - 32	W2113R104	-	-
	50	39,0	63	W2200X	2,2	50 - 41	W2200R110	50 - 36	W2200R107	-	-
	55	41,8	69	W2203X	2,3	55 - 46	W2203R113	55 - 41	W2203R110	55 - 36	W2203R107
	60	44,5	65	W2206X	2,2	60 - 50	W2206R200	60 - 46	W2206R113	60 - 41	W2206R110
	-	-	-	-	-	-	60 - 36	W2206R107	-	-	-
W4000X (5661 Nm)	36	37,0	61	W4107X	3,7	-	-	-	-	-	-
	41	37,0	61	W4110X	3,7	-	-	-	-	-	-
	46	39,5	64	W4113X	3,8	-	-	-	-	-	-
	50	41,5	67	W4200X	3,9	50 - 36	W4200R107	-	-	-	-
	55	44,0	73	W4203X	4,0	55 - 41	W4203R110	55 - 36	W4203R107	55 - 32	W4203R104
	60	46,5	71	W4206X	4,1	60 - 50	W4206R200	60 - 46	W4206R113	60 - 36	W4206R107
	65	49,5	76	W4209X	4,1	65 - 55	W4209R203	65 - 50	W4209R200	65 - 46	W4209R113
	70	52,5	78	W4212X	4,2	70 - 60	W4212R206	70 - 55	W4212R203	-	-
	75	55,3	82	W4215X	4,3	75 - 65	W4215R209	75 - 60	W4215R206	-	-
	-	-	-	W4215X	-	-	75 - 55	W4215R203	75 - 50	W4215R200	-
W8000X (11.484 Nm)	80	58,5	84	W4302X	-	-	-	80 - 70	W4302R212	80 - 65	W4302R209
	-	-	-	W4302X	-	-	-	80 - 50	W4302R200	-	-
	85	62,0	86	W4085MX	4,5	-	-	-	-	-	-
	50	45,0	78	W8200X	8,1	-	-	-	-	-	-
	55	48,0	80	W8203X	8,1	-	-	-	-	-	-
	60	51,0	83	W8206X	8,1	-	-	-	-	-	-
	65	52,5	85	W8209X	8,1	65 - 50	W8209R200	-	-	-	-
	70	56,0	85	W8212X	7,9	70 - 55	W8212R203	-	-	-	-
	75	58,0	85	W8215X	7,9	75 - 60	W8215R206	75 - 55	W8215R203	-	-
	80	60,5	90	W8302X	8	80 - 65	W8302R209	80 - 60	W8302R206	80 - 55	W8302R203
-	-	-	-	-	-	80 - 50	W8302R200	-	-	-	
-	-	-	-	-	-	85 - 70	W8085R070M	85 - 65	W8085R065M	85 - 60	W8085R060M
-	-	-	-	-	-	85 - 55	W8085R055M	-	-	-	-
90	74,0	103	W8090MX	8,8	90 - 75	W8090R075M	-	-	-	-	
95	74,0	103	W8312X	8,8	95 - 80	W8312R302	95 - 75	W8312R215	-	-	
100	79,5	110	W8315X	9,3	-	-	-	-	-	-	
105	79,5	110	W8402X	9,3	-	-	-	-	-	-	

¹⁾ See page 144 for table of hexagon sizes of bolts, nuts and related thread diameters.

W-Series, Metric Cassettes and Reducers

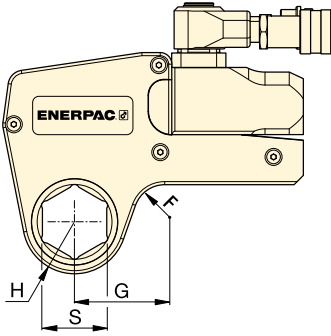

Hexagon Range:
50 - 155 mm

Maximum Operating Pressure:
690 bar

W
Series
X-Edition



▼ SELECTION CHART

Drive Unit Model Number	Hexagon Size ¹⁾	Nose Radius	Dim.	Model Nr. Cassette	Weight (kg)	Reducer		Reducer	
						Hexagon Reducer (mm)	Model Number Reducer	Hexagon Reducer (mm)	Model Number Reducer
W15000X (20.785 Nm)	65	59,0	89	W15209X	13,6	-	-	-	-
	70	59,0	89	W15212X	13,6	-	-	-	-
	75	62,0	91	W15215X	13,7	-	-	-	-
	80	64,5	93	W15302X	13,8	80 - 65	W15302R209	-	-
	85	69,5	97	W15085MX	14,1	85 - 70	W15085R070M	-	-
	90	75,0	102	W15090MX	14,5	90 - 75	W15090R075M	-	-
	95	75,0	102	W15312X	14,6	95 - 80	W15312R302	95 - 75	W15312R215
	100	80,5	103	W15315X	14,8	-	-	-	-
	105	80,5	103	W15402X	14,8	105 - 90	W15402R090M	-	-
	110	87,5	115	W15405X	15,1	110 - 95	W15110R095M	-	-
	115	87,5	115	W15115MX	15,1	115 - 100	W15115R100M	-	-
W22000X (30.506 Nm)	75	67,0	102	W22215X	22,0	-	-	-	-
	80	67,0	102	W22302X	21,6	80-60	W22302R206	80 - 55	W22302R203
	85	73,0	107	W22085MX	22,5	85-65	W22085MR209	85 - 60	W22085MR206
	90	77,9	113	W22090MX	23,4	90-70	W22090MR212	90 - 60	W22090MR206
	95	77,9	113	W22312X	22,9	95-75	W22312R215	-	-
	100	85,1	120	W22315X	24,3	-	-	-	-
	105	85,1	120	W22402X	23,4	-	-	-	-
	110	89,9	125	W22405X	24,6	-	-	-	-
	115	89,9	125	W22115MX	24,0	-	-	-	-
	120	95,0	130	W22412X	24,7	-	-	-	-
	123	95,0	130	W22123MX	24,4	-	-	-	-
	130	100,0	135	W22502X	25,0	-	-	-	-
	135	100,0	135	W22506X	23,9	135 - 105	W22506R402	-	-
W35000X (47.454 Nm)	80	76,0	129	W35302X	32,8	80 - 50	W35302R200	-	-
	85	76,0	129	W35085MX	32,3	-	-	-	-
	90	81,5	135	W35090MX	33,5	90 - 60	W35090R206	-	-
	95	81,5	135	W35312X	32,9	-	-	-	-
	100	87,0	139	W35315X	34,1	-	-	-	-
	105	87,0	139	W35402X	33,5	-	-	-	-
	110	93,0	146	W35405X	34,9	110 - 85	W35405R085M	-	-
	115	93,0	146	W35115MX	34,2	-	-	-	-
	120	100,0	153	W35412X	35,6	120 - 95	W35412R312	-	-
	123	100,0	153	W35123MX	35,0	-	-	-	-
	130	103,0	160	W35502X	35,8	130 - 105	W35502R402	-	-
	135	103,0	160	W35506X	34,6	135 - 110	W35506R405	-	-
	140	110,0	163	W35508X	36,2	140 - 115	W35508R115M	-	-
	145	110,0	163	W35512X	34,9	145 - 120	W35512R412	-	-
	150	114,0	164	W35514X	36,7	-	-	-	-
	151	114,0	164	W35151MX	36,5	-	-	-	-
	155	114,0	164	W35602X	35,3	155 - 130	W35602R502	-	-

¹⁾ See page 144 for table of hexagon sizes of bolts, nuts and related thread diameters.

▼ W4206SL ultraslim bi-hexagonal stepped width cassette with W4000X drive unit



Versatility

- Lean, stepped width design allows tool to be mounted over bolts where other tools won't fit
- Bi-Hexagonal cassette allows twice as many positioning points on nut or bolt
- Robust top mounted handle stays out of the way, providing safe fastening in hard to reach areas
- Uses same drive unit as standard W-series hexagon cassettes

Performance

- Premium components provide best-in-class endurance compared to other limited access tools

Ease of Use

- Few moving parts are easily accessible for quick field maintenance
- Fast release drive unit enables rapid exchange of cassettes, no tools required
- Top mounted straight handle for improved tool handling and safety

Accuracy

- Constant torque output provides accuracy of $\pm 3\%$ across the full stroke
- Calibration certificate shipped with every cassette.

Your easy and long lasting solution to difficult access bolting applications



UltraSlim: Designed for Tight Spots

Stepped width design provides easy access in confined areas. UltraSlim cassettes fit where standard solutions won't.



Built to Outperform

High endurance components keep working when others fail.



Top Mounted Straight Handle

The top mounted straight handle is standard and provides safe and easy positioning and access to hard to reach fasteners.

Straight handle (standard)	SWH6S
Angled handle (optional)	SWH6A



ATEX-certified. Calibration certificate included

All W-SL-Series UltraSlim cassettes are CE - ATEX certified and are shipped complete with a calibration certificate.

CE II 2 GD T4



Slim enough to fit and tough enough to last. This UltraSlim wrench is the perfect controlled bolting solution for this oil and gas flange. ▶

UltraSlim Bi-Hexagonal Cassettes



UltraSlim Cassettes

Accessing narrow spaces normally requires significantly reducing the width of the torque wrench. For the tool operator, this has always meant vastly reduced tool durability, and/or reduced torque output.

By using the highest grade materials, perfecting the geometry, and placing the positioning handle on top of the tool for safe fastening, Enerpac UltraSlim cassettes are able to provide greater torque, get into tighter spaces, and vastly outperform the competition in product durability*.

Durability of Key Components*

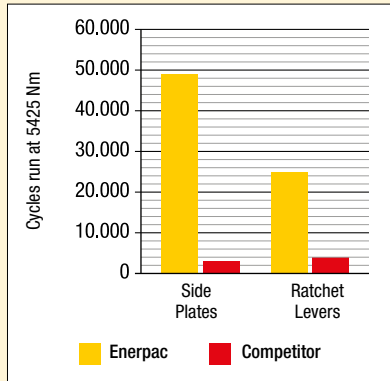

* Average test results, whereby three Enerpac 46 mm UltraSlim cassettes and three competitor 46 mm cassettes were tested at 5425 Nm for 50,000 cycles. The Enerpac side plates never broke for the full duration of the test.

W-SL Series UltraSlim



Nominal Torque Output:

5911 Nm

Bi-Hexagonal Range:

46 - 75 mm / 1¹³/₁₆ - 2¹⁵/₁₆"

Maximum Operating Pressure:

690 bar



Torque Pump Selection Matrix

System matched air and electric torque pumps that are ideal for use with hydraulic wrenches.

Page: **55**

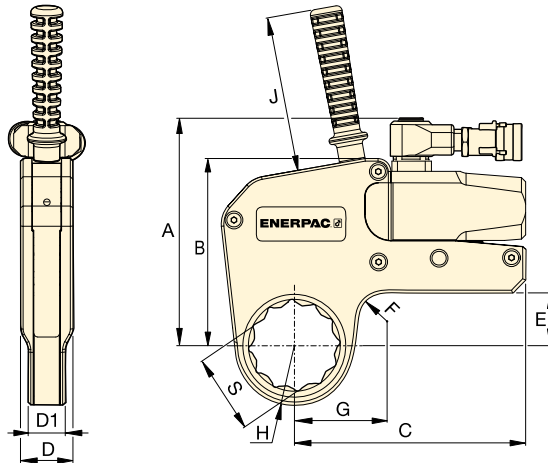

Torque Wrench Hoses

Use Enerpac THQ-Series hoses with W-Series torque wrenches to ensure the integrity of your hydraulic system.

2 meters long, 2 hoses	THQ702T
6 meters long, 2 hoses	THQ706T
12 meters long, 2 hoses	THQ712T

SELECTION CHART

Hexagonal Size		Nominal Torque @ 690 bar (Nm)	UltraSlim Cassette * Model Nr.	Minimum Torque @ 69 bar (Nm)	Nose Radius H (mm)	Dimensions (mm)									Drive Unit Model Nr. ** (sold separately)	
S (mm)	S (inch)					G	A	B	C	D	D1	E	F	J		(kg)
46	1 ¹³ / ₁₆	2685	W2113SL	269	36,5	59,6	140,7	109,3	147,7	32,4	25,4	24,0	20,0	120	2,2	W2000X
50	2	2685	W2200SL	269	38,8	61,1									2,2	
55	2 ³ / ₁₆	2685	W2203SL	269	41,5	63,2									2,2	
60	2 ³ / ₈	2685	W2206SL	269	44,5	65,1									2,2	
46	1 ¹³ / ₁₆	5911	W4113SL	591	39,5	67,2	175,6	144,5	178,5	40,5	28,6	40,8	20,0	120	4,6	W4000X
55	2 ³ / ₁₆	5911	W4203SL	591	44,0	68,7									4,6	
60	2 ³ / ₈	5911	W4206SL	591	48,0	71,6									4,7	
65	2 ⁹ / ₁₆	5911	W4209SL	591	50,5	74,1									4,7	
70	2 ³ / ₄	5911	W4212SL	591	53,5	75,6									4,7	
75	2 ¹⁵ / ₁₆	5911	W4215SL	591	56,0	76,0	4,7									

* Bi-Hexagonal Cassette includes top mounted straight handle.

** Cassette may also be used with W2000PX and W4000PX drive units, featuring double-swivel manifolds. Weight of drive units: W2000X = 1,4 kg; W4000X = 2,0 kg.

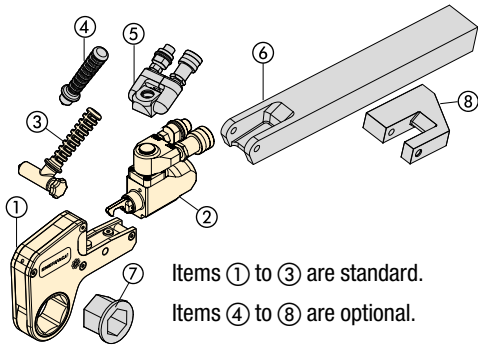

- ① Hexagon Cassette
- ② Drive Unit
- ③ Angled Positioning Handle
- ④ Straight Positioning Handle
- ⑤ Pro Series Swivel
- ⑥ Extended Reaction Arm
- ⑦ Reducer Insert
- ⑧ Reaction Paddle

Items ① to ③ are standard.
Items ④ to ⑧ are optional.

TSP WTE WRP Series



TSP-Series, Pro Series Swivel

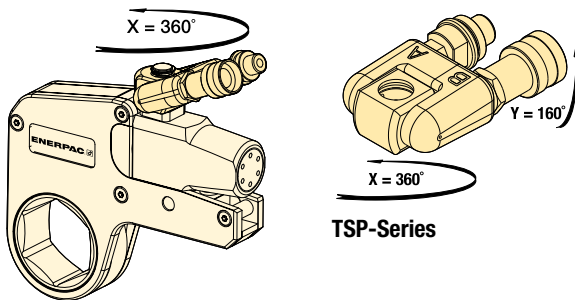

- Robust interlocking design
- 360° X-axis and 160° Y-axis rotation
- Increases tool fit in restricted access areas
- Simplifies hose placement
- Includes male and female couplers

For Torque Wrench Model Number	Model Number ¹⁾	Maximum Pressure (bar)	Weight (kg)
W2000X, W4000X, W8000X, W15000X, W22000X, W35000X	TSP300	690	0,2

¹⁾ To order a W-Series (X-edition) drive unit fitted with a TSP300 tilt and swivel manifold, insert a "P" prior to the "X" in the tool model number, example: **W2000PX**. TSP300 is designed for X-Edition tools only, and is not compatible with standard edition tools. For replacement components for existing tools, refer to repair sheet on www.enerpac.com

WTE-Series, Extended Reaction Arm

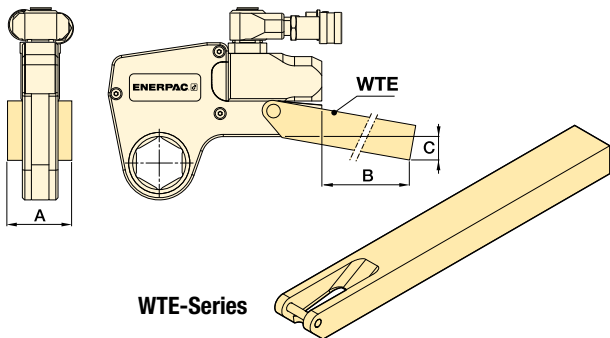

- Full torque rated
- Increases tool fit in restricted access areas.

For Torque Wrench Model Number	Model Number	Dimensions (mm)			Weight (kg) *
		A	B	C	
W2000X	WTE20	56	398	76	2,6
W4000X	WTE40	66	436	74	4,6
W8000X	WTE80	85	449	55	7,6
W15000X	WTE150	102	498	72	12,0
W22000X	WTE220	114	524	77	17,3
W35000X	WTE350	127	419	133	17,8

* Weights indicated are for the accessories only and do not include the wrench.

WRP-Series, Low Profile Reaction Paddles

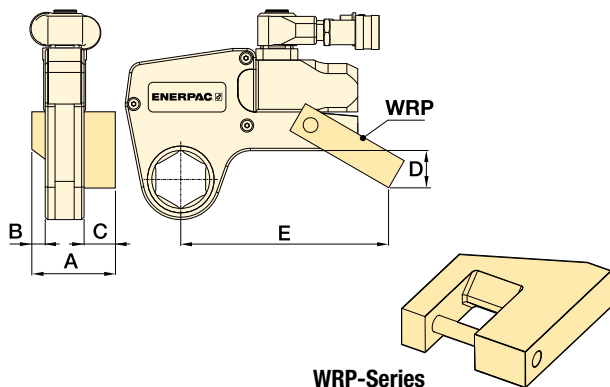

- Lightweight interchangeable design
- Allows for offset reaction when in-line reaction is not available.

For Torque Wrench Model Nr.	Model Number	Dimensions (mm)					Weight (kg) *
		A	B	C	D	E	
W2000X	WRP20	84	16	35	45	148	0,4
W4000X	WRP40	109	21	47	59	190	0,8
W8000X	WRP80	137	26	57	69	223	2,0
W15000X	WRP150	165	32	69	87	257	3,9
W22000X	WRP220	207	37	91	134	317	7,2
W35000X	WRP350	225	42	91	182	367	10,6

* Weights indicated are for the accessories only and do not include the wrench.

Custom Torque Wrenches and Bolt Tensioners

Looking for customized components to help solve your torquing problems? Enerpac has the experience and capabilities to help find solutions to your problems.

Enerpac hydraulic torque wrenches are designed to accommodate most bolting applications. However, due to space constraints, location of reaction points or need for special sockets and adapters, there is often a need for customized components.



◀ Custom S6000X hydraulic torque wrench fitted with a custom reaction arm/socket.



◀ Enerpac Multi Stud Tensioning (MST) system capable of tensioning every single stud in a joint simultaneously.



◀ Custom hydraulic tensioners to suit 5 inch studs load output 4200 kN.

Overview Custom Torque Wrenches and Bolt Tensioners



▲ Custom S11000X torque wrench with a custom torque link and reaction roller.

Customizable features on torque wrenches:

- Reaction Arms
- Torque Links (split or layered for extremely space restricted applications)
- Reaction Roller Assemblies
- Sockets (direct drive, castellated, peg-drive, stacked)
- Drives (direct Allen, spline, square drive size)
- Hexagon Reducing and Square Drive Inserts.

Customizable features on bolt tensioners:

- Adaptor kits with puller sleeves to suit different thread and/or pitch sizes
- Nut rotating sockets to accommodate different nut A/F (across flats) sizes
- Bridges to suit round or non-standard nuts or clear obstructions
- Sockets (direct drive, castellated, peg-drive, stacked)
- Load cells with various capacities
- Screw-on tensioners to overcome space restrictions.

▼ RSL-Drive Units with interchangeable RLP-Hexagon Cassette and RSQ-Square Drive Cassette



Safety and Performance

- Innovative design that completely encloses all moving parts and minimizes pinch points
- 30-35° rotation angle provides added productivity while avoiding “tool lock on” which is common with some torque wrench designs.

Simplicity

- Simple robust alloy steel design with just three moving parts for reduced maintenance
- Robust handles are available for both sides and the tops of cassettes to allow for extra maneuverability
- Designed to give optimum strength to weight and torque to weight ratios
- Minimum nose radius for trouble-free tool fit.

Versatility

- Interchangeable cassette design
- Wide range of hexagon sizes available for all applications
- Reaction arm has a simple dial lock for rapid change
- For use in multiple industrial, energy, and oil and gas applications.

Accuracy

- Constant torque output provides accuracy of $\pm 3\%$ across the full stroke.

Setting New Standards in Safety, Simplicity and Performance



RLP-Low Profile Hexagon Cassettes

For the metric and imperial sizes of hexagon cassettes see pages 28 - 32.



RSQ-Square Drive Cassettes

RSQ-Square Drive Cassettes are interchangeable with the RLP-Hexagon Cassettes. They all use the same RSL-drive unit.

Page: 36



Back-Up Spanners, BUS-Series

To be used to stop the back nut from turning during make up or break out. Two hexagon sizes in one tool.

Page: 9



Torque Pumps Selection Matrix

Visit enerpac.com for system matched air and electric torque pumps that are ideal for use with hydraulic torque wrenches.

Page: 55



Torque Wrench Hoses

Use Enerpac THQ-Series torque wrench hoses with RSL-Series torque wrenches to ensure the integrity of your hydraulic system.

2 meters long, 2 hoses	THQ702T
6 meters long, 2 hoses	THQ706T
12 meters long, 2 hoses	THQ712T

Drive Units for Hexagon & Square Drive Cassettes



One Drive, Two Tools

One RSL-Hydraulic Drive Unit fits RLP-Hexagon Cassette or RSQ-Square Drive Cassette.

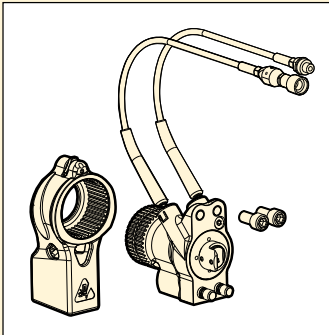

RSL

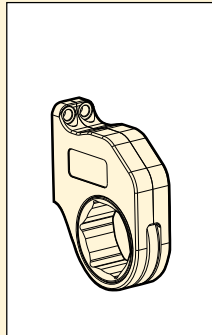

RLP... / RLP...SL

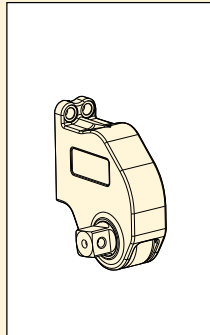

RSQ

RSL Series



Maximum Torque at 690 bar:

1909 - 37.965 Nm

Hexagon Range:

7/8 - 6 1/8 inch

Hexagon Range:

26 - 155 mm

Maximum Operating Pressure:

690 bar

▼ TORQUE WRENCH OPTIONS AND ACCESSORIES

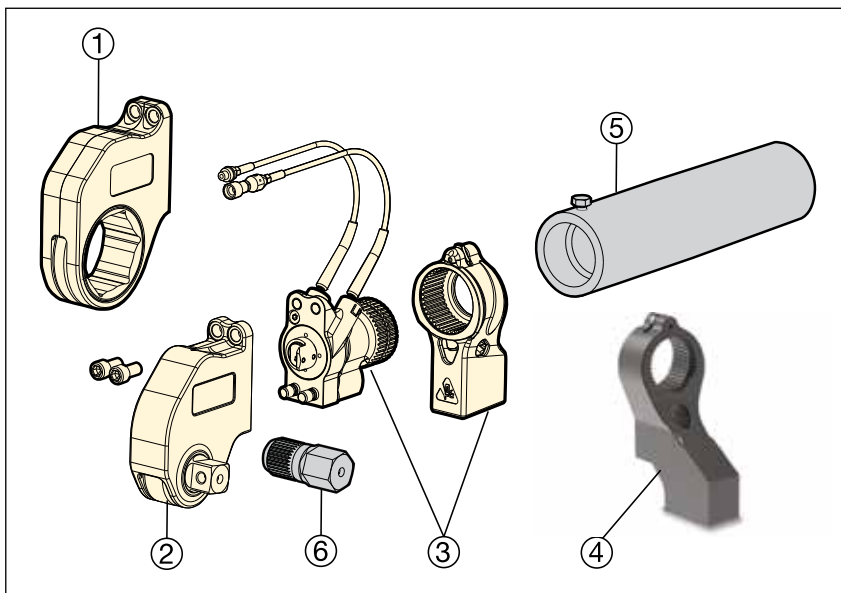

- ① RLP-Hexagon Cassette (pages 28-32)
RLP-SL-Slimline Hexagon Cassette (pages 34-35)
- ② RSQ-Square Drive Cassette (pages 36-37)
- ③ RSL-Drive Unit and Reaction Arm (page 27)

Optional Parts (page 33)

- ④ ERA-Extended Reaction Arm, for RSQ only
- ⑤ ERT-Extended Reaction Tube, for RLP only

Optional Parts (only available per request)

- ⑥ Hexagon Bit

▼ SELECTION CHART

Hexagon Cassette Range (A/F) (see pages 28 - 32 for sizes and model numbers)		Maximum Torque Output at 690 bar		Drive Unit Model Number	Minimum Torque Output at 69 bar		(kg)
(inch)	(mm)	(Ft.lbs)	(Nm)		(Ft.lbs)	(Nm)	
7/8 - 2 3/8	26 - 60	1408	1909	RSL1500	141	191	1,6
1 5/16 - 2 15/16	33 - 75	3080	4176	RSL3000	308	417	2,6
1 11/16 - 3 1/8	46 - 80	5303	7190	RSL5000	530	719	4,1
2 3/8 - 3 1/8	60 - 80	7862	10.659	RSL8000	786	1066	4,9
2 7/16 - 4 5/8	62 - 110	11.154	15.123	RSL11000	1115	1512	5,3
2 15/16 - 4 5/8	75 - 115	18.843	25.547	RSL19000	1884	2554	9,1
3 1/8 - 6 1/8	80 - 155	28.002	37.965	RSL28000	2800	3796	10,0



Select the Right Torque: Use Enerpac Bolting Integrity Software Solutions

Comprehensive on-line software solutions for Bolted Joint Integrity.

The software offers Tool selection, Bolt Load calculations and Tool pressure settings, as well as, a combined Application Data Sheet and Joint Completion Report. Custom Joint information can also be entered.

Hexagon Cassettes for RSL-Series

ENERPAC 

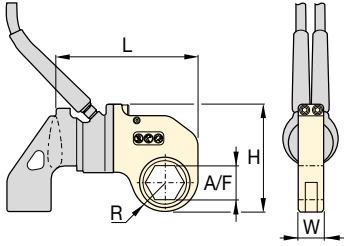

Hexagon Range:
7/8 - 6 1/8 inch



Hexagon Range:
26 - 155 mm

Maximum Operating Pressure:
690 bar

RSL Series



▼ **SELECTION CHART**

Drive Unit Model Number	Hexagon Size * A/F		Hexagon Cassette Model Number	Maximum Torque		Dimensions (inch)				 (lbs)	Dimensions (mm)				 (kg)
	(inch)	(mm)		(Ft.lbs)	(Nm)	R	L	W	H		R	L	W	H	
RSL1500	7/8	-	RLP1014	320	434	0.79	6.00	1.25	4.33	2.2	20,1	152,4	31,8	110,0	1,0
	1 1/16	26	RLP1101	640	868	0.95	6.05	1.25	4.50	2.2	24,1	153,7	31,8	114,3	1,0
	1 1/8	-	RLP1102	640	868	1.03	6.12	1.25	4.57	2.3	26,2	155,4	31,8	116,1	1,0
	1 3/16	30	RLP1103	640	868	1.03	6.12	1.25	4.57	2.3	26,2	155,4	31,8	116,1	1,0
	1 1/4	32	RLP1104	640	868	1.03	6.12	1.25	4.57	2.3	26,2	155,4	31,8	116,1	1,0
	1 5/16	33	RLP1105	900	1220	1.15	6.24	1.25	4.69	2.4	29,2	158,5	31,8	119,1	1,1
	1 3/8	35	RLP1106	900	1220	1.15	6.24	1.25	4.69	2.4	29,2	158,5	31,8	119,1	1,1
	1 7/16	36	RLP1107	900	1220	1.15	6.24	1.25	4.69	2.4	29,2	158,5	31,8	119,1	1,1
	1 1/2	38	RLP1108	1408	1909	1.31	6.41	1.25	4.86	2.7	33,3	162,8	31,8	123,4	1,2
	1 9/16	-	RLP1109	1408	1909	1.31	6.41	1.25	4.86	2.7	33,3	162,8	31,8	123,4	1,2
	1 5/8	41	RLP1110	1408	1909	1.31	6.41	1.25	4.86	2.7	33,3	162,8	31,8	123,4	1,2
	1 11/16	-	RLP1111	1408	1909	1.40	6.49	1.25	4.94	2.7	35,6	164,8	31,8	125,5	1,2
	1 3/4	-	RLP1112	1408	1909	1.40	6.49	1.25	4.94	2.7	35,6	164,8	31,8	125,5	1,2
	1 13/16	46	RLP1113	1408	1909	1.40	6.49	1.25	4.94	2.7	35,6	164,8	31,8	125,5	1,2
	1 7/8	-	RLP1114	1408	1909	1.48	6.58	1.25	5.03	2.7	37,6	167,1	31,8	127,8	1,2
	1 9/16	-	RLP1115	1408	1909	1.48	6.58	1.25	5.03	2.7	37,6	167,1	31,8	127,8	1,2
	2	50	RLP1200	1408	1909	1.48	6.58	1.25	5.03	2.7	37,6	167,1	31,8	127,8	1,2
	2 1/16	-	RLP1201	1408	1909	1.58	6.68	1.25	5.13	2.7	40,1	169,7	31,8	130,3	1,2
	2 1/8	-	RLP1202	1408	1909	1.58	6.68	1.25	5.13	2.7	40,1	169,7	31,8	130,3	1,2
	2 3/16	55	RLP1203	1408	1909	1.58	6.68	1.25	5.13	2.7	40,1	169,7	31,8	130,3	1,2
2 1/4	-	RLP1204	1408	1909	1.70	6.79	1.25	5.24	2.8	43,2	172,5	31,8	133,1	1,3	
2 5/16	-	RLP1205	1408	1909	1.70	6.79	1.25	5.24	2.8	43,2	172,5	31,8	133,1	1,3	
2 3/8	60	RLP1206	1408	1909	1.70	6.79	1.25	5.24	2.8	43,2	172,5	31,8	133,1	1,3	
RSL3000	1 5/16	33	RLP3105	900	1220	1.18	7.62	1.38	5.49	3.5	30,0	193,5	35,1	139,4	1,6
	1 3/8	35	RLP3106	900	1220	1.18	7.62	1.38	5.49	3.5	30,0	193,5	35,1	139,4	1,6
	1 7/16	36	RLP3107	900	1220	1.18	7.62	1.38	5.49	3.5	30,0	193,5	35,1	139,4	1,6
	1 1/2	38	RLP3108	1200	1627	1.32	7.77	1.38	5.63	3.9	33,5	197,4	35,1	143,0	1,8
	1 9/16	-	RLP3109	1200	1627	1.32	7.77	1.38	5.63	3.9	33,5	197,4	35,1	143,0	1,8
	1 5/8	41	RLP3110	1200	1627	1.32	7.77	1.38	5.63	3.9	33,5	197,4	35,1	143,0	1,8
	1 11/16	-	RLP3111	1900	2576	1.47	7.87	1.38	5.78	4.0	37,3	199,9	35,1	146,8	1,8
	1 3/4	-	RLP3112	1900	2576	1.47	7.87	1.38	5.78	4.0	37,3	199,9	35,1	146,8	1,8
	1 13/16	46	RLP3113	1900	2576	1.47	7.87	1.38	5.78	4.0	37,3	199,9	35,1	146,8	1,8
	1 7/8	-	RLP3114	2600	3526	1.60	8.04	1.38	5.92	4.5	40,6	204,2	35,1	150,4	2,0
	1 15/16	-	RLP3115	2600	3526	1.60	8.04	1.38	5.92	4.5	40,6	204,2	35,1	150,4	2,0
	2	50	RLP3200	2600	3526	1.60	8.04	1.38	5.92	4.5	40,6	204,2	35,1	150,4	2,0
	2 1/16	-	RLP3201	3080	4176	1.76	8.16	1.38	6.08	4.7	44,7	207,3	35,1	154,4	2,1
	2 1/8	-	RLP3202	3080	4176	1.76	8.16	1.38	6.08	4.7	44,7	207,3	35,1	154,4	2,1
	2 3/16	55	RLP3203	3080	4176	1.76	8.16	1.38	6.08	4.7	44,7	207,3	35,1	154,4	2,1
	2 1/4	-	RLP3204	3080	4176	1.84	8.25	1.38	6.15	4.8	46,7	209,6	35,1	156,2	2,2
	2 5/16	-	RLP3205	3080	4176	1.84	8.25	1.38	6.15	4.8	46,7	209,6	35,1	156,2	2,2
	2 3/8	60	RLP3206	3080	4176	1.84	8.25	1.38	6.15	4.8	46,7	209,6	35,1	156,2	2,2
	2 7/16	62	RLP3207	3080	4176	1.95	8.14	1.38	6.26	4.6	49,5	206,8	35,1	159,0	2,1
	2 1/2	63	RLP3208	3080	4176	1.95	8.14	1.38	6.26	4.6	49,5	206,8	35,1	159,0	2,1
2 9/16	65	RLP3209	3080	4176	1.95	8.14	1.38	6.26	4.6	49,5	206,8	35,1	159,0	2,1	
2 5/8	-	RLP3210	3080	4176	2.04	8.23	1.38	6.36	4.4	51,8	209,0	35,1	161,5	2,0	
2 11/16	-	RLP3211	3080	4176	2.04	8.23	1.38	6.36	4.4	51,8	209,0	35,1	161,5	2,0	
2 3/4	70	RLP3212	3080	4176	2.04	8.23	1.38	6.36	4.4	51,8	209,0	35,1	161,5	2,0	
2 13/16	-	RLP3213	3080	4176	2.16	8.34	1.38	6.54	4.7	54,9	211,8	35,1	166,1	2,1	
2 7/8	-	RLP3214	3080	4176	2.16	8.34	1.38	6.54	4.7	54,9	211,8	35,1	166,1	2,1	
2 15/16	75	RLP3215	3080	4176	2.16	8.34	1.38	6.54	4.7	54,9	211,8	35,1	166,1	2,1	

¹⁾ See page 144 for table of hexagon sizes of bolts, nuts and related thread diameters.

Hexagon Cassettes for RSL-Series

Hexagon Range:
7/8 - 6 1/8 inch

Hexagon Range:
26 - 155 mm

Maximum Operating Pressure:
690 bar

RSL Series

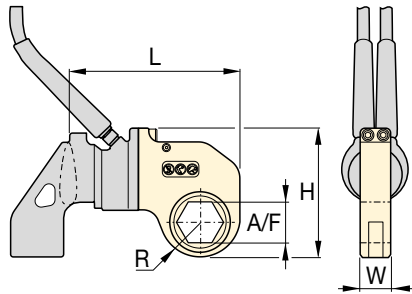

Slimline Stepped-Width Hexagon Cassettes

For accessing narrow spaces **RLP...SL** Stepped-Width Hexagon Cassettes are available. Slimline cassettes use same drive unit as standard RLP-cassettes.

Page: **35**

▼ **SELECTION CHART**

Drive Unit Model Number	Hexagon Size * A/F		Hexagon Cassette Model Number	Maximum Torque		Dimensions (inch)				⚖️ (lbs)	Dimensions (mm)				⚖️ (kg)
	(inch)	(mm)		(Ft.lbs)	(Nm)	R	L	W	H		R	L	W	H	
RSL5000	1 11/16	-	RLP5111	2600	3526	1.61	9.08	1.75	6.52	6.6	40,9	230,6	44,5	165,6	3,0
	1 3/4	-	RLP5112	2600	3526	1.61	9.08	1.75	6.52	6.6	40,9	230,6	44,5	165,6	3,0
	1 13/16	46	RLP5113	2600	3526	1.61	9.08	1.75	6.52	6.6	40,9	230,6	44,5	165,6	3,0
	1 7/8	-	RLP5114	2600	3526	1.61	9.08	1.75	6.52	6.6	40,9	230,6	44,5	165,6	3,0
	1 15/16	-	RLP5115	2600	3526	1.61	9.08	1.75	6.52	6.6	40,9	230,6	44,5	165,6	3,0
	2	50	RLP5200	2600	3526	1.61	9.08	1.75	6.52	6.6	40,9	230,6	44,5	165,6	3,0
	2 1/16	-	RLP5201	3500	4746	1.71	9.18	1.75	6.62	6.5	43,4	233,2	44,5	168,1	2,9
	2 1/8	-	RLP5202	3500	4746	1.71	9.18	1.75	6.62	6.5	43,4	233,2	44,5	168,1	2,9
	2 3/16	55	RLP5203	3500	4746	1.71	9.18	1.75	6.62	6.5	43,4	233,2	44,5	168,1	2,9
	2 1/4	-	RLP5204	4500	6102	1.87	9.34	1.75	6.78	7.0	47,5	237,2	44,5	172,2	3,2
	2 5/16	-	RLP5205	4500	6102	1.87	9.34	1.75	6.78	7.0	47,5	237,2	44,5	172,2	3,2
	2 3/8	60	RLP5206	4500	6102	1.87	9.34	1.75	6.78	7.0	47,5	237,2	44,5	172,2	3,2
	2 7/16	62	RLP5207	5303	7191	2.01	9.48	1.75	6.92	7.0	51,1	240,8	44,5	175,8	3,2
	2 1/2	63	RLP5208	5303	7191	2.01	9.48	1.75	6.92	7.0	51,1	240,8	44,5	175,8	3,2
	2 9/16	65	RLP5209	5303	7191	2.01	9.48	1.75	6.92	7.0	51,1	240,8	44,5	175,8	3,2
	2 5/8	-	RLP5210	5303	7191	2.16	9.63	1.75	7.07	7.5	54,9	244,6	44,5	179,6	3,4
	2 11/16	-	RLP5211	5303	7191	2.16	9.63	1.75	7.07	7.5	54,9	244,6	44,5	179,6	3,4
	2 3/4	70	RLP5212	5303	7191	2.16	9.63	1.75	7.07	7.5	54,9	244,6	44,5	179,6	3,4
	2 13/16	-	RLP5213	5303	7191	2.24	9.71	1.75	7.15	7.5	56,9	246,6	44,5	181,6	3,4
	2 7/8	-	RLP5214	5303	7191	2.24	9.71	1.75	7.15	7.5	56,9	246,6	44,5	181,6	3,4
2 15/16	75	RLP5215	5303	7191	2.24	9.71	1.75	7.15	7.5	56,9	246,6	44,5	181,6	3,4	
3	-	RLP5300	5303	7191	2.26	9.73	1.75	7.17	7.2	57,4	247,1	44,5	182,1	3,3	
3 1/16	-	RLP5301	5303	7191	2.26	9.73	1.75	7.17	7.2	57,4	247,1	44,5	182,1	3,3	
3 1/8	80	RLP5302	5303	7191	2.26	9.73	1.75	7.17	7.2	57,4	247,1	44,5	182,1	3,3	
RSL8000	2 5/8	60	RLP8206	4500	6102	1.87	9.53	2.25	7.00	8.9	47,5	242,1	57,2	177,8	4,0
	2 7/16	62	RLP8207	5800	7865	2.01	9.67	2.25	7.13	9.0	51,1	245,6	57,2	181,1	4,1
	2 1/2	63	RLP8208	5800	7865	2.01	9.67	2.25	7.13	9.0	51,1	245,6	57,2	181,1	4,1
	2 9/16	65	RLP8209	5800	7865	2.01	9.67	2.25	7.13	9.0	51,1	245,6	57,2	181,1	4,1
	2 5/8	-	RLP8210	7862	10.661	2.16	9.82	2.25	7.28	9.6	54,9	249,4	57,2	184,9	4,4
	2 11/16	-	RLP8211	7862	10.661	2.16	9.82	2.25	7.28	9.6	54,9	249,4	57,2	184,9	4,4
	2 3/4	70	RLP8212	7862	10.661	2.16	9.82	2.25	7.28	9.6	54,9	249,4	57,2	184,9	4,4
	2 13/16	-	RLP8213	7862	10.661	2.24	9.90	2.25	7.38	9.6	56,9	251,5	57,2	187,5	4,4
	2 7/8	-	RLP8214	7862	10.661	2.24	9.90	2.25	7.38	9.6	56,9	251,5	57,2	187,5	4,4
	2 15/16	75	RLP8215	7862	10.661	2.24	9.90	2.25	7.38	9.6	56,9	251,5	57,2	187,5	4,4
	3	-	RLP8300	7862	10.661	2.26	9.92	2.25	7.39	9.3	57,4	252,0	57,2	187,7	4,2
	3 1/16	-	RLP8301	7862	10.661	2.26	9.92	2.25	7.39	9.3	57,4	252,0	57,2	187,7	4,2
	3 1/8	80	RLP8302	7862	10.661	2.26	9.92	2.25	7.39	9.3	57,4	252,0	57,2	187,7	4,2

¹⁾ See page 144 for table of hexagon sizes of bolts, nuts and related thread diameters.

Hexagon Range:
7/8 - 6 1/8 inch

Hexagon Range:
26 - 155 mm

Maximum Operating Pressure:
690 bar

RSL Series

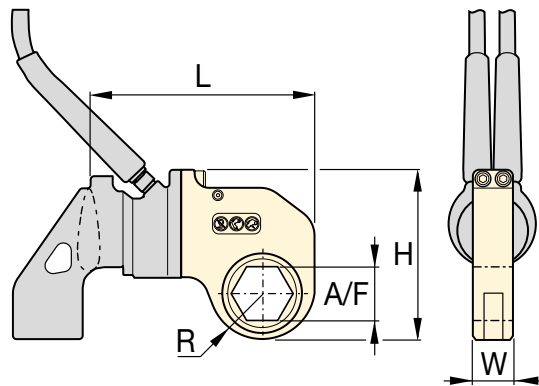

▼ **SELECTION CHART**

Drive Unit Model Number	Hexagon Size * A/F		Hexagon Cassette Model Number	Maximum Torque		Dimensions (inch)				⚖️ (lbs)	Dimensions (mm)				⚖️ (kg)
	(inch)	(mm)		(Ft.lbs)	(Nm)	R	L	W	H		R	L	W	H	
RSL11000	2 7/16	62	RLP11207	5800	7865	1.98	10.00	2.50	8.03	14.2	50,3	254,0	63,5	204,0	6,4
	2 1/2	-	RLP11208	5800	7865	1.98	10.00	2.50	8.03	14.2	50,3	254,0	63,5	204,0	6,4
	2 9/16	65	RLP11209	5800	7865	1.98	10.00	2.50	8.03	14.2	50,3	254,0	63,5	204,0	6,4
	2 5/8	-	RLP11210	7300	9899	2.19	11.20	2.50	8.23	14.8	55,6	284,5	63,5	209,0	6,7
	2 11/16	-	RLP11211	7300	9899	2.19	11.20	2.50	8.23	14.8	55,6	284,5	63,5	209,0	6,7
	2 3/4	70	RLP11212	7300	9899	2.19	11.20	2.50	8.23	14.8	55,6	284,5	63,5	209,0	6,7
	2 13/16	-	RLP11213	9000	12.204	2.29	11.31	2.50	8.34	14.8	58,2	287,3	63,5	211,8	6,7
	2 7/8	-	RLP11214	9000	12.204	2.29	11.31	2.50	8.34	14.8	58,2	287,3	63,5	211,8	6,7
	2 15/16	75	RLP11215	9000	12.204	2.29	11.31	2.50	8.34	14.8	58,2	287,3	63,5	211,8	6,7
	3	-	RLP11300	11.154	15.125	2.43	11.44	2.50	8.47	15.2	61,7	290,6	63,5	215,1	6,9
	3 1/16	-	RLP11301	11.154	15.125	2.43	11.44	2.50	8.47	15.2	61,7	290,6	63,5	215,1	6,9
	3 1/8	80	RLP11302	11.154	15.125	2.43	11.44	2.50	8.47	15.2	61,7	290,6	63,5	215,1	6,9
	3 3/16	-	RLP11303	11.154	15.125	2.60	11.71	2.50	8.64	16.6	66,0	297,4	63,5	219,5	7,5
	-	85	RLP11085M	11.154	15.125	2.60	11.71	2.50	8.64	16.6	66,0	297,4	63,5	219,5	7,5
	3 1/4	-	RLP11304	11.154	15.125	2.60	11.71	2.50	8.64	16.6	66,0	297,4	63,5	219,5	7,5
	3 5/16	-	RLP11305	11.154	15.125	2.60	11.71	2.50	8.64	16.6	66,0	297,4	63,5	219,5	7,5
	3 3/8	-	RLP11306	11.154	15.125	2.60	11.71	2.50	8.64	16.6	66,0	297,4	63,5	219,5	7,5
	3 7/16	-	RLP11307	11.154	15.125	2.60	11.71	2.50	8.64	16.6	66,0	297,4	63,5	219,5	7,5
	3 1/2	-	RLP11308	11.154	15.125	2.60	11.71	2.50	8.64	16.6	66,0	297,4	63,5	219,5	7,5
	-	90	RLP11090M	11.154	15.125	2.88	11.89	2.50	8.92	17.2	73,2	302,0	63,5	226,6	7,8
	3 9/16	-	RLP11309	11.154	15.125	2.88	11.89	2.50	8.92	17.2	73,2	302,0	63,5	226,6	7,8
	3 5/8	-	RLP11310	11.154	15.125	2.88	11.89	2.50	8.92	17.2	73,2	302,0	63,5	226,6	7,8
	3 11/16	-	RLP11311	11.154	15.125	2.88	11.89	2.50	8.92	17.2	73,2	302,0	63,5	226,6	7,8
	3 3/4	95	RLP11312	11.154	15.125	2.88	11.89	2.50	8.92	17.2	73,2	302,0	63,5	226,6	7,8
	3 13/16	-	RLP11313	11.154	15.125	2.88	11.89	2.50	8.92	17.2	73,2	302,0	63,5	226,6	7,8
	3 7/8	-	RLP11314	11.154	15.125	2.88	11.89	2.50	8.92	17.2	73,2	302,0	63,5	226,6	7,8
	3 15/16	100	RLP11315	11.154	15.125	2.98	12.00	2.50	9.03	16.4	75,7	304,8	63,5	229,4	7,4
	4	-	RLP11400	11.154	15.125	2.98	12.00	2.50	9.03	16.4	75,7	304,8	63,5	229,4	7,4
	4 1/16	-	RLP11401	11.154	15.125	2.98	12.00	2.50	9.03	16.4	75,7	304,8	63,5	229,4	7,4
	4 1/8	105	RLP11402	11.154	15.125	2.98	12.00	2.50	9.03	16.4	75,7	304,8	63,5	229,4	7,4
	4 1/4	-	RLP11404	11.154	15.125	2.98	12.00	2.50	9.03	16.4	75,7	304,8	63,5	229,4	7,4
	4 5/16	110	RLP11405	11.154	15.125	3.25	12.27	2.50	9.30	17.6	82,6	311,7	63,5	236,2	8,0
4 1/2	-	RLP11408	11.154	15.125	3.25	12.27	2.50	9.30	17.6	82,6	311,7	63,5	236,2	8,0	
-	115	RLP11115M	11.154	15.125	3.25	12.27	2.50	9.30	17.6	82,6	311,7	63,5	236,2	8,0	
4 5/8	-	RLP11410	11.154	15.125	3.25	12.27	2.50	9.30	17.6	82,6	311,7	63,5	236,2	8,0	

¹⁾ See page 144 for table of hexagon sizes of bolts, nuts and related thread diameters.

Hexagon Cassettes for RSL-Series

Hexagon Range:
7/8 - 6 1/8 inch

Hexagon Range:
26 - 155 mm

Maximum Operating Pressure:
690 bar

**RSL
Series**

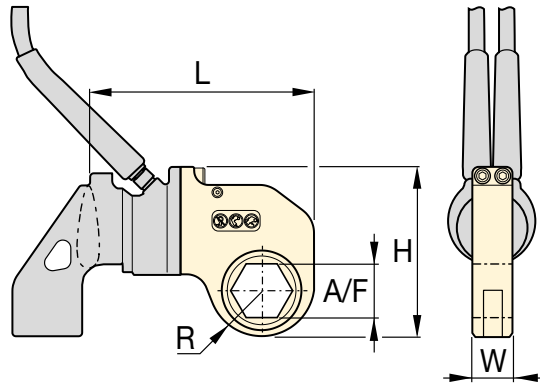

▼ SELECTION CHART

Drive Unit Model Number	Hexagon Size * A/F		Hexagon Cassette Model Number	Maximum Torque		Dimensions (inch)					Dimensions (mm)				
	(inch)	(mm)		(Ft.lbs)	(Nm)	R	L	W	H		(lbs)	R	L	W	
RSL19000	2 ¹⁵ / ₁₆	75	RLP19215	11.000	14.916	2.45	12.72	2.75	9.44	21.5	62,2	323,1	69,9	239,8	9,8
	3	-	RLP19300	11.000	14.916	2.45	12.72	2.75	9.44	21.5	62,2	323,1	69,9	239,8	9,8
	3 ¹ / ₁₆	-	RLP19301	11.000	14.916	2.45	12.72	2.75	9.44	21.5	62,2	323,1	69,9	239,8	9,8
	3 ¹ / ₈	80	RLP19302	11.000	14.916	2.45	12.72	2.75	9.44	21.5	62,2	323,1	69,9	239,8	9,8
	3 ³ / ₁₆	-	RLP19303	16.000	21.696	2.77	13.04	2.75	9.76	22.6	70,4	331,2	69,9	247,9	10,3
	-	85	RLP19085M	16.000	21.696	2.77	13.04	2.75	9.76	22.6	70,4	331,2	69,9	247,9	10,3
	3 ¹ / ₄	-	RLP19304	16.000	21.696	2.77	13.04	2.75	9.76	22.6	70,4	331,2	69,9	247,9	10,3
	3 ⁵ / ₁₆	-	RLP19305	16.000	21.696	2.77	13.04	2.75	9.76	22.6	70,4	331,2	69,9	247,9	10,3
	3 ³ / ₈	-	RLP19306	16.000	21.696	2.77	13.04	2.75	9.76	22.6	70,4	331,2	69,9	247,9	10,3
	3 ⁷ / ₁₆	-	RLP19307	16.000	21.696	2.77	13.04	2.75	9.76	22.6	70,4	331,2	69,9	247,9	10,3
	3 ¹ / ₂	-	RLP19308	16.000	21.696	2.77	13.04	2.75	9.76	22.6	70,4	331,2	69,9	247,9	10,3
	-	90	RLP19090M	18.843	25.551	2.95	13.22	2.75	9.94	23.8	74,9	335,8	69,9	252,5	10,8
	3 ⁹ / ₁₆	-	RLP19309	18.843	25.551	2.95	13.22	2.75	9.94	23.8	74,9	335,8	69,9	252,5	10,8
	3 ⁵ / ₈	-	RLP19310	18.843	25.551	2.95	13.22	2.75	9.94	23.8	74,9	335,8	69,9	252,5	10,8
	3 ¹¹ / ₁₆	-	RLP19311	18.843	25.551	2.95	13.22	2.75	9.94	23.8	74,9	335,8	69,9	252,5	10,8
	3 ³ / ₄	95	RLP19312	18.843	25.551	2.95	13.22	2.75	9.94	23.8	74,9	335,8	69,9	252,5	10,8
	3 ¹³ / ₁₆	-	RLP19313	18.843	25.551	2.95	13.22	2.75	9.94	23.8	74,9	335,8	69,9	252,5	10,8
	3 ⁷ / ₈	-	RLP19314	18.843	25.551	2.95	13.22	2.75	9.94	23.8	74,9	335,8	69,9	252,5	10,8
	3 ¹⁵ / ₁₆	100	RLP19315	18.843	25.551	3.30	13.57	2.75	10.28	25.3	83,8	344,7	69,9	261,1	11,5
	4	-	RLP19400	18.843	25.551	3.30	13.57	2.75	10.28	25.3	83,8	344,7	69,9	261,1	11,5
	4 ¹ / ₁₆	-	RLP19401	18.843	25.551	3.30	13.57	2.75	10.28	25.3	83,8	344,7	69,9	261,1	11,5
	4 ¹ / ₈	105	RLP19402	18.843	25.551	3.30	13.57	2.75	10.28	25.3	83,8	344,7	69,9	261,1	11,5
	4 ³ / ₁₆	-	RLP19403	18.843	25.551	3.30	13.57	2.75	10.28	25.3	83,8	344,7	69,9	261,1	11,5
	4 ¹ / ₄	-	RLP19404	18.843	25.551	3.30	13.57	2.75	10.28	25.3	83,8	344,7	69,9	261,1	11,5
	4 ⁵ / ₁₆	110	RLP19405	18.843	25.551	3.44	13.71	2.75	10.43	25.6	87,4	348,2	69,9	264,9	11,6
	4 ³ / ₈	-	RLP19406	18.843	25.551	3.44	13.71	2.75	10.43	25.6	87,4	348,2	69,9	264,9	11,6
	4 ⁷ / ₁₆	-	RLP19407	18.843	25.551	3.44	13.71	2.75	10.43	25.6	87,4	348,2	69,9	264,9	11,6
	4 ¹ / ₂	-	RLP19408	18.843	25.551	3.44	13.71	2.75	10.43	25.6	87,4	348,2	69,9	264,9	11,6
	-	115	RLP19115M	18.843	25.551	3.44	13.71	2.75	10.43	25.6	87,4	348,2	69,9	264,9	11,6
	4 ⁹ / ₁₆	-	RLP19409	18.843	25.551	3.44	13.71	2.75	10.43	25.6	87,4	348,2	69,9	264,9	11,6
4 ⁵ / ₈	-	RLP19410	18.843	25.551	3.44	13.71	2.75	10.43	25.6	87,4	348,2	69,9	264,9	11,6	

¹⁾ See page 144 for table of hexagon sizes of bolts, nuts and related thread diameters.

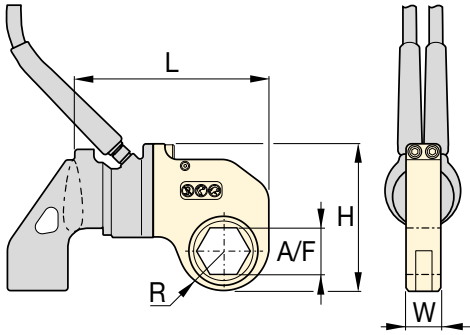

Hexagon Range:
7/8 - 6 1/8 inch

Hexagon Range:
26 - 155 mm

Maximum Operating Pressure:
690 bar

RSL Series



▼ **SELECTION CHART**

Drive Unit Model Number	Hexagon Size * A/F		Hexagon Cassette Model Number	Maximum Torque		Dimensions (inch)				🏋️ (lbs)	Dimensions (mm)				🏋️ (kg)
	(inch)	(mm)		(Ft.lbs)	(Nm)	R	L	W	H		R	L	W	H	
RSL28000	3 1/8	80	RLP28302	16.000	21.696	2.56	14.36	3.00	10.54	27.6	65,0	364,7	76,2	267,7	12,5
	3 3/16	-	RLP28303	16.000	21.696	2.56	14.36	3.00	10.54	27.6	65,0	364,7	76,2	267,7	12,5
	-	85	RLP28085M	16.000	21.696	2.56	14.36	3.00	10.54	27.6	65,0	364,7	76,2	267,7	12,5
	3 1/4	-	RLP28304	16.000	21.696	2.56	14.36	3.00	10.54	27.6	65,0	364,7	76,2	267,7	12,5
	3 5/16	-	RLP28305	16.000	21.696	2.56	14.36	3.00	10.54	27.6	65,0	364,7	76,2	267,7	12,5
	3 3/8	-	RLP28306	16.000	21.696	2.56	14.36	3.00	10.54	27.6	65,0	364,7	76,2	267,7	12,5
	3 7/16	-	RLP28307	16.000	21.696	2.56	14.36	3.00	10.54	27.6	65,0	364,7	76,2	267,7	12,5
	3 1/2	-	RLP28308	16.000	21.696	2.56	14.36	3.00	10.54	27.6	65,0	364,7	76,2	267,7	12,5
	-	90	RLP28090M	22.000	29.832	2.92	14.36	3.00	10.77	28.8	74,2	364,7	76,2	273,6	13,1
	3 9/16	-	RLP28309	22.000	29.832	2.92	14.36	3.00	10.77	28.8	74,2	364,7	76,2	273,6	13,1
	3 5/8	-	RLP28310	22.000	29.832	2.92	14.36	3.00	10.77	28.8	74,2	364,7	76,2	273,6	13,1
	3 11/16	-	RLP28311	22.000	29.832	2.92	14.36	3.00	10.77	28.8	74,2	364,7	76,2	273,6	13,1
	3 3/4	95	RLP28312	22.000	29.832	2.92	14.36	3.00	10.77	28.8	74,2	364,7	76,2	273,6	13,1
	3 13/16	-	RLP28313	22.000	29.832	2.92	14.36	3.00	10.77	28.8	74,2	364,7	76,2	273,6	13,1
	3 7/8	-	RLP28314	22.000	29.832	2.92	14.36	3.00	10.77	28.8	74,2	364,7	76,2	273,6	13,1
	3 15/16	100	RLP28315	28.002	37.971	3.29	14.47	3.00	11.14	31.7	83,6	367,5	76,2	283,0	14,4
	4	-	RLP28400	28.002	37.971	3.29	14.47	3.00	11.14	31.7	83,6	367,5	76,2	283,0	14,4
	4 1/16	-	RLP28401	28.002	37.971	3.29	14.47	3.00	11.14	31.7	83,6	367,5	76,2	283,0	14,4
	4 1/8	105	RLP28402	28.002	37.971	3.29	14.47	3.00	11.14	31.7	83,6	367,5	76,2	283,0	14,4
	4 3/16	-	RLP28403	28.002	37.971	3.29	14.47	3.00	11.14	31.7	83,6	367,5	76,2	283,0	14,4
	4 1/4	-	RLP28404	28.002	37.971	3.29	14.47	3.00	11.14	31.7	83,6	367,5	76,2	283,0	14,4
	4 5/16	110	RLP28405	28.002	37.971	3.43	14.61	3.00	11.28	31.5	87,1	371,1	76,2	286,5	14,3
	4 3/8	-	RLP28406	28.002	37.971	3.43	14.61	3.00	11.28	31.5	87,1	371,1	76,2	286,5	14,3
	4 7/16	-	RLP28407	28.002	37.971	3.43	14.61	3.00	11.28	31.5	87,1	371,1	76,2	286,5	14,3
	4 1/2	-	RLP28408	28.002	37.971	3.43	14.61	3.00	11.28	31.5	87,1	371,1	76,2	286,5	14,3
	-	115	RLP28115M	28.002	37.971	3.43	14.61	3.00	11.28	31.5	87,1	371,1	76,2	286,5	14,3
	4 9/16	-	RLP28409	28.002	37.971	3.43	14.61	3.00	11.28	31.5	87,1	371,1	76,2	286,5	14,3
	4 5/8	-	RLP28410	28.002	37.971	3.43	14.61	3.00	11.28	31.5	87,1	371,1	76,2	286,5	14,3
	4 3/4	120	RLP28412	28.002	37.971	3.65	14.83	3.00	11.50	33.5	92,7	376,7	76,2	292,1	15,2
	-	123	RLP28123M	28.002	37.971	3.65	14.83	3.00	11.50	33.5	92,7	376,7	76,2	292,1	15,2
	4 7/8	-	RLP28414	28.002	37.971	3.65	14.83	3.00	11.50	33.5	92,7	376,7	76,2	292,1	15,2
	5	-	RLP28500	28.002	37.971	3.65	14.83	3.00	11.50	33.5	92,7	376,7	76,2	292,1	15,2
	5 1/8	130	RLP28502	28.002	37.971	3.79	14.97	3.00	11.64	33.2	96,3	380,2	76,2	295,7	15,1
	5 3/16	-	RLP28503	28.002	37.971	3.79	14.97	3.00	11.64	33.2	96,3	380,2	76,2	295,7	15,1
	5 1/4	-	RLP28504	28.002	37.971	3.79	14.97	3.00	11.64	33.2	96,3	380,2	76,2	295,7	15,1
	5 3/8	135	RLP28506	28.002	37.971	3.79	14.97	3.00	11.64	33.2	96,3	380,2	76,2	295,7	15,1
	5 1/2	140	RLP28508	28.002	37.971	4.05	15.23	3.00	11.90	33.5	102,9	386,8	76,2	302,3	15,2
	5 9/16	-	RLP28509	28.002	37.971	4.05	15.23	3.00	11.90	33.5	102,9	386,8	76,2	302,3	15,2
	5 5/8	-	RLP28510	28.002	37.971	4.05	15.23	3.00	11.90	33.5	102,9	386,8	76,2	302,3	15,2
	5 3/4	145	RLP28512	28.002	37.971	4.05	15.23	3.00	11.90	33.5	102,9	386,8	76,2	302,3	15,2
5 7/8	150	RLP28514	28.002	37.971	4.22	15.48	3.00	12.15	34.5	107,2	393,2	76,2	308,6	15,6	
-	151	RLP28151M	28.002	37.971	4.22	15.48	3.00	12.15	34.5	107,2	393,2	76,2	308,6	15,6	
6	-	RLP28600	28.002	37.971	4.22	15.48	3.00	12.15	34.5	107,2	393,2	76,2	308,6	15,6	
6 1/8	155	RLP28602	28.002	37.971	4.22	15.48	3.00	12.15	34.5	107,2	393,2	76,2	308,6	15,6	

¹⁾ See page 144 for table of hexagon sizes of bolts, nuts and related thread diameters.

Accessories for RSL-Series Torque Wrenches

TWMP503, Torque Wrench Moly Paste

- Enerpac 503 Moly Paste reduces friction on threaded fasteners – bolts, nuts and studs
- The low and uniform friction coefficient of 0.06 (torque coefficient, K, of 0.10) creates reliable assembly conditions
- This lubricant stays in place through heat, load and vibration to insure trouble-free disassembly from -29 °C to 400 °C (-20 °F to 750 °F)
- Can of 1,8 kg (4 lb).

▼ TWMP503



for
RSL
Series



ERA-Series, Extended Reaction Arms

For Torque Wrench Model Nr.	Model Number	Dimensions (mm)					 (kg)
		A	B	C	D	E	
RSL1500	ERA15114	87	145	195	29	36	0,9
	ERA15228	113	181	230	29	36	1,8
	ERA15342	139	226	276	29	36	2,7
	ERA15456	164	236	286	29	36	3,6
	ERA15570	189	287	337	29	36	4,5
RSL3000	ERA30114	105	195	257	34	41	2,7
	ERA30228	131	231	293	34	41	3,6
	ERA30342	156	266	328	34	41	4,5
	ERA30456	181	302	364	34	41	5,4
RSL5000	ERA50114	131	208	284	44	48	4,1
	ERA50228	156	243	320	44	48	5,0
	ERA50342	181	279	355	44	48	5,9
	ERA50456	207	314	391	44	48	6,8
RSL11000	ERA110114	125	219	296	51	59	6,3
	ERA110228	150	255	331	51	59	7,3
	ERA110342	176	291	367	51	59	8,2
	ERA110456	201	326	402	51	59	9,1
RSL28000	ERA280228	171	335	411	57	85	11,3
	ERA280342	197	370	447	57	85	13,6

- Only to be used on RSL-drive units with RSQ-square drive wrenches
- Used in place of standard reaction arm
- Lightweight interchangeable design
- Full torque rated.

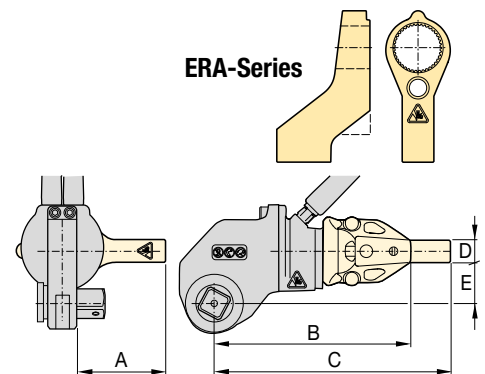

NOTE: Extended Reaction Arms for RSL8000 and RSL19000 are available on request.

ERT-Series, Extended Reaction Tubes

For Torque Wrench Model Nr.	Model Number	Dimensions (mm)			 (kg)
		A	B	Ø C	
RSL1500	ERT152	157	51	57	0,9
	ERT156	259	152	57	1,6
	ERT159	335	229	57	2,5
	ERT1512	411	305	57	3,4
	ERT1524	716	610	57	6,7
RSL3000	ERT3012	429	305	70	3,0
	ERT3024	734	610	70	5,9
RSL5000	ERT5012	451	305	89	5,6
	ERT5024	756	610	89	11,3
RSL11000	ERT1106	330	152	95	2,1
	ERT11012	483	305	95	4,1
	ERT11018	635	457	95	6,1
	ERT11024	787	610	95	8,4
RSL19000	ERT19024	800	610	127	16,7
RSL28000	ERT2806	351	152	127	3,6
	ERT28012	503	305	127	7,3
	ERT28018	655	457	127	10,9
	ERT28024	808	610	127	16,6

- Only to be used on RSL-drive units with RLP-hexagon cassettes
- Used in place of standard reaction arm
- One piece steel design, durable and simple
- Increases tool fit in restricted access areas
- Full torque rated.

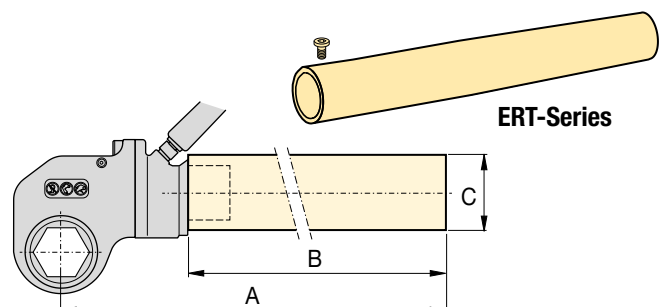

NOTE: Extended Reaction Tubes for RSL8000 are available on request.

▼ RSL-Drive Unit with interchangeable RLP...SL Slimline Hexagon Cassette



Simplicity

- Minimum nose radius for trouble-free tool fit which makes it uniquely equipped to access tight spaces
- Simple robust alloy steel design with three moving parts for reduced maintenance
- Robust handles are available for both sides and the tops of cassettes to allow for extra maneuverability
- Proven to perform even in the harshest environments
- Reaction arm has a simple dial lock for rapid change
- Designed to give optimum strength to weight and torque to weight ratios.

Versatility

- Interchangeable cassette design
- Drive unit / hexagon cassette combination for limited height in line solutions
- Wide range of hexagon sizes available for all applications.

Accuracy

- Constant torque output provides accuracy of $\pm 3\%$ across the full stroke.

Ease of Use

- Few moving parts are easily accessible for quick field maintenance
- Innovative design that completely encloses all moving parts and minimizes pinch points.

Setting New Standards in Safety, Simplicity and Performance



Torque Pumps

Visit enerpac.com for system matched air and electric torque pumps that are ideal for use with hydraulic torque wrenches.

Page: 55



Torque Wrench Options and Accessories

Optional accessories are available for maximum versatility. Please contact your Enerpac representative to help you select the optimum solution for your application.

Page: 33



Back-Up Spanners

To be used to stop the back nut from turning during make up or break out. Two hexagon sizes in one tool.

Hexagon Sizes (A/F)		Back-Up Spanner Model Number
mm	inch	
27 - 32	1 ¹ / ₁₆ - 1 ¹ / ₄ "	BUS01
36 - 41	1 ⁷ / ₁₆ - 1 ⁵ / ₈ "	BUS02
46 - 50	1 ¹³ / ₁₆ - 2"	BUS03
55 - 60	2 ³ / ₁₆ - 2 ³ / ₈ "	BUS04
65 - 70	2 ⁹ / ₁₆ - 2 ³ / ₄ "	BUS05
75 - 80	2 ¹⁵ / ₁₆ - 3 ¹ / ₈ "	BUS06
-	3 ¹ / ₂ - 3 ⁷ / ₈ "	BUS07
-	4 ¹ / ₄ - 4 ⁵ / ₈ "	BUS08
85 - 90	-	BUS09
95 - 100	3 ³ / ₄ - 3 ¹⁵ / ₁₆ "	BUS10
105 - 110	4 ¹ / ₈ - 4 ¹⁵ / ₁₆ "	BUS11
115 - 120	-	BUS12

Page: 9

Slimline Stepped-Width Hexagon Cassettes for RSL-Series



Slimline Stepped-Width Hexagon Cassettes

Accessing narrow spaces normally requires significantly reducing the width of the torque wrench. For the tool operator, this has always meant vastly reduced tool durability, and/or reduced torque output.

By using the highest-grade materials and perfecting the geometry, the RSL Slimline cassettes are able to provide greater torque, get into tighter spaces, and vastly outperform the competition in product durability.

RSL Series



Hexagon Range:

1 1/4 - 3 3/16 inch

Hexagon Range:

32 - 80 mm

Maximum Operating Pressure:

690 bar

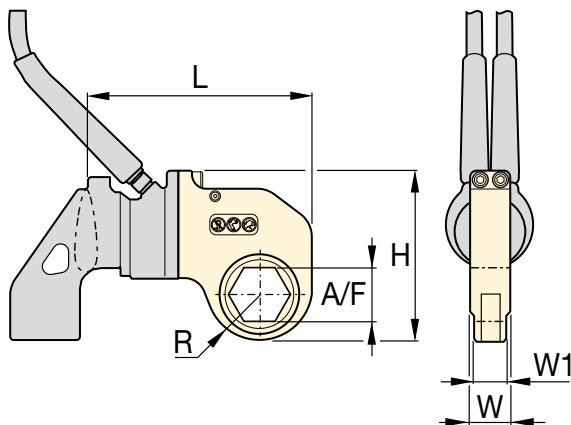

Select the Right Torque

Choose your Enerpac Torque Wrench using the untightening rule of thumb: Loosening torque equals about 250% of tightening torque.

Page: 139



Torque Wrench Hoses

Use Enerpac THQ700-Series torque wrench hoses with RSL-Series torque wrenches to ensure the integrity of your hydraulic system.

Page: 100

▼ SELECTION CHART

Drive Unit Model Number	Hexagon Size A/F		Slimline Hexagon Cassette Model Nr.	Maximum Torque		Dimensions (inch)					Dimensions (mm)						
	(inch)	(mm)		(Ft.lbs)	(Nm)	R	L	W	W1	H	(lbs)	R	L	W	W1	H	(kg)
RSL1500	1 1/4	32	RLP1104SL	375	509	1.03	6.12	1.25	1.00	4.57	2.2	26,2	155,4	31,8	25,4	116,1	1,0
	1 7/16	36	RLP1107SL	658	892	1.15	6.24	1.25	1.00	4.69	2.3	29,2	158,5	31,8	25,4	119,1	1,0
	1 5/8	41	RLP1110SL	831	1127	1.31	6.41	1.25	1.00	4.86	2.7	33,3	162,8	31,8	25,4	123,4	1,2
	1 13/16	46	RLP1113SL	831	1127	1.40	6.49	1.25	1.00	4.94	2.7	35,6	164,8	31,8	25,4	125,5	1,2
	2	50	RLP1200SL	831	1127	1.48	6.58	1.25	1.00	5.03	2.7	37,6	167,1	31,8	25,4	127,8	1,2
RSL3000	2	50	RLP3200SL	1354	1836	1.60	8.04	1.38	1.13	5.92	4.5	40,6	204,2	35,1	28,7	150,4	2,0
	2 3/16	55	RLP3203SL	1604	2175	1.76	8.16	1.38	1.13	6.08	4.7	44,7	207,3	35,1	28,7	154,4	2,1
	2 3/8	60	RLP3206SL	1604	2175	1.84	8.25	1.38	1.13	6.15	4.8	46,7	209,6	35,1	28,7	156,2	2,2
	2 9/16	65	RLP3209SL	1604	2175	1.95	8.14	1.38	1.13	6.26	4.6	49,5	206,8	35,1	28,7	159,0	2,1
	2 3/4	70	RLP3212SL	1604	2175	2.04	8.23	1.38	1.13	6.36	4.4	51,8	209,0	35,1	28,7	161,5	2,0
	2 15/16	75	RLP3215SL	1604	2175	2.16	8.34	1.38	1.13	6.54	4.7	54,9	211,8	35,1	28,7	166,1	2,1
RSL5000	2 3/4	70	RLP5212SL	4173	5659	2.16	9.63	1.75	1.62	7.07	7.5	54,9	244,6	44,5	41,1	179,6	3,4
	3 1/8	80	RLP5302SL	4173	5659	2.26	9.73	1.75	1.62	7.17	7.2	57,4	247,1	44,5	41,1	182,1	3,3
RSL8000	2 9/16	55	RLP8203SL	2487	3372	1.71	9.53	2.25	2.00	6.84	8.5	43,4	242,1	57,2	50,8	173,7	3,9
	2 3/8	60	RLP8206SL	3198	4336	1.87	9.67	2.25	2.00	7.00	8.9	47,5	245,6	57,2	50,8	177,8	4,0
	2 9/16	65	RLP8209SL	4122	5589	2.01	9.67	2.25	2.00	7.13	9.0	51,1	245,6	57,2	50,8	181,1	4,1
	2 3/4	70	RLP8212SL	5587	7576	2.16	9.82	2.25	2.00	7.28	9.6	54,9	249,4	57,2	50,8	184,9	4,4
	2 15/16	75	RLP8215SL	5587	7576	2.24	9.90	2.25	2.00	7.36	9.6	56,9	251,5	57,2	50,8	186,9	4,4
	3 1/8	80	RLP8302SL	5587	7576	2.26	9.92	2.25	2.00	7.39	9.3	57,4	252,0	57,2	50,8	187,7	4,2
	3 3/16	-	RLP8303SL	4740	6427	2.26	9.92	2.25	2.00	7.39	9.3	57,4	252,0	57,2	50,8	187,7	4,2

IMPORTANT: RSL-drive units must be ordered separately to operate the RLP-SL-Hexagon Cassettes.

▼ RSL drive unit with interchangeable RSQ square drive cassette



Safety and Performance

- Innovative design that completely encloses all moving parts and minimizes pinch points
- 30-35° rotation angle provides added productivity while avoiding “tool lock on” which is common with some torque wrench designs.

Simplicity

- Simple robust design with just three moving parts for reduced maintenance
- Robust handles are available for both sides and the tops of cassettes to allow for extra maneuverability
- Pull-type square drive release for quickly reversing the square drive for tightening or loosening.

Versatility

- Square Drive Sets available with Interchangeable Hexagon Cassettes
- Power head / square drive combination for flexible use with standard impact quality sockets
- Reaction arm has a simple dial lock for rapid change.

Accuracy

- Constant torque output provides accuracy of $\pm 3\%$ across the full stroke.

Setting New Standards in Safety, Simplicity and Performance



Torque Wrench Options and Accessories

Optional accessories are available for maximum versatility. Please contact your Enerpac representative to help you select the optimum solution for your application.

Page: 33



BSH-Series Sockets

Heavy-Duty Impact Sockets for power driven torquing equipment.

Page: 8



Back-Up Spanners, BUS-Series

To be used to stop the back nut from turning during make up or break out. Two hexagon sizes in one tool.

Page: 9



Torque Wrench Hoses

Use Enerpac THQ700-Series torque wrench hoses with RSL-Series torque wrenches to ensure the integrity of your hydraulic system.

2 meters long, 2 hoses	THQ702T
6 meters long, 2 hoses	THQ706T
12 meters long, 2 hoses	THQ712T



Torque Pumps

Visit enerpac.com for system matched air and electric torque pumps that are ideal for use with hydraulic torque wrenches.

Page: 55

Square Drive Hydraulic Torque Wrenches

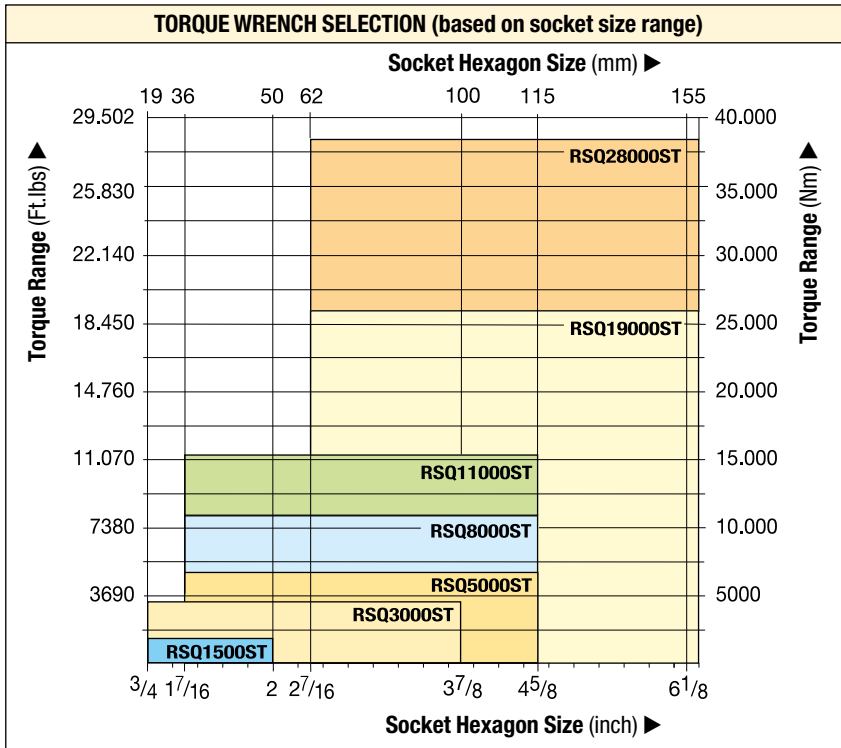

RSL Series



Maximum Torque Output:
1408 - 28.002 Ft.lbs

Maximum Torque Output:
1909 - 37.965 Nm

Square Drive Range:
3/4 - 2 1/2 inch

Maximum Operating Pressure:
690 bar



Select the Right Torque

Choose your Enerpac Torque Wrench using the untightening rule of thumb: Loosening torque equals about 250% of tightening torque.



Safe T™ Torque Lock

The Safe T™ Torque Lock is suitable for all bolted applications from 190 Nm to 15.000 Nm using a heavy duty impact socket.

The patented mechanical locking system creates a hands-free torque wrench solution suitable for Enerpac only square drive tools.

Suitable for RSQ3000, RSQ5000 and RSQ11000.

Page: 10

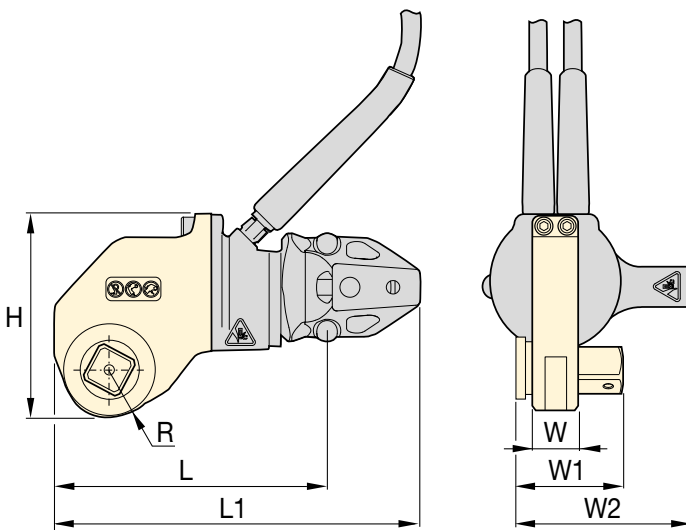

SELECTION CHART

Maximum Torque Output		Square Drive Size (inch)	Square Drive Cassette Model Number ¹⁾	Square Drive Torque Wrench Set Model Number ²⁾	Dimensions (mm)							Weight (kg)		
(Ft.lbs)	(Nm)				W	W1	W2	H	L	L1	R	Drive Unit (without reaction arm)	Reaction Arm	Square Drive Cassette
1408	1909	3/4	RSQ1500	RSQ1500ST	32	58	101	114	160	189	24	1,6	0,5	1,3
3080	4176	1	RSQ3000	RSQ3000ST	38	73	124	141	195	262	32	2,6	1,0	2,4
5303	7190	1 1/2	RSQ5000	RSQ5000ST	45	94	160	163	235	296	39	4,1	1,8	4,1
7862	10.659	1 1/2	RSQ8000	RSQ8000ST	61	105	160	169	241	300	39	4,8	2,0	5,3
11.154	15.123	1 1/2	RSQ11000	RSQ11000ST	64	118	170	201	284	315	48	5,3	3,0	8,4
18.843	25.547	2 1/2	RSQ19000	RSQ19000ST	83	162	265	241	342	482	64	9,1	7,1	13,1
28.002	37.965	2 1/2	RSQ28000	RSQ28000ST	89	166	227	263	358	536	64	10,0	5,0	17,9

¹⁾ When ordering an RSQ Square Drive Cassette, the RSL-Drive Unit must be ordered separately.

²⁾ An RSQ....ST Torque Wrench Set includes RSQ-Square Drive Cassette, RSL-Drive Unit with Hoses and Reaction Arm.

▼ Shown: DSX11000 Square Drive Hydraulic Torque Wrench



Setting Industry-First Safety Standards

Safety and Performance

- High-strength, lightweight aluminium, slimline design suited for complete operator safety
- Fully enclosed drive for maximum safety
- Built-in, work-at-height safety tether connection
- Retained quick release push-button
- Patented, easy-to-use, quick release, retained reaction arm
- Fine tooth ratchet prevents the tool 'locking on'
- High-cycle design with fewer moving parts making it a more efficient tool to operate, maintain or repair
- 35° rotation angle and rapid return stroke for fast operation.

Simplicity

- Includes a robust handle or lifting eye which mounts on either side of the tool for extra maneuverability and safer operation
- Push-button square drive and reaction arm for fast changes and adjustments
- Easily accessible work-at-height connection point.

Accuracy

- Constant torque output provides accuracy of $\pm 3\%$ across the full stroke.

ATEX certified

- All DSX tools are CE - ATEX certified.



Work-at-Height Connection

Built-in, work-at-height safety tether connection.



Fully Retained Reaction Arm

Patented, fully retained reaction arm with easy-to-use quick release, helps prevent injuries when working-at-height.



Secured Square Drive

Retained quick release push-button.



Ergonomic Tool Handle

Robust ergonomic positioning handle comes supplied as standard with every DSX tool. SWH10EA is an eyebolt handle.

Compatible DSX-Series wrenches	Ergonomic Handle (Standard)
DSX1500, 3000, 5000	SWH6A
DSX11000	SWH10A
DSX25000	SWH10EA



Bolting Integrity Software

Enerpac Bolting Integrity Software Solutions play a key role in

implementing and managing an Integrity Program for bolted connections.

The software offers Tool selection, Bolt Load calculations and Tool pressure settings, as well as a combined Application Data Sheet and Joint Completion Report.

Custom Joint information can also be entered.

Square Drive Hydraulic Torque Wrenches

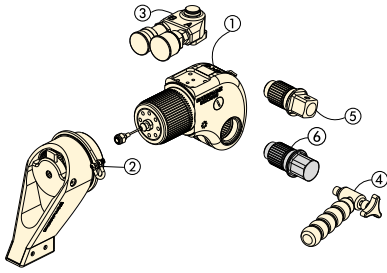

Standard are: ① ② ③ ④ ⑤
Item ⑥ is optional.

- ① Drive Unit
- ② Reaction Arm
- ③ Aluminium Swivel
- ④ Ergonomic Tool Handle
- ⑤ Square Drive
- ⑥ Allen-Key Drive

Select the Right Torque
Choose your Enerpac Torque Wrench using the untightening rule of thumb:
Loosening torque equals about 250% of tightening torque.

DSX Series



Nominal Torque Output:
32.617 Nm

Square Drive Range:
3/4 - 2 1/2 inch

Nose Radius:
24 - 64 mm

Maximum Operating Pressure:
690 bar

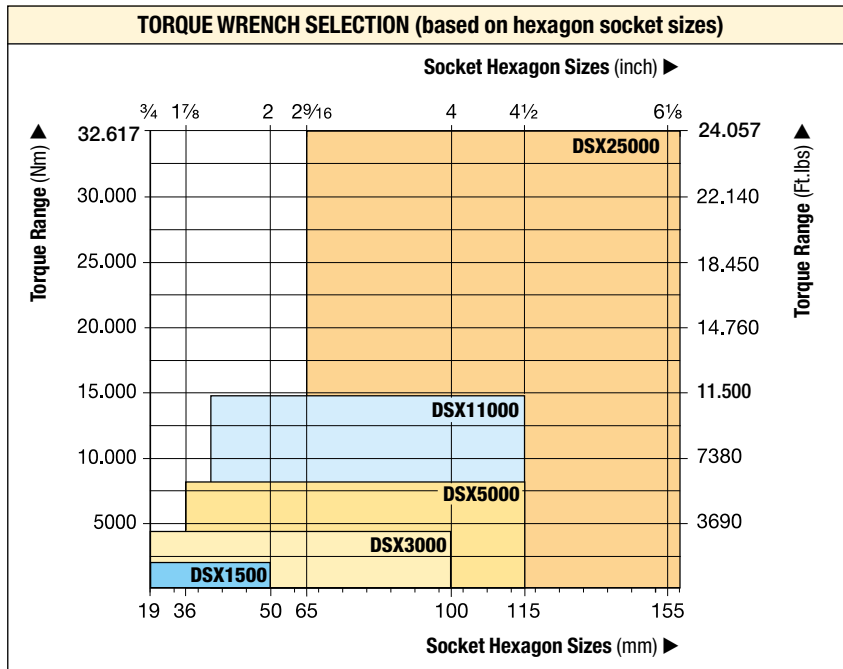

Torque Pump Selection Matrix

For optimum speed and performance see the torque wrench and pump matrix.

Page: 55

▼ The rigid design of the DSX-Series torque wrenches provides durability, reliability and safety.



Use only Heavy Duty Impact Sockets
For power driven torquing equipment, according to ISO2725 and ISO1174; DIN 3129 and DIN 3121 or ASME-B107.2/1995.

Page: 8

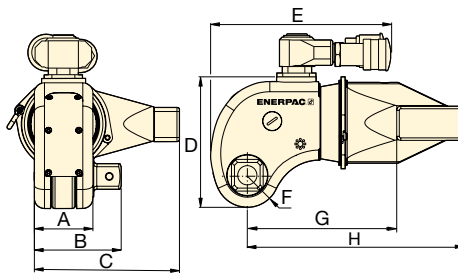

Nominal Torque at 690 bar		Minimum Torque at 69 bar		Square Drive Size (inch)	Torque Wrench Model Number	Dimensions (mm)								Weight (kg)	
(Nm)	(Ft.lbs)	(Nm)	(Ft.lbs)			Model Nr. (included with wrench)	A	B	C	D	E	F	G		H
1913	1411	191	141	3/4	DSX1500-08	DSX1500	44	67	107	96	145	24	114	163	2,2
4383	3233	438	323	1	DSX3000-08	DSX3000	58	86	144	129	171	32	148	215	4,8
7640	5635	764	563	1 1/2	DSX5000-08	DSX5000	69	112	173	148	192	38	180	260	8,1
14.914	11.000	1491	1100	1 1/2	DSX11000-08	DSX11000	87	129	215	181	222	48	227	325	14,4
32.617	24.057	3262	2406	2 1/2	DSX25000-08	DSX25000	117	176	288	244	266	64	281	426	32,5

Maximum Torque Output:

32.617 Nm

Hexagon Size Allen Drive:

1/2 - 2 1/4 inch

Hexagon Size Allen Drive:

14 - 85 mm

For
DSX
Series



Torque Wrench	Optional Allen-Key Drives, Imperial				Optional Allen-Key Drives, Metric			
	Hexagon Size *	Maximum Torque	Model Number	Dim. B1	Hexagon Size *	Maximum Torque	Model Number	Dim. B1
(max. torque)	(inch)	(Ft.Lbs)		(mm)	(mm)	(Nm)		(mm)
 DSX1500 (1411 Ft.lbs) (1913 Nm)	1/2	350	DDA15008	67	14	644	DDA1514	67
	5/8	690	DDA15010	67	17	1152	DDA1517	67
	3/4	1200	DDA15012	67	19	1627	DDA1519	67
	7/8	1411	DDA15014	67	22	1913	DDA1522	67
	1	1411	DDA15100	67	24	1913	DDA1524	67
DSX3000 (3233 Ft.lbs) (4383 Nm)	5/8	690	DDA30010	86	17	1152	DDA3017	86
	3/4	1200	DDA30012	86	19	1627	DDA3019	86
	7/8	1900	DDA30014	86	22	2495	DDA3022	86
	1	2830	DDA30100	86	24	3376	DDA3024	86
	1 1/8	3233	DDA30102	86	27	4383	DDA3027	86
	1 1/4	3233	DDA30104	86	30	4383	DDA3030	86
	-	-	-	86	32	4383	DDA3032	86
DSX5000 (5635 Ft.lbs) (7640 Nm)	5/8	690	DDA50010	112	17	1152	DDA5017	112
	3/4	1200	DDA50012	112	19	1627	DDA5019	112
	7/8	1900	DDA50014	112	22	2495	DDA5022	112
	1	2830	DDA50100	112	24	3376	DDA5024	112
	1 1/8	5325	DDA50102	112	27	4610	DDA5027	112
	1 1/4	5635	DDA50104	112	30	7640	DDA5030	112
	-	-	-	-	32	7640	DDA5032	112
DSX11000 (11.000 Ft.lbs) (14.914 Nm)	1 1/4	5635	DDA110104	129	30	7640	DDA11030	129
	1 3/8	9958	DDA110106	129	32	7640	DDA11032	129
	1 1/2	9958	DDA110108	129	36	10.846	DDA11036	129
	1 5/8	11.000	DDA110110	129	41	14.914	DDA11041	129
	1 3/4	11.000	DDA110112	129	46	14.914	DDA11046	129
DSX25000 (24.057 Ft.lbs) (32.617 Nm)	1 1/2	9958	DDA250104	176	36	10.846	DDA25036	176
	1 5/8	16.433	DDA250106	176	41	16.107	DDA25041	176
	1 3/4	15.200	DDA250112	176	46	22.777	DDA25046	176
	1 7/8	22.777	DDA250114	176	50	29.211	DDA25050	176
	2	24.057	DDA250200	176	55	32.617	DDA25055	176
	2 1/4	24.057	DDA250204	176	60	32.617	DDA25060	176
	-	-	-	-	65	32.617	DDA25065	176
	-	-	-	-	70	32.617	DDA25070	176
	-	-	-	-	75	32.617	DDA25075	176
	-	-	-	-	85	32.617	DDA25085	176

¹⁾ See page 144 for table of hexagon sizes of bolts, nuts and related thread diameters.

Bolting Applications & Portable Machining

Enerpac professional bolting tools provide reliable controlled torque and tension solutions across the industry.

Portable machining products tackle the most demanding in-situ machining applications.

W-Series torque wrench providing accurate and repeatable results

Large numbers of fasteners require precise application of torque to ensure joint integrity is achieved and maintained.

The Enerpac W-Series wrench was selected as it offers simple and reliable operation. The portable Enerpac E-Pulse torque pump was used ideal for high volume fastening applications where weight is a critical factor.



Safe, reliable, and repeatable tensioning with compact HydraMax® Tensioners to complete joint integrity

With their compact fit and high load generation, and the flexibility to work with all standard flanges, the Enerpac HM-Series HydraMax® tensioners can be used in almost every industry and in many different applications.

Portable Machining

Mirage® portable machining products tackle the most demanding in-situ machining applications. By replicating machine shop tolerances in-situ, customers can reliably get the job done faster, safer and smarter. See pages 128-129 for more information.

Oil & Gas: Pipeline repair under pressure; Wellhead high-pressure drilling; Raised, RTJ, compact flanges and hubs; Flange stud removal; Re-thread damaged holes.

Power Generation: Pipe cutting and weld preparation; Wind turbine blade and tower milling; Turbine casing split line repairs; Subsea cutting and decommissioning.



▼ HMT-Drive Units with interchangeable HLP-Low Profile Cassette and HSQ-Square Drive Cassette



The HMT-Series is a range of fast, durable and efficient modular hydraulic torque wrenches, enabling you to tackle almost any bolting application. Interchange cassettes with ease, switching the HLP low profile hexagon cassette with the HSQ square drive whenever your application demands.

As an added benefit, tools and cassettes are interchangeable with many other well-known brands, allowing you the freedom to use the tools at your disposal whilst reducing the cost of upgrading your legacy torque wrench inventory to high quality Enerpac equipment.

The tool itself has been carefully designed and manufactured, utilising superior alloys and surface treatments to make it lightweight, up to 25% faster and more than twice as durable as other tools in the same class.

Safety and Performance

- Supplied with an ergonomic tool safety handle as standard
- The HMT Modular Torque/Tool is also supplied with a link pin retainer as standard.

Versatility

- Interchangeable with other manufacturers
- HMT is able to solve all of your bolting challenges quickly and safely, with one or more attachment options, making it suitable for any application

Simplicity

- The HMT is part of a modular system which is made up of a single power head and one attachment; the HMT Drive Unit and HLP Hexagon cassette or HSQ Square Drive Cassette

Accuracy

- Constant torque output provides accuracy of $\pm 3\%$ across the full stroke.

Modular, Durable, Fast and Efficient Torque for Low Profile and Square Drive Applications



Bolting Integrity Software

The software offers Tool selection, Bolt Load calculations and Tool pressure settings, as well as, a combined Application Data Sheet and Joint Completion Report. Custom Joint information can also be entered.

Page: 142



Back-Up Spanners

To be used to stop the back nut from turning during make up or break out. Two hexagon sizes in one tool.

Page: 9



Torque Pumps

Visit enerpac.com for system matched air and electric torque pumps that are ideal for use with hydraulic torque wrenches.

Page: 55



Torque Wrench Hoses

Use Enerpac THQ700 Series hoses with HMT-Series torque wrenches to ensure the integrity of your hydraulic system.

Page: 100

Drive Units for Hexagon & Square Drive Cassettes



One Drive, Two Tools

One HMT-Hydraulic Torque Wrench fits HLP-Low Profile or HSQ Square Drive cassette.

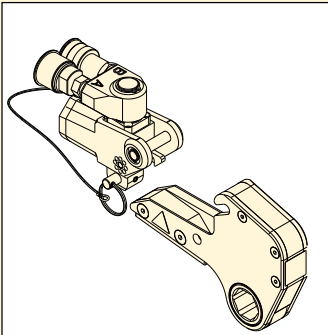

HMT...HLP

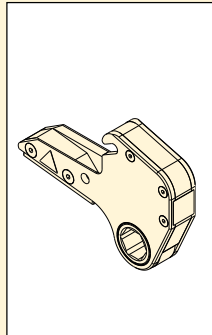

HLP

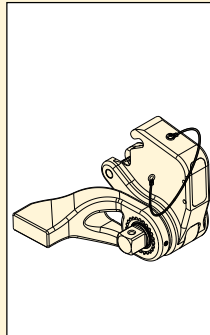

HSQ

HMT Series



Maximum Torque at 10.000 psi:

1541 - 13.489 Ft.lbs

Maximum Torque at 690 bar:

2089 - 18.289 Nm

Hexagon Range:

1 1/16" - 4 5/8" / 26 - 115 mm

Maximum Operating Pressure:

690 bar / 10.000 psi

HMT-Series, Torque Wrench Options and Accessories

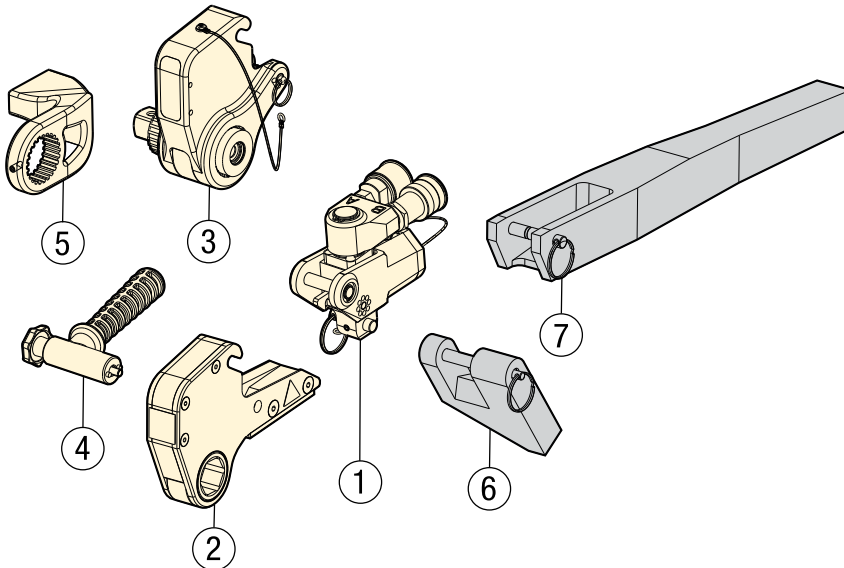

- ① HMT: Drive Unit
- ② HLP: Hexagon Cassette (page 44-45)
- ③ HSQ: Square Drive Cassette (page 46-47)
- ④ SWH: Ergonomic Tool Handle (page 47)
- ⑤ Reaction Arm for HSQ
- ⑥ HRP: Reaction Paddle (page 44)
- ⑦ HTE: Extended Reaction Arm (page 44)

Optional Parts (for HMT with HLP only)



Select the Right Torque

Choose your Enerpac Torque Wrench using the untightening rule of thumb: Loosening torque equals about 250% of tightening torque.



HLP Low Profile Cassettes

For the metric and imperial Low Profile hexagon cassettes see:

Page: 44



HSQ Square Drive Cassettes

For the metric and imperial Square Drive Cassettes see:

Page: 46

SELECTION CHART DRIVE UNITS FOR HEXAGON & SQUARE DRIVE CASSETTES

Maximum Torque Output at 690 bar		Minimum Torque Output at 69 bar		Drive Unit Model Number 	Dimensions (inch)				Dimensions (mm)			
(Ft.lbs)	(Nm)	(Ft.lbs)	(Nm)		A	B	C	(lbs)	A	B	C	(kg)
1541	2089	154	209	HMT1500	4.3	4.1	2.0	2.20	108	104	49	1,0
3750	5084	375	508	HMT3500	5.7	5.2	2.6	3.97	146	132	66	1,8
7562	10.252	756	1025	HMT7500	7.1	6.4	3.2	7.05	180	163	82	3,2
13.489	18.289	1349	1829	HMT13000*	8.5	7.4	3.9	4.40	216	187	98	9,7

* Note: HMT13000 only available for HLP-low profile hexagon cassettes.

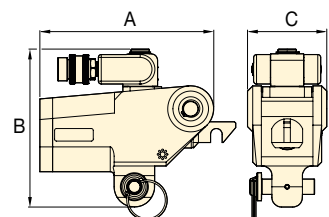

Hexagon Cassettes for HMT Drive Units

ENERPAC

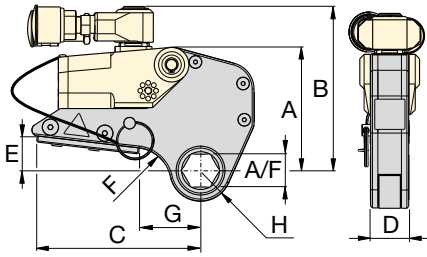

Hexagon Range:
1 1/16 - 4 5/8 inch

Hexagon Range:
26 - 115 mm

Maximum Operating Pressure:
690 bar / 10.000 psi

HLP Series



▼ **SELECTION CHART**

IMPORTANT: HMT-drive units must be ordered separately to operate the HLP-Hexagon Cassettes.

Drive Unit Model Number	Hexagon Size A/F		Hexagon Cassette Model Number	Maximum Torque		Dimensions (inch)										⚖️ (lbs)	Dimensions (mm)								⚖️ (kg)																
	(inch)	(mm)		(Ft.lbs)	(Nm)	A	B	C	D	E	F	G	H	A	B		C	D	E	F	G	H																			
HMT1500	1 1/16	26	HLP1101	1541	2089	4.48	5.32	5.35	1.2	1.13	1.18	2.01	1.00	3.53	114	135	136	31,5	29	30	51	25	1,6																		
	1 1/8	-	HLP1102	1541	2089	4.48	5.32	5.35	1.2	1.13	1.18	2.01	1.00	3.53	114	135	136	31,5	29	30	51	25	1,6																		
	1 3/16	30	HLP1103	1541	2089	4.48	5.32	5.35	1.2	1.13	1.18	2.01	1.00	3.53	114	135	136	31,5	29	30	51	25	1,6																		
	1 1/4	32	HLP1104	1541	2089	4.48	5.32	5.35	1.2	1.13	0.95	2.01	1.08	3.53	114	135	136	31,5	29	24	51	27	1,6																		
	1 5/16	33	HLP1105	1541	2089	4.48	5.32	5.35	1.2	1.13	0.95	2.01	1.08	3.53	114	135	136	31,5	29	24	51	27	1,6																		
	1 3/8	35	HLP1106	1541	2089	4.48	5.32	5.35	1.2	1.13	0.55	1.89	1.19	3.53	114	135	136	31,5	29	14	48	30	1,6																		
	1 1/2	36	HLP1107	1541	2089	4.48	5.32	5.35	1.2	1.13	0.55	1.89	1.19	3.53	114	135	136	31,5	29	14	48	30	1,6																		
	1 5/8	38	HLP1108	1541	2089	4.48	5.32	5.35	1.2	1.13	0.55	2.01	1.30	3.53	114	135	136	31,5	29	14	51	33	1,6																		
	1 3/4	-	HLP1109	1541	2089	4.48	5.32	5.35	1.2	1.13	0.55	2.01	1.30	3.53	114	135	136	31,5	29	14	51	33	1,6																		
	1 7/8	41	HLP1110	1541	2089	4.48	5.32	5.35	1.2	1.13	0.55	2.01	1.30	3.53	114	135	136	31,5	29	14	51	33	1,6																		
	2	-	HLP1111	1541	2089	4.48	5.32	5.35	1.2	1.13	0.55	2.01	1.30	3.53	114	135	136	31,5	29	14	51	33	1,6																		
	2 1/16	-	HLP1112	1541	2089	4.48	5.32	5.35	1.2	1.13	0.55	2.01	1.38	3.53	114	135	136	31,5	29	14	51	35	1,6																		
	2 1/8	46	HLP1113	1541	2089	4.48	5.32	5.35	1.2	1.13	0.55	2.01	1.38	3.53	114	135	136	31,5	29	14	51	35	1,6																		
	2 1/4	-	HLP1114	1541	2089	4.48	5.32	5.35	1.2	1.13	0.55	2.36	1.52	3.53	114	135	136	31,5	29	14	60	39	1,6																		
	2 3/8	-	HLP1115	1541	2089	4.48	5.32	5.35	1.2	1.13	0.55	2.36	1.52	3.53	114	135	136	31,5	29	14	60	39	1,6																		
	2 1/2	50	HLP1200	1541	2089	4.48	5.32	5.35	1.2	1.13	0.55	2.36	1.52	3.75	114	135	136	31,5	29	14	60	39	1,7																		
	2 3/4	-	HLP1201	1541	2089	4.48	5.32	5.35	1.2	1.13	0.55	2.36	1.52	3.75	114	135	136	31,5	29	14	60	39	1,7																		
	2 5/8	-	HLP1202	1541	2089	4.48	5.32	5.35	1.2	1.13	0.55	2.36	1.65	3.75	114	135	136	31,5	29	14	60	42	1,7																		
	2 7/8	55	HLP1203	1541	2089	4.48	5.32	5.35	1.2	1.13	0.55	2.36	1.65	3.75	114	135	136	31,5	29	14	60	42	1,7																		
	3	-	HLP1204	1541	2089	4.48	5.32	5.35	1.2	1.13	0.55	2.36	1.65	3.75	114	135	136	31,5	29	14	60	42	1,7																		
	3 1/16	-	HLP1205	1541	2089	4.48	5.32	5.35	1.2	1.13	0.55	2.36	1.65	3.75	114	135	136	31,5	29	14	60	42	1,7																		
	3 1/8	60	HLP1206	1541	2089	4.48	5.32	5.35	1.2	1.13	0.55	2.36	1.71	3.75	114	135	136	31,5	29	14	60	44	1,7																		
3 1/4	-	HLP1207	1541	2089	4.48	5.32	5.35	1.2	1.13	0.55	2.36	1.71	3.75	114	135	136	31,5	29	14	60	44	1,7																			
HMT3500	1 3/8	35	HLP3106	3750	5084	6.02	6.57	7.24	1.7	1.59	1.89	3.09	1.30	8.60	153	167	184	42,0	41	48	79	33	3,9																		
	1 1/2	36	HLP3107	3750	5084	6.02	6.57	7.24	1.7	1.59	1.89	3.09	1.30	8.60	153	167	184	42,0	41	48	79	33	3,9																		
	1 3/4	38	HLP3108	3750	5084	6.02	6.57	7.24	1.7	1.59	1.81	3.16	1.42	8.60	153	167	184	42,0	41	46	80	36	3,9																		
	1 7/8	-	HLP3109	3750	5084	6.02	6.57	7.24	1.7	1.59	1.81	3.16	1.42	8.60	153	167	184	42,0	41	46	80	36	3,9																		
	2	41	HLP3110	3750	5084	6.02	6.57	7.24	1.7	1.59	1.81	3.16	1.42	8.60	153	167	184	42,0	41	46	80	36	3,9																		
	2 1/16	-	HLP3111	3750	5084	6.02	6.57	7.24	1.7	1.59	1.81	3.16	1.42	8.60	153	167	184	42,0	41	46	80	36	3,9																		
	2 1/8	-	HLP3112	3750	5084	6.02	6.57	7.24	1.7	1.59	1.58	3.08	1.52	8.60	153	167	184	42,0	41	40	78	39	3,9																		
	2 1/4	46	HLP3113	3750	5084	6.02	6.57	7.24	1.7	1.59	1.58	3.08	1.52	8.60	153	167	184	42,0	41	40	78	39	3,9																		
	2 3/8	-	HLP3114	3750	5084	6.02	6.57	7.24	1.7	1.59	1.42	3.05	1.63	8.60	153	167	184	42,0	41	36	77	41	3,9																		
	2 1/2	-	HLP3115	3750	5084	6.02	6.57	7.24	1.7	1.59	1.42	3.05	1.63	8.60	153	167	184	42,0	41	36	77	41	3,9																		
	2 5/8	50	HLP3200	3750	5084	6.02	6.57	7.24	1.7	1.59	1.42	3.05	1.63	8.60	153	167	184	42,0	41	36	77	41	3,9																		
	2 3/4	-	HLP3201	3750	5084	6.02	6.57	7.24	1.7	1.59	1.42	3.05	1.63	8.82	153	167	184	42,0	41	36	77	41	4,0																		
	2 7/8	-	HLP3202	3750	5084	6.02	6.57	7.24	1.7	1.59	1.18	2.97	1.74	8.82	153	167	184	42,0	41	30	75	44	4,0																		
	3	55	HLP3203	3750	5084	6.02	6.57	7.24	1.7	1.59	1.18	2.97	1.74	8.82	153	167	184	42,0	41	30	75	44	4,0																		
	3 1/16	-	HLP3204	3750	5084	6.02	6.57	7.24	1.7	1.59	1.18	2.97	1.74	8.82	153	167	184	42,0	41	30	75	44	4,0																		
	3 1/8	-	HLP3205	3750	5084	6.02	6.57	7.24	1.7	1.59	0.63	2.68	1.85	9.04	153	167	184	42,0	41	16	68	47	4,1																		
	3 1/4	60	HLP3206	3750	5084	6.02	6.57	7.24	1.7	1.59	0.63	2.68	1.85	9.04	153	167	184	42,0	41	16	68	47	4,1																		
	3 3/8	-	HLP3207	3750	5084	6.02	6.57	7.24	1.7	1.59	0.63	2.80	1.85	9.04	153	167	184	42,0	41	16	71	47	4,1																		
	3 1/2	63	HLP3208	3750	5084	6.02	6.57	7.24	1.7	1.59	0.63	2.80	1.96	9.04	153	167	184	42,0	41	16	71	50	4,1																		
	3 3/4	65	HLP3209	3750	5084	6.02	6.57	7.24	1.7	1.59	0.63	2.80	1.96	9.04	153	167	184	42,0	41	16	71	50	4,1																		
	3 5/8	-	HLP3210	3750	5084	6.02	6.57	7.24	1.7	1.59	0.63	2.80	2.07	9.04	153	167	184	42,0	41	16	71	53	4,1																		
	3 7/8	-	HLP3211	3750	5084	6.02	6.57	7.24	1.7	1.59	0.63	2.80	2.07	9.04	153	167	184	42,0	41	16	71	53	4,1																		
	4	70	HLP3212	3750	5084	6.02	6.57	7.24	1.7	1.59	0.63	2.80	2.07	9.04	153	167	184	42,0	41	16	71	53	4,1																		
	4 1/16	-	HLP3213	3750	5084	6.02	6.57	7.24	1.7	1.59	0.63	2.80	2.07	9.04	153	167	184	42,0	41	16	71	53	4,1																		
	4 1/8	-	HLP3214	3750	5084	6.02	6.57	7.24	1.7	1.59	0.63	2.80	2.07	9.04	153	167	184	42,0	41	16	71	53	4,1																		
	4 1/4	75	HLP3215	3750	5084	6.02	6.57	7.24	1.7	1.59	0.63	2.99	2.19	9.04	153	167	184	42,0	41	16	76	56	4,1																		
	4 3/8	3	-	HLP3300	3750	5084	6.02	6.57	7.24	1.7	1.59	0.63	2.99	2.19	9.04	153	167	184	42,0	41	16	76	56	4,1																	
	4 1/2	3 1/16	-	HLP3301	3750	5084	6.02	6.57	7.24	1.7	1.59	0.63	2.99	2.19	9.04	153	167	184	42,0	41	16</																				

Hexagon Cassettes for HMT Drive Units

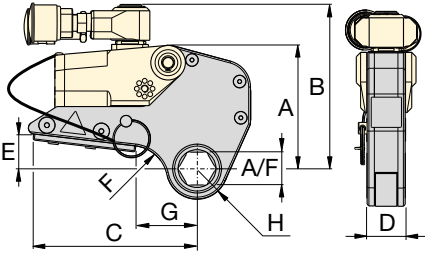

Hexagon Range:
1 1/16 - 4 5/8 inch

Hexagon Range:
26 - 115 mm

Maximum Operating Pressure:
690 bar / 10.000 psi

**HLP
Series**



▼ SELECTION CHART

IMPORTANT: HMT-drive units must be ordered separately to operate the HLP-Hexagon Cassettes.

Drive Unit Model Number	Hexagon Size A/F		Hexagon Cassette Model Number	Maximum Torque		Dimensions (inch)								⚖️ (lbs)	Dimensions (mm)								⚖️ (kg)	
	(inch)	(mm)		(Ft.lbs)	(Nm)	A	B	C	D	E	F	G	H		A	B	C	D	E	F	G	H		
HMT7500	2 3/16	55	HLP7203	7562	10.252	7.60	8.01	8.94	2.1	1.81	1.65	3.39	1.91	15.65	193	203	227	52,6	46	42	86	49	7,1	
	2 1/4	-	HLP7204	7562	10.252	7.60	8.01	8.94	2.1	1.81	1.65	3.39	1.91	15.65	193	203	227	52,6	46	42	86	49	7,1	
	2 5/16	-	HLP7205	7562	10.252	7.60	8.01	8.94	2.1	1.81	1.65	3.39	1.91	15.65	193	203	227	52,6	46	42	86	49	7,1	
	2 3/8	60	HLP7206	7562	10.252	7.60	8.01	8.94	2.1	1.81	1.18	3.15	1.99	15.65	193	203	227	52,6	46	30	80	51	7,1	
	2 7/16	62	HLP7207	7562	10.252	7.60	8.01	8.94	2.1	1.81	1.18	3.15	1.99	15.65	193	203	227	52,6	46	30	80	51	7,1	
	2 1/2	63	HLP7208	7562	10.252	7.60	8.01	8.94	2.1	1.81	1.18	3.15	1.99	15.65	193	203	227	52,6	46	30	80	51	7,1	
	2 9/16	65	HLP7209	7562	10.252	7.60	8.01	8.94	2.1	1.81	0.87	3.15	2.07	15.65	193	203	227	52,6	46	22	80	53	7,1	
	2 5/8	-	HLP7210	7562	10.252	7.60	8.01	8.94	2.1	1.81	0.79	3.15	2.19	15.65	193	203	227	52,6	46	20	80	56	7,1	
	2 1 1/16	-	HLP7211	7562	10.252	7.60	8.01	8.94	2.1	1.81	0.79	3.15	2.19	15.65	193	203	227	52,6	46	20	80	56	7,1	
	2 3/4	70	HLP7212	7562	10.252	7.60	8.01	8.94	2.1	1.81	0.79	3.15	2.19	17.42	193	203	227	52,6	46	20	80	56	7,9	
	2 13/16	-	HLP7213	7562	10.252	7.60	8.01	8.94	2.1	1.81	0.79	3.15	2.19	17.42	193	203	227	52,6	46	20	80	56	7,9	
	2 7/8	-	HLP7214	7562	10.252	7.60	8.01	8.94	2.1	1.81	0.79	3.15	2.19	17.42	193	203	227	52,6	46	20	80	56	7,9	
	2 15/16	75	HLP7215	7562	10.252	7.60	8.01	8.94	2.1	1.81	0.67	3.15	2.26	17.42	193	203	227	52,6	46	17	80	58	7,9	
	3	-	HLP7300	7562	10.252	7.60	8.01	8.94	2.1	1.81	0.67	3.39	2.38	17.42	193	203	227	52,6	46	17	86	61	7,9	
	3 1/16	-	HLP7301	7562	10.252	7.60	8.01	8.94	2.1	1.81	0.67	3.39	2.38	17.42	193	203	227	52,6	46	17	86	61	7,9	
	3 1/8	80	HLP7302	7562	10.252	7.60	8.01	8.94	2.1	1.81	0.67	3.39	2.38	17.42	193	203	227	52,6	46	17	86	61	7,9	
	3 1/4	-	HLP7304	7562	10.252	7.60	8.01	8.94	2.1	1.81	0.67	3.39	2.52	17.42	193	203	227	52,6	46	17	86	64	7,9	
	-	85	HLP7085M	7562	10.252	7.60	8.01	8.94	2.1	1.81	0.67	3.39	2.52	17.42	193	203	227	52,6	46	17	86	64	7,9	
	3 5/8	-	HLP7306	7562	10.252	7.60	8.01	8.94	2.1	1.81	0.67	3.39	2.52	17.42	193	203	227	52,6	46	17	86	64	7,9	
	3 7/16	-	HLP7307	7562	10.252	7.60	8.01	8.94	2.1	1.81	0.67	3.50	2.52	17.64	193	203	227	52,6	46	17	89	64	8,0	
	3 1/2	-	HLP7308	7562	10.252	7.60	8.01	8.94	2.1	1.81	0.67	3.50	2.64	17.64	193	203	227	52,6	46	17	89	67	8,0	
	-	90	HLP7090M	7562	10.252	7.60	8.01	8.94	2.1	1.81	0.67	3.74	2.64	17.64	193	203	227	52,6	46	17	95	67	8,0	
	3 9/16	-	HLP7309	7562	10.252	7.60	8.01	8.94	2.1	1.81	0.67	3.74	2.78	17.64	193	203	227	52,6	46	17	95	71	8,0	
	3 3/4	95	HLP7312	7562	10.252	7.60	8.01	8.94	2.1	1.81	0.67	3.74	2.89	18.08	193	203	227	52,6	46	17	95	71	8,2	
	3 5/8	-	HLP7314	7562	10.252	7.60	8.01	8.94	2.1	1.81	0.67	3.74	2.89	18.08	193	203	227	52,6	46	17	95	74	8,2	
	3 15/16	100	HLP7315	7562	10.252	7.60	8.01	8.94	2.1	1.81	0.67	3.74	2.89	18.08	193	203	227	52,6	46	17	95	74	8,2	
	HMT13000	2 7/16	62	HLP13207	13.489	18.289	8.03	9.53	10.87	2.50	2.25	2.95	4.69	2.28	24.3	204	242	276	63,4	57	75	119	58,0	11,0
		2 1/2	63	HLP13208	13.489	18.289	8.03	9.53	10.87	2.50	2.25	2.95	4.69	2.28	24.3	204	242	276	63,4	57	75	119	58,0	11,0
		2 9/16	65	HLP13209	13.489	18.289	8.03	9.53	10.87	2.50	2.25	2.95	4.69	2.28	24.3	204	242	276	63,4	57	75	119	58,0	11,0
		2 5/8	67	HLP13210	13.489	18.289	8.03	9.53	10.87	2.50	2.25	2.95	4.69	2.28	24.3	204	242	276	63,4	57	75	119	58,0	11,0
2 1 1/16		68	HLP13211	13.489	18.289	8.03	9.53	10.87	2.50	2.25	2.95	4.69	2.28	24.3	204	242	276	63,4	57	75	119	58,0	11,0	
2 3/4		70	HLP13212	13.489	18.289	8.03	9.53	10.87	2.50	2.25	2.95	4.69	2.28	24.3	204	242	276	63,4	57	75	119	58,0	11,0	
2 13/16		71	HLP13213	13.489	18.289	8.03	9.53	10.87	2.50	2.25	2.95	4.69	2.28	24.3	204	242	276	63,4	57	75	119	58,0	11,0	
2 7/8		73	HLP13214	13.489	18.289	8.03	9.53	10.87	2.50	2.25	2.95	4.69	2.28	24.3	204	242	276	63,4	57	75	119	58,0	11,0	
2 15/16		75	HLP13215	13.489	18.289	8.03	9.53	10.87	2.50	2.25	2.76	4.69	2.40	24.3	204	242	276	63,4	57	70	119	61,0	11,0	
3		77	HLP13300	13.489	18.289	8.03	9.53	10.87	2.50	2.25	2.76	4.88	2.56	24.3	204	242	276	63,4	57	70	124	65,0	11,0	
3 1/16		78	HLP13301	13.489	18.289	8.03	9.53	10.87	2.50	2.25	2.76	4.88	2.56	24.3	204	242	276	63,4	57	70	124	65,0	11,0	
3 1/8		80	HLP13302	13.489	18.289	8.03	9.53	10.87	2.50	2.25	2.76	4.88	2.56	24.3	204	242	276	63,4	57	70	124	65,0	11,0	
3 3/16		81	HLP13303	13.489	18.289	8.03	9.53	10.87	2.50	2.25	2.76	4.88	2.58	24.3	204	242	276	63,4	57	70	124	65,5	11,0	
3 1/4		83	HLP13304	13.489	18.289	8.03	9.53	10.87	2.50	2.25	2.76	4.88	2.58	24.3	204	242	276	63,4	57	70	124	65,5	11,0	
3 5/16		84	HLP13305	13.489	18.289	8.03	9.53	10.87	2.50	2.25	2.76	4.88	2.58	24.3	204	242	276	63,4	57	70	124	65,5	11,0	
-		85	HLP13085M	13.489	18.289	8.03	9.53	10.87	2.50	2.25	2.76	4.88	2.58	24.3	204	242	276	63,4	57	70	124	65,5	11,0	
3 5/8		86	HLP13306	13.489	18.289	8.03	9.53	10.87	2.50	2.25	2.76	4.88	2.58	24.3	204	242	276	63,4	57	70	124	65,5	11,0	
3 7/16		-	HLP13307	13.489	18.289	8.03	9.53	10.87	2.50	2.25	2.36	4.88	2.76	24.3	204	242	276	63,4	57	60	124	70,0	11,0	
3 1/2		89	HLP13308	13.489	18.289	8.03	9.53	10.87	2.50	2.25	2.36	4.88	2.76	24.3	204	242	276	63,4	57	60	124	70,0	11,0	
-		90	HLP13090M	13.489	18.289	8.03	9.53	10.87	2.50	2.25	2.36	4.88	2.76	26.5	204	242	276	63,4	57	60	124	70,0	12,0	
3 9/16		91	HLP13309	13.489	18.289	8.03	9.53	10.87	2.50	2.25	1.34	4.33	2.91	26.5	204	242	276	63,4	57	34	110	74,0	12,0	
3 5/8		92	HLP13310	13.489	18.289	8.03	9.53	10.87	2.50	2.25	1.34	4.33	2.91	26.5	204	242	276	63,4	57	34	110	74,0	12,0	
3 1 1/16		94	HLP13311	13.489	18.289	8.03	9.53	10.87	2.50	2.25	1.34	4.33	2.91	26.5	204	242	276	63,4	57	34	110	74,0	12,0	
3 3/4		95	HLP13312	13.489	18.289	8.03	9.53	10.87	2.50	2.25	1.34	4.33	2.91	26.5	204	242	276	63,4	57	34	110	74,0	12,0	
3 13/16		97	HLP13313	13.489	18.289	8.03	9.53	10.87	2.50	2.25	1.73	4.69	2.95	26.5	204	242	276	63,4	57	44	119	75,0	12,0	
3 7/8		99	HLP13314	13.489	18.289	8.03	9.53	10.87	2.50	2.25	1.73	4.69	2.95	26.5	204	242	276	63,4	57	44	119	75,0	12,0	
3 15/16		100	HLP13315	13.489	18.289	8.03	9.53	10.87	2.50	2.25	1.73	4.69	2.95	26.5	204	242	276	63,4	57	44	119	75,0	12,0	
4		102	HLP13400	13.489	18.289	8.03	9.53	10.87	2.50	2.25	1.73	4.88	3.11	26.5	204	242	276	63,4	57	44	124	79,0	12,0	
4 1/16		-	HLP13401	13.489	18.289	8.03	9.53	10.87	2.50	2.25	1.73	4.88	3.11	26.5	204	242	276	63,4	57	44	124	79,0	12,0	
4 1/8		105	HLP13402	13.489	18.289	8.03	9.53	10.87	2.50	2.25	1.73	4.88	3.11	26.5	204	242	276	63,4	57	44	124	79,0	12,0	
4 3/16	-																							

▼ HMT drive unit with HSQ square drive cassette



Modular, Durable, Fast and Efficient Torque for Low Profile and Square Drive Applications

Safety and Performance

- Innovative design that completely encloses all moving parts and minimizes pinch points
- Supplied reaction arm as standard
- Fully adjustable 360 degree in-line reaction arm
- Fine tooth ratchet prevents locking-on

Simplicity

- Simple robust design with just three moving parts for reduced maintenance
- Push button, quick release, reversible square drive

Versatility

- The reaction arm, positioned around the square drive instead of the back of the drive unit, provides you with the possibility to turn the drive unit away from an obstacle

Accuracy

- Constant torque output provides accuracy of $\pm 3\%$ across the full stroke.



Torque Wrench Options and Accessories

Optional accessories are available for maximum versatility. Please contact your Enerpac representative to help you select the optimum solution for your application.

Page: 43



Ergonomic Tool Handle

Robust ergonomic positioning handle comes standard with every HMT Drive Unit.

Compatible HMT-Series drive units	Ergonomic Handle (Standard)
HMT1500, 3500, 7500	SWH6A
HMT13000	SWH10A



BUS-Series, Back-Up Spanners

To be used to stop the back nut from turning during make up or break out. Two hexagon sizes in one tool.

Page: 9



Torque Wrench Hoses

Use Enerpac THQ700 Series hoses with HMT-Series torque wrenches to ensure the integrity of your hydraulic system.

Page: 100

HSQ, Square Drive Hydraulic Torque Wrenches



Bolting Integrity Software

Visit enerpac.com to access our free on-line bolting software application. A comprehensive free online software solution for Bolted Joint Integrity.

Integral databases hold data for:

- BS1560, MSS SP44, API 6A and 17D flanged joints
- Common gasket materials and configurations
- Comprehensive range of bolt materials
- Comprehensive range of lubricants

- Enerpac's Controlled Bolting Equipment including: Torque Multipliers, Hydraulic Wrenches and Bolt Tensioning tools.

Custom Joint information can also be entered

The software offers Tool selection, Bolt Load calculations and Tool pressure settings, as well as a combined Application data sheet and Joint completion report.

Page: 142

HSQ Series



Maximum Torque at 10.000 psi:

1541 - 7562 Ft.lbs

Maximum Torque at 690 bar:

2089 - 10.252 Nm

Square Drive Range:

3/4 - 1 1/2 inch

Maximum Operating Pressure:

690 bar / 10.000 psi

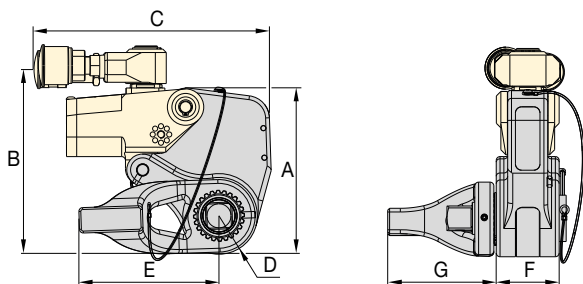
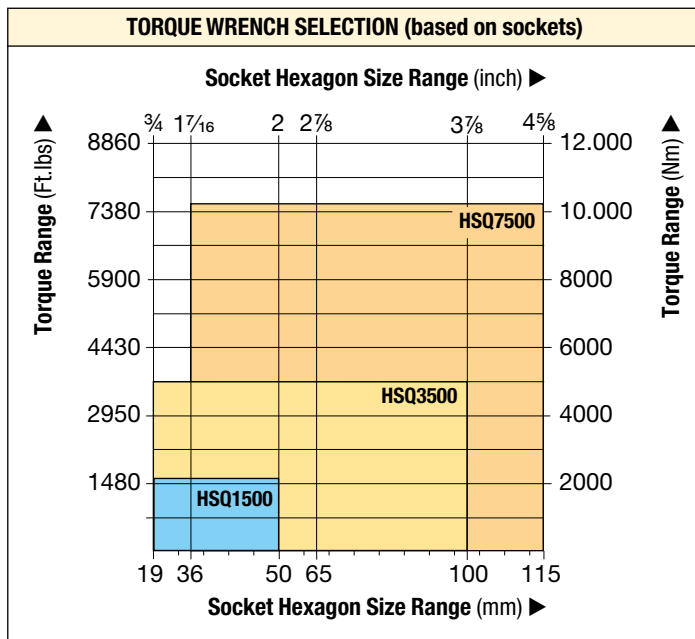

SELECTION CHART

Maximum Torque Output		Square Drive Size (inch)	Square Drive Cassette * Model Number	Dimensions (inch)							Weight (lbs)	Dimensions (mm)							Weight (kg)
(Ft.lbs)	(Nm)			A	B	C	D	E	F	G		A	B	C	D	E	F	G	
1541	2089	3/4	HSQ1500	5.71	6.61	6.85	1.19	2.36	1.95	3.29	8.16	145	168	174	30	60	50	84	3,7
3750	5084	1	HSQ3500	7.54	8.23	7.95	1.52	3.07	2.58	4.35	13.01	192	209	202	39	78	66	111	5,9
7562	10.252	1 1/2	HSQ7500	9.60	10.08	9.25	1.99	4.33	3.23	6.32	25.13	244	256	235	51	110	82	161	11,4

* **IMPORTANT:** HMT-drive units must be ordered separately to operate the HSQ-Square Drive Cassettes.



BSH-Series Sockets

Heavy-Duty Impact Sockets for power driven torquing equipment.

Page: 8



Select the Right Torque

Choose your Enerpac Torque Wrench using the untightening rule of thumb: Loosening torque equals about 250% of tightening torque.



Torque Pumps Selection Matrix

Visit enerpac.com for system matched air and electric torque wrench pumps that are ideal for use with hydraulic torque wrenches.

Page: 55

▼ Shown from left to right: E291, E393, E494



- High-efficiency planetary gear sets achieve high output torque from low input torque
- Operator protected by anti-backlash device
- Torque multiplier accuracy $\pm 5\%$
- Reversible, tighten or loosen bolts
- Reaction bar or reaction plate style
- Angle-of-turn protractor standard on E300-Series models
- Reaction plate models offer increased versatility with reaction point locations
- E300 and E400-Series have replaceable shear drives, providing overload protection of internal power train
- One replacement shear drive is included with each E300 and E400-Series models.



◀ Enerpac Reaction Bar Torque Multiplier E393 used to manually torque bolts up to 4300 Nm.

Accurate, Efficient Torque Multiplication

When accurate make-up or break-out of stubborn fasteners requires high torque



Typical Torque Multiplier Applications

- Locomotives
- Power plants
- Pulp and paper mills
- Refineries
- Chemical plants
- Mining and construction
- Off-road equipment
- Shipyards
- Cranes.



BUS-Series, Back-Up Spanners

To be used to stop the back nut from turning during make up or break out. Two hexagon sizes in one tool.

Page: 9

▼ SELECTION CHART

Torque Multiplier Type	Nominal Torque Output		Model Number
	(Nm)	(Ft.lbs)	
Reaction Bar Multiplier	1020	750	E290PLUS
	1358	1000	E291
	1627	1200	E391
	2983	2200	E392
	4340	3200	E393
Reaction Plate Multiplier	2983	2200	E492
	4339	3200	E493
	6779	5000	E494
	10.846	8000	E495



Manual Torque Multipliers

Enerpac manual torque multipliers provide efficient torque multiplication in wide clearance applications and when external power sources are not available.

Manual torque multipliers are used in most industrial, construction, and equipment maintenance applications. Hydraulic torque wrenches are better suited for tight tolerance, flange and repetitive bolting applications.

Use Reaction Bar Models:

- Where space is limited,
- Where multiple reaction points are available,
- when portability is desirable.

Use Reaction Plate Models:

- Above 4300 Nm output torque,
- On flanges and applications where neighbouring bolt or nut is available to react against
- When extreme reaction forces are generated.

E Series



Nominal Torque Output:

1020 - 10.846 Nm

Torque Ratio:

3:1 - 52:1

Output Ratio Accuracy:

± 5 %



CAUTION!

Never use impact air tools for power driving torque multipliers. Torque multiplier drive train damage will occur.

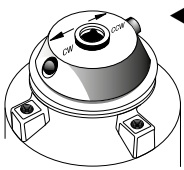

Selector Pawl

Models with anti-backlash protection have directional selector pawls. Set the pawl for clockwise or counter-clockwise rotation.

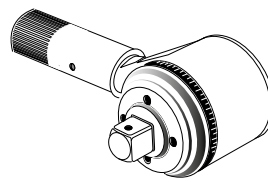

Angle-of-Turn Protractor

E391, E392 and E393 models include an angle-of-turn protractor (scale) to tighten fasteners using a "torque turn" method. Allows accurate measuring a specific number of degrees of rotation.

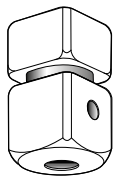

Shearable Square Drive

Provides overload protection on E300- and E400-series multiplier's power train by shearing when the rated capacity of the tool is exceeded. Internal shear pin prevents tool from falling off bolt.



Hydraulic Torque Wrenches

Enerpac offers a complete range of square drive and hexagon cassette torque wrenches.

Page: 1



BSH-Series Sockets

Heavy-Duty Impact Sockets for power driven torquing equipment.

Page: 8

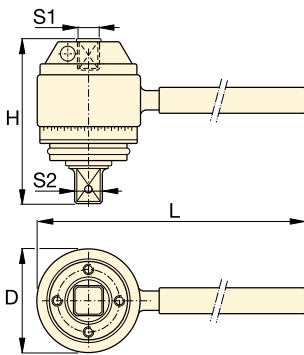

Reaction Bar Type ¹⁾

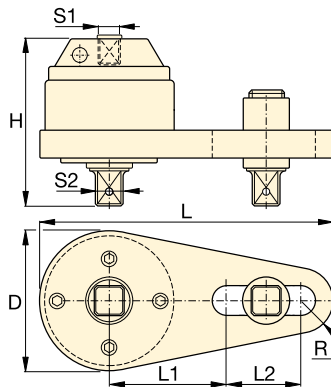

Reaction Plate Type ¹⁾

Input Torque ²⁾	Torque Ratio (estimate)	Input Female Square Drive	Output Male Square Drive		Over-load protection	Anti-Backlash	Dimensions (mm)						Model Number	
			S2 (inch)	Replaceable Shear Drive Model Nr.			D	H	L	L1	L2	R		
339 (Nm) / 250 (Ft.lbs)	3 : 1	1/2 (inch)	3/4 (inch)	-	No	No	71	83	217	-	-	-	1,8 (kg)	E290PLUS
452 (Nm) / 333 (Ft.lbs)	3 : 1	1/2 (inch)	3/4 (inch)	-	No	No	71	83	443	-	-	-	2,5 (kg)	E291
271 (Nm) / 200 (Ft.lbs)	6 : 1	1/2 (inch)	3/4 (inch)	E391SDK	Yes	No	100	102	497	-	-	-	4,1 (kg)	E391
220 (Nm) / 162 (Ft.lbs)	13,6 : 1	1/2 (inch)	1 (inch)	E392SDK	Yes	Yes	103	146	497	-	-	-	6,9 (kg)	E392
235 (Nm) / 173 (Ft.lbs)	18,5 : 1	1/2 (inch)	1 (inch)	E393SDK	Yes	Yes	103	165	497	-	-	-	8,3 (kg)	E393
219 (Nm) / 162 (Ft.lbs)	13,6 : 1	1/2 (inch)	1 (inch)	E392SDK	Yes	Yes	124	140	356	140	124	32	7,8 (kg)	E492
234 (Nm) / 173 (Ft.lbs)	18,5 : 1	1/2 (inch)	1 (inch)	E393SDK	Yes	Yes	124	163	356	140	124	32	8,9 (kg)	E493
256 (Nm) / 189 (Ft.lbs)	26,5 : 1	1/2 (inch)	1 1/2 (inch)	E494SDK	Yes	Yes	143	222	378	178	89	42	15,4 (kg)	E494
209 (Nm) / 154 (Ft.lbs)	52 : 1	1/2 (inch)	1 1/2 (inch)	E495SDK	Yes	Yes	148	273	387	178	89	48	22,8 (kg)	E495

¹⁾ E200 and E400-series do not have an Angle-of-Turn Protractor (scale).

²⁾ User must verify manual torque wrench accuracy prior to use to ensure accurate final output torque.

▼ PTW1000



Productivity

- High speed continuous rotation for constant torque output
- Low friction planetary gearbox design minimizes wear and extends uptime.

Safety

- Ergonomic, low vibration design reduces fatigue and the risk of vibration related injuries for the operator
- Low noise air motor provides quiet, consistent performance for indoor and outdoor applications.

Convenience

- Provided with standard reaction arm; wide assortment of custom arms and accessories are available
- Available with or without Filter-Regulator-Lubricator (FRL)
- Unique calibration certificate provided with each tool.



◀ The PTW1000 makes quick work of this flange maintenance job.

Continuous Rotation Controlled Torque



Calibration Certificate

All PTW-Series tools are CE declared and are shipped complete with a calibration certificate.



FRL120C, Filter-Regulator-Lubricator with air hose

All PTW-Series tools are shipped complete with standard reaction arm, and Filter-Regulator-Lubricator (FRL120C).



MCS-Series, Mobile Calibration System

To check torque accuracy, run calibration tests and create calibration certificates prior to the use of continuous rotation torque tools in various applications while on a job site.

Page: 54

▼ PTW-Series Pneumatic Torque Wrenches are ideal for applications where speed and precision are critical, such as track maintenance.



Pneumatic Torque Wrenches



PTW-Series, Pneumatic Torque Wrenches

Enerpac PTW-Series Pneumatic Torque Wrenches are designed for applications that require speed and control.

The standard package includes a Torque Wrench with a calibration certificate, an FRL (Filter/Regulator/Lubricator), and a 3 m long, 1/2" inch (13 mm) diameter air hose, which connects the FRL to the wrench.

Once the air hoses are connected, the operator simply adjusts the air pressure on

the FRL to achieve the desired torque using the calibration certificate. After this, the tool is ready to go to work! *

The air source used with the PTW system must be regulated and/or limited to 8,3 bar, and must be capable of providing a volume of at least (85 m³/h) at 6,9 bar. A separate 1/2" inch hose (not included) must be used to connect the FRL to the air supply.

* See instruction manual for comprehensive instructions.

PTW Series



Nominal Torque Output:

8135 Nm

Square Drive Range:

3/4 - 1 - 1 1/2 inch

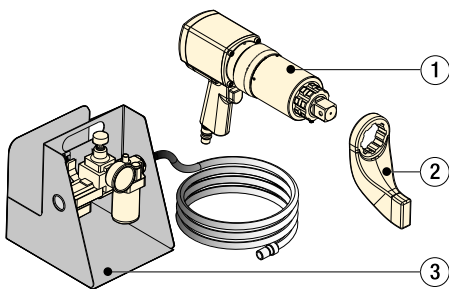

- ① PTW Torque Wrench
- ② Standard Reaction Arm
- ③ FRL120C Filter-Regulator-Lubricator with 3 meters air hose

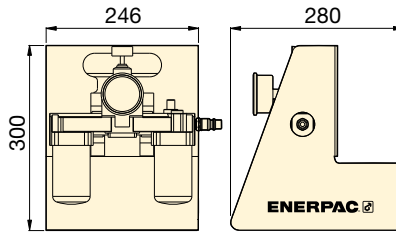
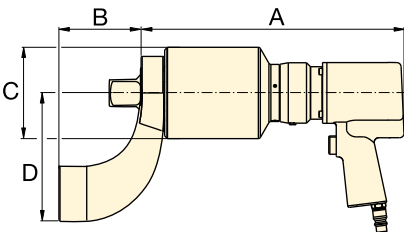

Accessories

Enerpac offers a full line of accessories including a range of reaction arms and drives.

Page: 52



BSH-Series Sockets

Use Heavy-Duty Impact Sockets for power driven torquing equipment.

Page: 8



BUS-Series, Back-Up Spanners

Hands free tool to be used to stop the back nut from turning during make up or break out.

Page: 9

▼ SELECTION CHART

All tools are shipped complete with standard reaction arm and FRL120C.

Minimum Torque		Nominal Torque		Square Drive (inch)	Model Number ¹⁾ (FRL120C included)	Speed (RPM)	Dimensions (mm)				Weight (kg) ²⁾
(Nm)	(Ft.lbs)	(Nm)	(Ft.lbs)				A	B	C	D	
407	300	1356	1000	3/4	PTW1000-75C	12,6	272	83	72	130	7,9
407	300	1356	1000	1	PTW1000C	12,6	272	83	72	130	8,2
678	500	2712	2000	1	PTW2000C	8,0	286	83	79	133	8,8
1220	900	4067	3000	1	PTW3000C	3,1	343	83	95	133	10,4
1763	1300	8135	6000	1 1/2	PTW6000C	2,5	366	114	127	178	17,7

¹⁾ To order without FRL120C, remove "C" suffix from model number (example: **PTW3000**).

²⁾ Weight does not include reaction arm.

Reaction arm weight for PTW1000, PTW2000, PTW3000 is 1,3 kg and for PTW6000 is 3,5 kg.

▼ Shown: Accessories for PTW-Series Torque Wrenches



- Accessories for further extending the application range of pneumatic torque wrenches
- Extended drives increases tool fit in restricted access areas.

▼ PTW-Wrenches are ideal for applications where speed and precision are critical, such as track or wheel maintenance.



PTW-Accessories

Enerpac offers the following accessories to support a wide variety of applications in industries such as mining, power generation and oil & gas. For additional custom accessories not pictured here, please contact Enerpac.



Applications

PTW-Series Pneumatic Wrenches are designed for applications that require speed and control.

Mining

- Track maintenance
- Undercarriage maintenance
- Wheel maintenance
- Shovel maintenance

Power Generation

- Turbine bolts
- Tower segments
- Turbine casings

Oil & Gas

- Pipe flanges
- Valves
- Manway covers
- Pressure vessels



Accessories for PTW-Series Torque Wrenches

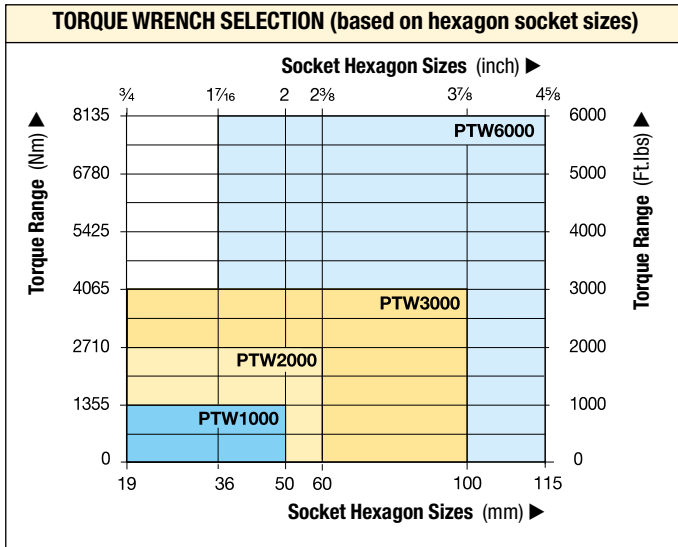

PTW Series



Nominal Torque Output:

8135 Nm

Square Drive Range:

3/4 - 1 - 1 1/2 inch



BSH-Series Sockets

Use Heavy-Duty Impact Sockets for power driven torquing equipment.

Page: **8**

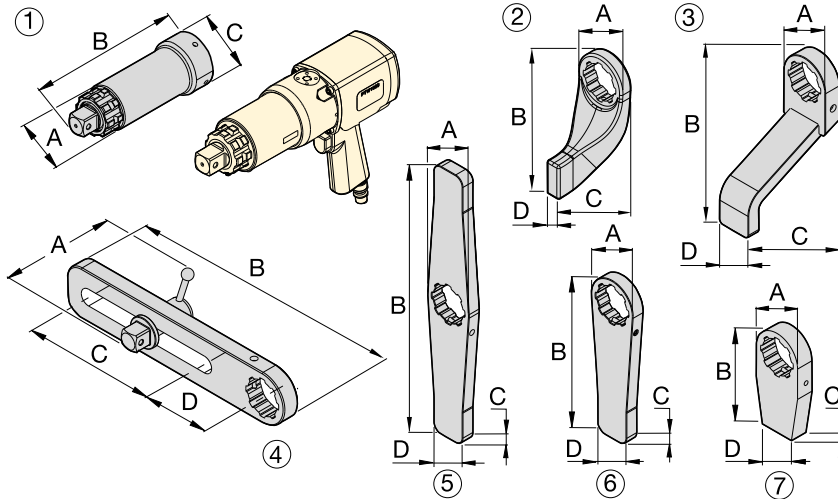

Optional Accessories

For use with PTW1000, 2000, 3000-models

Nr.	Description	Model Nr.	Application	Dimensions (mm)			
				A	B	C	D
1	Extended Drive, 6 inch (152 mm)	ED6TWS	Nose extension, primarily for truck wheel bolts	62	206	73	–
1	Extended Drive, 12 inch (305 mm)	ED12TWS	Nose extension, primarily for truck wheel bolts	62	384	73	–
1	Extended Drive, 18 inch (457 mm)	ED18TWS	Nose extension, primarily for truck wheel bolts	62	511	73	–
2	Standard Reaction Arm	RATWS	Standard arm included with PTW model	76	172	102	21
3	Extended Reaction Arm	ERATWS	Long plate for use with deep well sockets	73	150	202	51
4	Sliding Reaction Arm	SLRATWS	For widely spaced and uneven bolt centers	112	381	203	102
5	Double Straight Reaction Arm	DSATWS	Reduces time to reposition arm *	73	406	19	102
6	Straight Reaction Arm	SRATWS	Long plate for wide spaced reaction points	73	240	19	51
7	Blank Reaction Arm **	BLTWS	Weldable blank for custom applications **	72	151	25	51

For use with PTW6000-models

1	Extended Drive 6 inch (152 mm)	ED6TWL	Nose extension, primarily for truck wheel bolts	84	232	102	–
1	Extended Drive 12 inch (305 mm)	ED12TWL	Nose extension, primarily for truck wheel bolts	84	384	102	–
2	Standard Reaction Arm	RATWL	Standard arm included with PTW model	102	229	146	32
3	Extended Reaction Arm	ERATWL	Long plate for use with deep well sockets	102	254	184	64
4	Sliding Reaction Arm	SLRATWL	For widely spaced and uneven bolt centers	152	419	190	114
5	Double Straight Arm	DSATWL	Reduces time to reposition arm *	102	508	32	57
6	Straight Reaction Arm	SRATWL	Long plate for wide spaced reaction points	102	305	32	57
7	Blank Reaction Arm **	BLTWL	Weldable blank for custom applications **	102	152	32	57

* Time to reposition arm when repeatedly moving from tightening to loosening.

** WARNING: Blank reaction arms must be heat treated to HRc 38-42 prior to use.

▼ MCS7500C, Mobile Calibration System



MCS Series

Measurable Output Torque Range:
200 - 10.000 Nm

Measurable Output Torque Range:
148 - 7378 Ft.lbs

Female Square Drive:
1½ inch



Accuracy

The calibration system is a calibrated instrument qualified in a UKAS certified laboratory. The accuracy of the MCS7500C is calibrated to meet or exceed: 1% of FSD from 2% to 8% of torque range and 1% of reading from 8% to 100% of torque range.

Versatility

- Accurately measures torque output for continuous rotation tools and square drive hydraulic (*) torque wrenches from 200 - 10.000 Nm (148 - 7375 Ft.lbs)
- Adaptable design enables use with a large variety of Enerpac and competitive wrenches
- Internal Li-ion battery pack, external power via 5V DC USB power supply.

Performance

- Certificate Manager feature enables quick and easy creation of calibration certificates
- Tool database feature allows specific wrench data and calibration results to be recorded and saved for future use
- Each MCS comes with a standard ISO17025 calibration certificate.

Ease of Use

- Compact design in carrying facilitates easy transport, allowing calibration to be carried out in the shop, on jobsites, or even in a vehicle
- Integrated digital interface enables torque values to be displayed, saved, printed or transferred to a computer.



Female Reducer Set

The Female Reducer Set consists of two reducers: 1½ x 1 inch and 1½ x ¾ inch. To be ordered separately as MCS7500RS.



Additional Reaction Block and Adaptor

A heavy-duty adjustable reaction block in combination with one of the three adaptors is required to facilitate the use with S, RSQ and DSX-Series Square Drive Wrenches as well as most competitive hydraulic wrenches to maximum 10.000 Nm (7375 Ft.lbs). Drawings of additional reaction block and adaptor are available upon request.

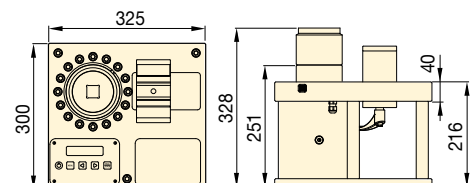































Minimum Measurable Torque Output		Nominal Measurable Torque Output		Female Square Drive	Model Number **	Description	(kg)
(Nm)	(Ft.lbs)	(Nm)	(Ft.lbs)				
200	148	10.000	7375	1½	MCS7500C	MCS with carrying case	40

* Additional Reaction Block and appropriate Adaptor is required with the use of S, RSQ and DSX-Series square drive hydraulic wrenches.

** Not suitable for use with impact tools or low profile torque wrenches.

Optimum Wrench-Torque Pump Combinations

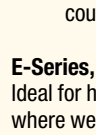
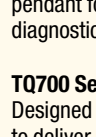
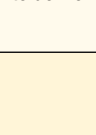
For optimum speed and performance Enerpac recommends the following system set-up with wrench-pump-hose combinations. For other combinations, consult your Enerpac bolting expert or your authorized Enerpac distributor.

		ELECTRIC TORQUE PUMPS					AIR DRIVEN TORQUE PUMPS	
		Cordless XC-Series	E-Pulse® E-Series	TQ-Series	ZU4T-Series	ZE4T-Series ZE5T-Series	LAT-Series	ZA4T-Series
								
		Page: 56	Page: 58	Page: 60	Page: 62	Page: 66	Page: 68	Page: 70
Speed:								
Oil Flow at 700 bar:	0,25 l/min	0,52 l/min	0,5 l/min	1,0 l/min	0,8 - 1,6 l/min	0,4 l/min	1,0 l/min	
Reservoir Capacity:	2,0 litres	3,0 litres	4,0 litres	4,6 - 6,8 litres	4,6 - 39 litres	3,0 litres	4,6 - 6,8 litres	
Duty Cycle:	Intermittent	Heavy-Duty	Standard	Heavy-Duty	Heavy-Duty	Standard	Heavy-Duty	
Weight:								
Work:	Field	Field/Factory	Field/Factory	Field	Factory	Field	Field	
 4	S1500X	Optimal	Optimal	Optimal	Optimal	Optimal	Optimal	
	S3000X							
 12	S6000X	-	Acceptable	Acceptable	Optimal	Optimal	Optimal	
	S11000X							
 26	S25000X	Optimal	Optimal	Optimal	Optimal	Optimal	Optimal	
	W2000X							
 38	W4000X	-	Acceptable	Acceptable	Optimal	Optimal	Optimal	
	W8000X							
 42	W15000X	Optimal	Optimal	Optimal	Optimal	Optimal	Optimal	
	W22000X							
 42	W35000X	-	Acceptable	Acceptable	Optimal	Optimal	Optimal	
	RSL1500							
 42	RSL3000	Optimal	Optimal	Optimal	Optimal	Optimal	Optimal	
	RSL5000							
 42	RSL8000	-	Acceptable	Acceptable	Optimal	Optimal	Optimal	
	RSL11000							
 42	RSL19000	Optimal	Optimal	Optimal	Optimal	Optimal	Optimal	
	RSL28000							
 42	DSX1500	Optimal	Optimal	Optimal	Optimal	Optimal	Optimal	
	DSX3000							
42	DSX5000	-	Acceptable	Acceptable	Optimal	Optimal	Optimal	
	DSX11000							
42	DSX25000	Optimal	Optimal	Optimal	Optimal	Optimal	Optimal	
	HMT1500							
42	HMT3500	Acceptable	Acceptable	Acceptable	Optimal	Optimal	Optimal	
	HMT7500							
42	HMT13000	-	Acceptable	Acceptable	Optimal	Optimal	Optimal	



XC-Series, Portable Cordless Pumps
Ideal for maintenance bolting applications at sites that do not have access to power or where having extension cords or air hoses could cause trip hazards.

E-Series, E-Pulse Portable Torque Pumps
Ideal for high volume fastening applications where weight is critical. Feature an interactive pendant for operation, programming and diagnostics.

TQ700 Series Electric Torque Pumps
Designed for both portability and production, to deliver superior bolting speed.

ZU4T-Series, Electric Torque Pumps
Works well with long extension cords or generator driven electrical power supplies. Available in **Pro** and **Classic** formats.
ZU4T Pro Pumps have an LCD feature to display torque or pressure, selectable torque wrench, and self-diagnostics.
ZU4T Classic Pumps feature an analogue gauge and a basic electrical package to deliver durable, safe and efficient hydraulic power.

ZE-T Series Electric Torque Pumps
Features LCD to display torque or pressure values, and self-diagnostics. With induction motor, making the ZE-Series the coolest and quietest pumps in their class.

LAT-Series, Lightweight Torque Air Pumps
Combines compact design and high productivity for bolting applications in areas hard to access with larger air powered pumps.

ZA4T-Series Air Driven Torque Pumps
This air driven pump is best suited to power medium to large size torque wrenches.

THQ-Series, Torque Wrench Hoses
Use Enerpac THQ-Series twin hoses with all torque wrenches to ensure the integrity of your hydraulic system (see page 100).

▼ XC1502TE



- Ideal for maintenance bolting applications requiring portability and convenience
- Interactive pendant provides visual and vibration feedback of pump operation
- Superior run-time with 5Ah, 28V battery
- 6 metres detachable pendant control
- 100 mm glycerine-filled gauge for easy viewing
- Bladder reservoir allows pump to be used in any position
- High-strength fiberglass reinforced composite housing provides superior durability in demanding job site environments
- Integrated handle and carrying strap for portability.

Portable Battery Pump for Torque Applications



28-Volt Battery

The **XC28V5** 5 Amps battery with Lithium-Ion technology for maximum battery performance.



Battery Charger

1-hour quick charger.

115V battery charger	XC115VC
230V battery charger	XC230VC



Roll Cage

Roll cage accessory option for both XC-TW and XC pump. Please order model number **XCRCTK**.



Torque Wrenches

The following torque wrenches are ideal for use with the XC-Series Cordless Torque Wrench Pumps:

S	W	RSL	DSX	HMT
S1500X	W2000X	RSL1500	DSX1500	HMT1500
S3000X	W4000X	RSL3000	DSX3000	HMT3500
		RSL5000		HMT7500

Larger torque wrenches will work with the pump, battery run time and application speed will be impacted.

- Glycerin-filled gauge
- Trigger lock-off
- Integrated carrying handle
- Impact-resistant composite housing
- 28V, 5 amp/hr lithium-ion battery
- Brushless DC motor
- 2 liter oil reservoir
- Interactive pendant



XC-Series, Cordless Torque Wrench Pumps



Battery-Powered Torque Wrench Pumps

The XC-Series Cordless Torque Wrench pump is ideal for maintenance applications in the PowerGen, Oil & Gas and MRO markets. This portable pump is perfect for remote locations, sites that do not have access to power or where trip hazards are a concern.

The interactive pendant allows the user to set and clear pressure and operate in manual or auto-cycle mode. The pump has an easily accessible user adjustable valve for precise pressure control.

Torque Wrench	Nut A/F (mm)	Stud (mm)	Pressure (bar)	Torque (Nm)	Fasteners torqued
S3000X	60	38	330	2035	32
W2000X	60	38	350	1356	52

XC Series



Reservoir Capacity:
2,0 litres

Flow at Rated Pressure:
0,25 l/min

Motor Size:
0,37 kW

Maximum Operating Pressure:
700 bar

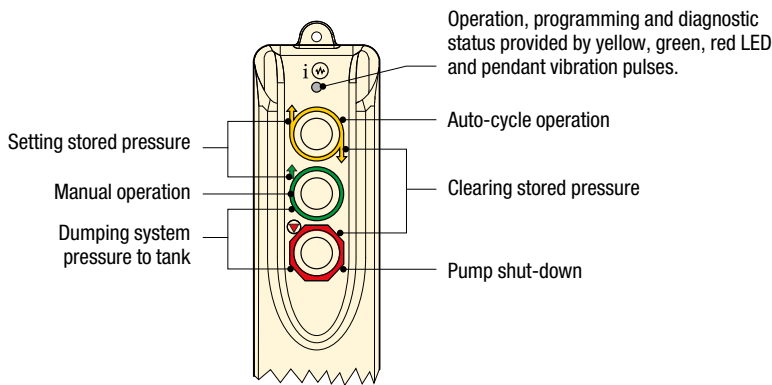

Torque Wrench Hoses

Use Enerpac 700 bar THQ-Series torque wrench hoses with torque wrenches and pumps. See page 100.

2 m long, 2 hoses	THQ702T
6 m long, 2 hoses	THQ706T
12 m long, 2 hoses	THQ712T

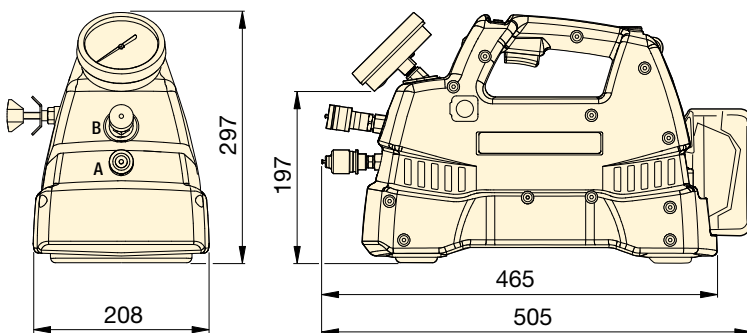

OIL FLOW vs. PRESSURE

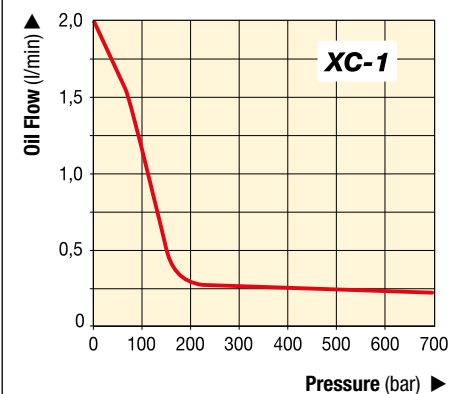

SELECTION CHART

Description	Useable Oil Capacity (litres)	Model Number	Output Flow Rate (l/min)			Included with pump	Weight (kg) ¹⁾
			No Load	140 bar	700 bar		
Cordless Pump Kit	2,0	XC1502TB	2,05	0,49	0,25	2 batteries and 115V charger	12
Cordless Pump Kit	2,0	XC1502TE	2,05	0,49	0,25	2 batteries and 230V charger	12
Cordless Pump	2,0	XC1502T	2,05	0,49	0,25	No batteries or charger	12

¹⁾ Weight includes oil, without battery. battery weight 1,1 kg.

▼ EP3504TE, E-Pulse Torque Wrench Pump



Performance

- Two-stage pump with high by-pass pressure: 1,0 l/min at 200 bar, 0,52 l/min at 700 bar
- Smart controls enable motor to maintain constant power across the pressure range
- 24VDC power regulator minimizes effects of poor power supply
- Six-piston block design provides even flow for smooth operation.

Durability

- Durable aluminium housing
- Integrated heat exchanger minimizes heat buildup
- High-efficiency permanent magnet, direct drive motor enables continuous use and long service life
- Built-in thermal protection
- IP Rating: IP54 on the pump, IP67 on the pendant.

Convenience

- Integrated calibrated pressure gauge
- Interactive pendant with smart controls
- Pendant and cord management system
- Intelligent Auto-Cycle enables press and release actuation to cycle torque wrench until final torque is achieved
- User can set pressure and operate in manual or auto-cycle mode
- Convenient oil fill port, oil level indicator and automatic breather.

Productivity through innovation



Bolting Integrity Software

A comprehensive on-line software solutions for Bolted Joint Integrity. The software offers Tool selection, Bolt Load calculations and Tool pressure settings, as well as, a combined Application Data Sheet and Joint Completion Report. Custom Joint information can also be entered.

Page: 142



Torque Wrenches

The following torque wrenches are ideal for use with the E-Pulse Torque Wrench Pumps:

S	W	RSL	DSX	HMT
S1500X	W2000X	RSL1500	DSX1500	HMT1500
S3000X	W4000X	RSL3000	DSX3000	HMT3500
		RSL5000	DSX5000	HMT7500

Larger torque wrenches will work with the pump, but application speed will be impacted.

Page: 55



Torque Wrench Hoses

Use Enerpac 700 bar THQ-Series torque wrench hoses with torque wrenches and pumps.

2 m long, 2 hoses	THQ702T
6 m long, 2 hoses	THQ706T
12 m long, 2 hoses	THQ712T

Page: 100

E-Pulse®, Electric Torque Wrench Pumps



E-Pulse Torque Wrench Pumps

The Enerpac E-Pulse Electric Torque Wrench Pump, through its innovative design, is ideal for high volume fastening applications where weight is a critical factor. Smart controls enable the motor to maintain constant power providing higher flow than traditional pumps.

The durable aluminum housing, integrated heat exchanger and highly efficient permanent magnet motor minimize heat buildup in the toughest environments. The interactive pendant provides the operator a number of usage options for optimal efficiency. The E-Pulse Torque Wrench Pump is the pinnacle of bolting equipment.

E Series



Reservoir Capacity:
3,0 litres

Flow at Rated Pressure:
0,52 l/min

Motor Size:
0,63 kW

Maximum Operating Pressure:
700 bar

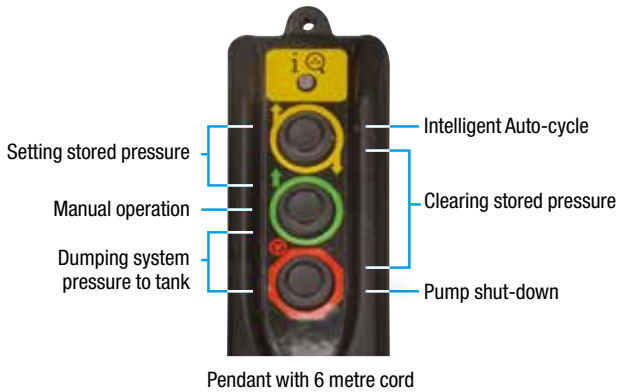

Pendant with 6 metre cord

Interactive Torque Wrench Pendant

- User can set pressure and operate in manual or auto-cycle mode
- Intelligent Auto-Cycle enables press and release actuation to cycle torque wrench until final torque is achieved.

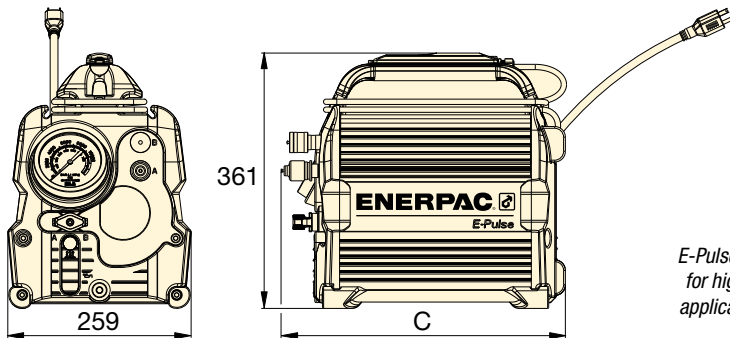
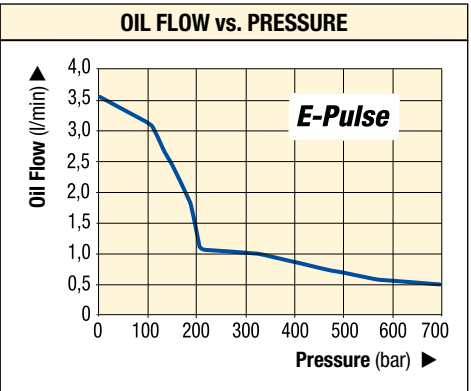

E-Pulse torque pump used for high volume fastening applications where weight is a critical factor. ▶



▼ SELECTION CHART

Number of Wrenches pump can operate	Useable Oil Capacity (litres)	Model Number	Output Flow Rate (l/min)				Motor Voltage (VAC)	Current Draw (Amps)	Plug Type	Sound Level (dBA)	Dimension C (mm)	Weight (kg) ¹⁾
			1 bar	175 bar	350 bar	700 bar						
1	3,0	EP3504TB	3,61	2,13	0,95	0,52	100-120	12	NEMA 5-15	70-85	401	20,4
		EP3504TI	3,61	2,13	0,95	0,52	200-250	7	NEMA 6-15	70-85	401	20,4
		EP3504TE	3,61	2,13	0,95	0,52	200-250	7	Schuko CEE 7/7	70-85	401	20,4
2	3,0	EP3504TB-M *	3,61	2,13	0,95	0,52	100-120	12	NEMA 5-15	70-85	429	21,7
		EP3504TI-M *	3,61	2,13	0,95	0,52	200-250	7	NEMA 6-15	70-85	429	21,7
		EP3504TE-M *	3,61	2,13	0,95	0,52	200-250	7	Schuko CEE 7/7	70-85	429	21,7

* Pump model with multi-port manifold.

¹⁾ with oil

▼ TQ700E



- Optimized flow technology – three stage pump maximizes productivity of the pump and tool while minimizing heat build-up and down time
- Heat exchanger is standard included
- A quiet (<85 dBA), lightweight pump with a compact footprint – easy to move around and through the work site
- Durable roll cage with an ergonomically sized handle and shielded gauge – a pump that is easy to put into position and safe from on site operational hazards
- Maintenance made simple with a brushless motor designed for continuous usage
- Straightforward operation with a simple pressure set and convenient to use 6 m pendant control – immediate productivity for crews operating the pump
- IP55 Rating for Superior Dust and Water Protection
- Transparent gauge overlays in Nm and Ft.lbs for all Enerpac torque wrenches provide a quick torque reference.



The TQ700E and the W-Series wrenches are a productive combination in wind applications.

Lightweight Torque Wrench Pumps



Four Port Manifold

The TQ700 offers an optional four wrench manifold as an accessory factory installed. (Add suffix "M" at the end of the model number.

For example: **TQ700EM**).



Torque Wrench Hoses

Use Enerpac 700 bar THQ-Series torque wrench hoses with torque wrenches and pumps.

2 m long, 2 hoses	THQ702T
6 m long, 2 hoses	THQ706T
12 m long, 2 hoses	THQ712T

Page: 100



Hydraulic Torque Wrenches

Enerpac offers a complete range of square drive and hexagon cassette torque wrenches.

Page: 1



Overlay Kit with Gauge

Available separately for use with TQ-Series: **GT4015Q** includes gauge and torque overlays for all Enerpac torque wrenches.



TQ700 Applications

The TQ700 Series pump is ideal for powering hydraulic wrenches for the Power Generation and Wind Markets.

Bolting speed is more complex than how much flow per minute the pump produces. The key is optimising the flow rate across the entire bolting cycle. With more oil flowing at the right time and at the right volume, you achieve the optimized flow for a hydraulic bolting system.

The result of this optimized flow is more bolts tightened faster and a more productive work team.

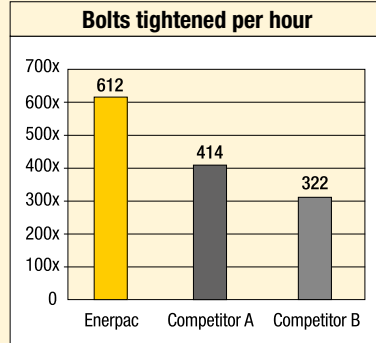

Internal laboratory testing based on standard torquing procedure on a pipe flange with 14, 1 1/2" bolts.

TQ Series



Reservoir Capacity:

4,0 litres

Flow at Rated Pressure:

0,5 l/min

Motor Size:

0,75 kW

Maximum Operating Pressure:

700 bar



Torque Pump Selection Matrix

For optimum speed and performance see the torque pump and hose selection matrix.

Page: 55

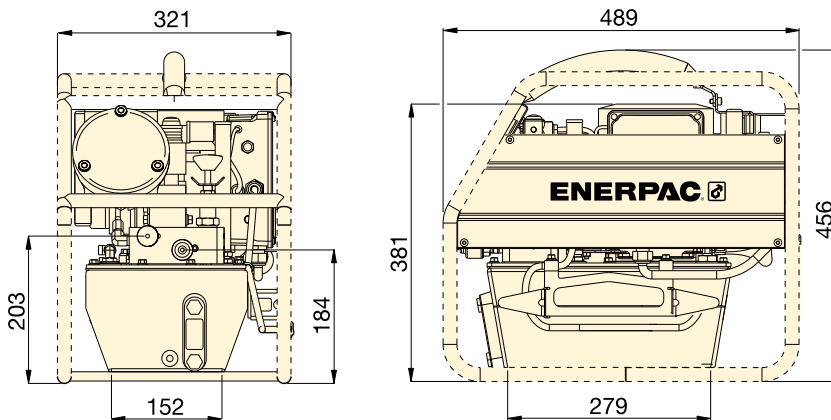

For Use with Torque Wrenches	Pressure Rating (bar)	Model Number ¹⁾	Useable Oil Capacity (litres)	Motor Size (kW)	Motor Electrical Specifications (Volt - Ph - Hz)	Sound Level (dBA)	Weight (kg)
All Series	700	TQ700B	4,0	0,75	115 - 1 - 50/60	82 - 85	31
	700	TQ700E ²⁾	4,0	0,75	230 - 1 - 50	82 - 85	30
	700	TQ700I ³⁾	4,0	0,75	230 - 1 - 60	82 - 85	30

¹⁾ All models meet CE safety requirements and all TÜV requirements.

²⁾ TQ700E with European plug and CE EMC directive compliant.

³⁾ TQ700I with NEMA 6-15 plug.

▼ The TQ700E and the W-Series wrenches are a productive combination.



▼ ZU4204TE-Q (Pro), ZU4204BE-Q (Classic)



Z Tough, Dependable Innovative CLASS



Classic Electrical

Basic electrical package includes mechanical contactor, ON/OFF toggle switch, pendant with electro-mechanical push buttons, 24V transformer timer and operator accessible circuit breaker.

- Features Z-Class high-efficiency pump design; higher oil flow and bypass pressure, cooler running and requires 18% less current draw than comparable pumps
- Powerful 1,25 kW universal electric motor provides high power-to-weight ratio and excellent low-voltage operating characteristics
- High-strength, molded composite shroud protects motor and electrical components, while providing an ergonomic, non-conductive handle for easy transport
- Low-voltage pendant provides additional safety for the operator.

Pro Series pump only

- LCD readout provides pressure display and a number of diagnostic and readout capabilities never before offered on a portable electric pump
- AutoCycle feature provides continuous cycle operation of the torque wrench as long as the advance button is pressed (pump can be used with or without auto cycle feature).



Pro-Series

Back-lit LCD and Pressure Transducer featuring Auto-Cycle Technology.

- Torque wrench model is selectable
- "Auto cycle" setting easily programmable.
- Digital read-out and "Autocycle" setting
- Pump usage information, hour and cycle counts
- Low-voltage warning and recording
- Self-test and diagnostic capabilities
- Information can be displayed in English, French, German, Italian, Spanish and Portuguese
- Pressure transducer is more accurate and durable than analog gauges
- Easy-viewing variable rate display
- Display pressure in bar, MPa or psi.



◀ Any brand of hydraulic torque wrench can be powered by the portable ZU4T-Series torque pump.

ZU4T-Series, Torque Pumps



Z-Class – A Pump For Every Application

Patented Z-Class pump technology provides high bypass pressures for increased productivity – important in applications using long hose runs and high pressure-drop circuits, like heavy lifting or certain double-acting tools.

Enerpac ZU4T-Series pumps are built to power small to large torque wrenches. Choosing the right ZU4T-Series torque wrench pump for your application is easy.

Classic Electric Torque Wrench Pump

- The Classic has traditional electro-mechanical components (transformers, relays and switches) in place of solid-state electronics. The Classic delivers durable, safe and efficient hydraulic power.

Pro Series Electric Torque Wrench Pump

- Digital (LCD) display features a built-in hour meter, pressure display and shows self-diagnostic, cycle-count and low voltage warning information. These premium features are not available on any other pump – anywhere!
- Auto-Cycle feature provides continuous cycle operation of the torque wrench as long as the advance button is pressed (pump can be used with or without Auto-Cycle feature).

ZU4T-Series, Torque Pump Ordering Guide

Page: 65

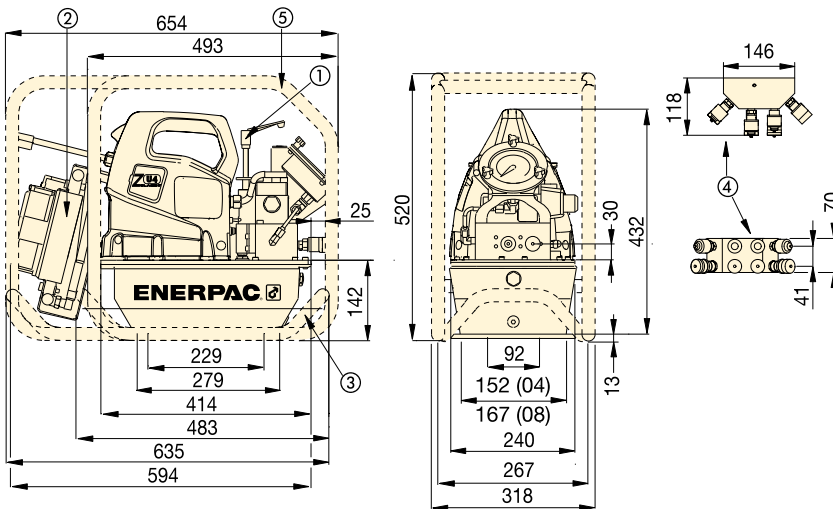

- ① User adjustable relief valve
- ② Heat Exchanger (optional)
- ③ Skidbar (optional)
- ④ 4-wrench manifold (optional)
- ⑤ Roll cage (optional)

ZU4T-Series Torque Pumps

ZU4T-Series Performance Chart									
Motor Size (kW)	Output Flow Rate (l/min)				Motor Electrical Specification (Volt - Phase - Hz)	Sound Level (dBA)	Relief Valve Adjustment Range (bar)		
	7 bar	50 bar	350 bar	700 bar					
1,25	11,5	8,8	1,2	1,0	115 - 1 - 50/60 208-240 - 1 - 50/60	85-90	124-700		

ZU4T Series



Reservoir Capacity:

4,6 - 6,8 litres

Flow at Rated Pressure:

1,0 l/min

Motor Size:

1,25 kW

Maximum Operating Pressure:

700 bar



Bolting Integrity Software

Enerpac Bolting Integrity Software Solutions play a key role in implementing and managing an Integrity Program for bolted connections. The software offers Tool selection, Bolt Load calculations and Tool pressure settings, as well as, a combined Application Data Sheet and Joint Completion Report. Custom Joint information can also be entered.

Page: 142



Overlay Kit with Gauge

Available separately for use with ZU4T-Series Classic: **GT4015Q** includes gauge and torque overlays for all Enerpac torque wrenches.

OIL FLOW VERSUS PRESSURE

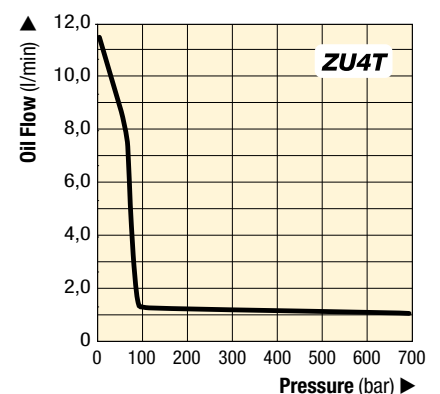



4-Wrench Manifold

- For simultaneous operation of multiple torque wrenches.

Accessory Kit * Model Nr.	Can be used on ZU4T-Series torque pumps
ZTM-Q *	for 700 bar torque wrenches

* 4-Wrench Manifold adds 2,7 kg to pump weight.



Skid Bar

- Provides greater pump stability on soft or uneven surfaces
- Provides easy two-handed lift.

Accessory Kit Model Nr.	Can be used on ZU4T-Series torque pumps
SBZ-4	4,6 and 6,8 litres reservoir ¹⁾
SBZ-4L	4,6 and 6,8 litres reservoir ²⁾

¹⁾ Without heat exchanger 2,2 kg.

²⁾ With heat exchanger 3,2 kg.



Heat Exchanger

- Removes heat from the bypass oil to provide cooler operation
- Stabilizes oil viscosity, increasing oil life and reduces wear of pump and other hydraulic components.

Accessory Kit * Model Nr.	Can be used on ZU4T-Series torque pumps
ZHE-U115	115 V pumps
ZHE-U230	230 V pumps

* Heat Exchanger adds 4,1 kg to pump weight.



Roll Cage

- Protects pump
- Provides greater pump stability.

Thermal Transfer *	Max. Pressure	Max. Oil Flow	Voltage
(Btu/h)	(bar)	(l/min)	(VDC)
900	20,7	26,5	12

* At 1,9 l/min at 21 °C ambient temperature. Do not exceed maximum oil flow and pressure ratings. Heat exchanger is not suitable for water-glycol or high water-based fluids.

▼ These rigid steel wrenches with low profile interchangeable hexagon cassettes guarantee durability and maximum versatility in bolting applications.



Accessory Kit Model Nr.	Can be used on ZU4T-Series torque pumps
ZRC-04	4,6 and 6,8 litres reservoir ¹⁾
ZRC-04H	4,6 and 6,8 litres reservoir ²⁾

¹⁾ Without heat exchanger 4,3 kg.

²⁾ With heat exchanger 4,3 kg.



Torque Wrench Hoses

Use Enerpac twin safety hoses to connect your torque wrench to the pump.

For 700 bar	Model-Nr.
2 m long, 2 hoses	THQ702T
6 m long, 2 hoses	THQ706T
12 m long, 2 hoses	THQ712T

ZU4T-Series, Torque Pump Ordering Guide

▼ Select a pump from the model matrix at the bottom of the page.

The functionality of the pump can be determined by the model number. Utilize the guide below to select the best pump for the application.

Z	U	4	2	08	T	E	-	Q	H	M
1 Product Type	2 Motor Type	3 Flow Group	4 Valve Type	5 Reservoir Size	6 Valve Operation	7 Voltage	8 Must be Q	8 Factory Installed Accessories		

1 Product Type

Z = Pump series

2 Motor Type

U = Universal electric motor

3 Flow Group

4 = 1,0 l/min @ 700 bar

4 Valve Type

2 = Torque wrench valve

5 Reservoir Size

04 = 4,6 litres

08 = 6,8 litres

6 Valve Operation

T = **Pro Series pump** with solenoid valve and pendant, LCD Electric and pressure transducer

B = **Classic pump** with solenoid valve and pendant.

7 Voltage

B = 115V, 1 ph, 50/60 Hz

E = 208-240V, 1 ph, 50/60 Hz (with European plug CE RF compliant)

I = 208-240V, 1 ph, 50/60 Hz (with NEMA 6-15 plug)

8 Factory installed accessories

H = Heat exchanger

K = Skid bar

M = 4-wrench manifold

R = Roll cage

ZU4T Series



Reservoir Capacity:

4,6 - 6,8 litres

Flow at Rated Pressure:

1,0 l/min

Motor Size:

1,25 kW

Maximum Operating Pressure:

700 bar





Torque Pump Selection Matrix



For optimum speed and performance see the torque pump and hose selection matrix.

Page: 55

▼ ZU4T-SERIES CLASSIC TORQUE PUMP MODELS

ZU4T Classic ¹⁾ Model Numbers 230 VAC, 1 ph ²⁾	Reservoir Capacity (litres)	Factory Installed Accessories					 (kg)
		Heat Exchanger	Roll Cage	Skid Bar	4-Wrench Manifold		
ZU4204BE-Q (B, I)	4,6						33
ZU4208BE-Q (B, I)	6,8						35
ZU4204BE-QH (B, I)	4,6	●					40
ZU4208BE-QH (B, I)	6,8	●					39
ZU4204BE-QR (B)	4,6		●				37
ZU4208BE-QR (B)	6,8		●				39
ZU4204BE-QHR (B)	4,6	●	●				41
ZU4208BE-QHR (B, I)	6,8	●	●				44
ZU4208BE-QHK (B, I)	6,8	●		●			42
ZU4208BE-QHM (B, I)	6,8	●			●		42
ZU4208BE-QMR (B)	6,8		●		●		42
ZU4208BE-QHMR (B, I)	6,8	●	●		●		46

▼ ZU4T-SERIES PRO TORQUE PUMP MODELS

ZU4T Pro Model Numbers 230 VAC, 1 ph ³⁾	Reservoir Capacity (litres)	Factory Installed Accessories					 (kg)
		Heat Exchanger	Roll Cage	Skid Bar	4-Wrench Manifold		
ZU4204TE-Q (B, I)	4,6						31
ZU4208TE-Q (B, I)	6,8						34
ZU4204TE-QH (B, I)	4,6	●					35
ZU4208TE-QH (B, I)	6,8	●					38
ZU4204TE-QR (B)	4,6		●				35
ZU4208TE-QR (B)	6,8		●				38
ZU4204TE-QHR (B)	4,6	●	●				40
ZU4208TE-QHR (B, I)	6,8	●	●				42
ZU4208TE-QHK (B, I)	6,8	●		●			41
ZU4208TE-QHM (B, I)	6,8	●			●		41
ZU4208TE-QMR (B)	6,8		●		●		41
ZU4208TE-QHMR (B, I)	6,8	●	●		●		45

¹⁾ Classic Electric Pump has traditional electro-mechanical components (transformers, relays, switches) in place of solid-state electronics.

²⁾ "B" indicates pump is 115V, 1-phase, 50/60 Hz. Model number example: **ZU4204BB-QHR**.

"I" indicates pump is 208-240V, 1-phase, 50/60 Hz with NEMA 6-15 plug. Model number example: **ZU4208BI-QHR**.

³⁾ "B" indicates pump is 115V, 1-phase, 50/60 Hz. Model number example: **ZU4204TB-QHR**.

"I" indicates pump is 208-240V, 1-phase, 50/60 Hz with NEMA 6-15 plug. Model number example: **ZU4204TI-QHR**.

▼ ZE4204TE-QHR



- **Auto-Cycle feature provides continuous cycle operation of the torque wrench as long as the advance button is pressed (pump can be used with or without auto cycle feature)**
- **LCD readout provides pressure and torque display and a number of diagnostic and readout capabilities never before offered on a portable electric pump**
- **Totally enclosed, fan-cooled industrial electric motors supply extended life and stand up to harsh industrial environments**
- **High-strength, molded electrical enclosure protects electronics, power supplies and LCD readout from harsh environments.**

Z Tough, Dependable Innovative CLASS



Pro-Series

Back-lit LCD and Pressure Transducer featuring Auto-Cycle Technology.

- Torque wrench model is selectable
- "Auto cycle" setting easily programmable.
- Digital read-out and "Autocycle" setting
- Pump usage information, hour and cycle counts
- Low-voltage warning and recording
- Self-test and diagnostic capabilities
- Information can be displayed in English, French, German, Italian, Spanish and Portuguese
- Pressure transducer is more accurate and durable than analog gauges
- Easy-viewing variable rate display
- Display pressure in bar, MPa or psi.



◀ The ZE4T-Series torque wrench pumps are perfectly matched for this W2000X wrench.



Bolting Integrity Software

Enerpac Bolting Integrity Software Solutions play a key role in

implementing and managing an Integrity Program for bolted connections.

The software offers Tool selection, Bolt Load calculations and Tool pressure settings, as well as, a combined Application Data Sheet and Joint Completion Report.

Custom Joint information can also be entered.

ZE4T AND ZE5T-SERIES OIL FLOW VERSUS PRESSURE

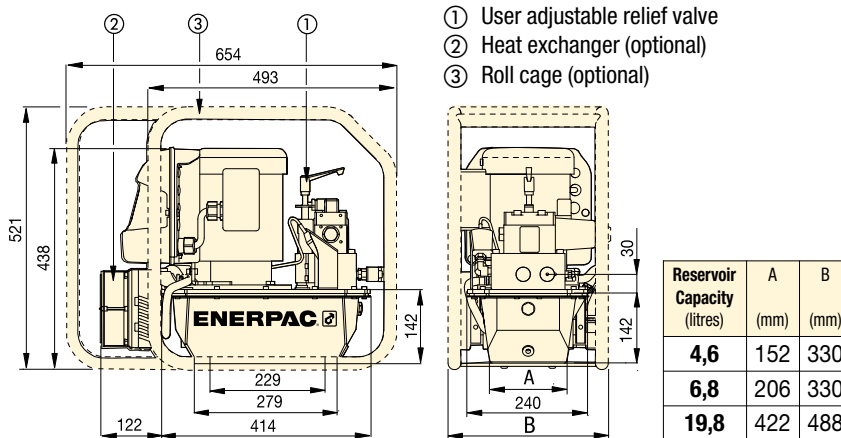
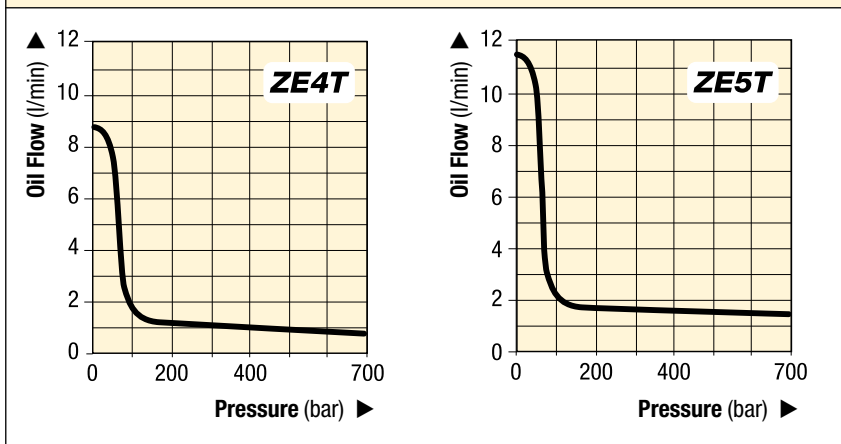

ZE4T and ZE5T-Series

▼ PERFORMANCE CHART

Pump Series	Output Flow Rate at 50 Hz (l/min)				Motor Size (kW)	Relief Valve Adjustment Range (bar)	Sound Level (dBA)
	7 bar	50 bar	350 bar	700 bar			
ZE4T	8,8	8,1	0,9	0,8	1,1	70 - 700	75
ZE5T	11,8	11,2	1,7	1,6	2,2	70 - 700	75

For Use With Wrenches	Model Number ¹⁾	Reservoir Capacity (litres)	Factory Installed Accessories			Weight (kg)
			Heat Exchanger	Roll Cage	4-Wrench Manifold	
All Series	ZE4204TE-QR (B)	4,6		●		54
	ZE4204TE-QHR (B)	4,6	●	●		59
	ZE4208TE-QHR (B)	6,8	●	●		61
	ZE4208TE-QHMR (B)	6,8	●	●	●	64
All Series	ZE5204TW-QHR (G, J)	4,6	●	●		64
	ZE5208TW-QHR (G, J)	6,8	●	●		67
	ZE5208TW-QHMR (G, J)	6,8	●	●	●	70
	ZE5220TW-QHR (G, J)	19,8	●	●		88

¹⁾ "B" suffix model numbers shown are 115 VAC, 1-phase, 50/60 Hz. Model number order example: **ZE4204TB-QR**.
 "E" indicates pump available in 208-240 VAC, 1 phase, 50/60 Hz with European plug and CE EMC compliant.
 "J" indicates pump available in 460-480 VAC, 3-phase, 50/60 Hz. Model number order example: **ZE5208TJ-QHR**.
 "G" indicates pump available in 208-240 VAC, 3-phase, 50/60 Hz. Model number order example: **ZE5208TG-QHR**.
 "W" indicates pump available in 380-415 VAC, 3-phase, 50/60 Hz. Model number order example: **ZE5208TW-QHR**.

ZE4T ZE5T Series



Reservoir Capacity:

4,6 - 19,8 litres

Flow at Rated Pressure:

0,82 - 1,64 l/min

Motor Size:

1,1 - 2,2 kW

Maximum Operating Pressure:

700 bar



Torque Wrench Pump Selection Matrix

For optimum speed and performance see the torque wrench pump and hose selection matrix.

Page: 55



Accessories

Descriptions can be found in the ZU4T-Series pump section.

Page: 64



Torque Wrench Hoses

Use Enerpac 700 bar THQ-Series torque wrench hoses with torque wrenches and pumps.

2 m long, 2 hoses	THQ702T
6 m long, 2 hoses	THQ706T
12 m long, 2 hoses	THQ712T

▼ LA2504TX-QR, Air-Driven Hydraulic Torque Pump

Ex IIC T4 Gc
IIIC T135°C Dc



Lightweight and Compact



Torque Pump Selection Matrix

For optimum speed and performance see the torque wrench and pump matrix.

Page: 55



Torque Wrench Hoses

Use Enerpac THQ-Series hoses with torque pumps to ensure the integrity of your hydraulic system.

For 700 bar	Model Nr.
2 m long, 2 hoses	THQ702T
6 m long, 2 hoses	THQ706T
12 m long, 2 hoses	THQ712T

Page: 100

Improved Operator Efficiency and Ergonomics

- Easy to lift, transport and maneuver
- Hand carry where no crane, hoist or elevator is available
- One person transport up ladders and stairs
- Ideal for use on narrow or constrained scaffolding, catwalks, pipe racks and lifts.

High Productivity

- Proven 3 piston design provides leading fastening and breakout speed to stay on time and under budget
- ATEX certified to meet worksite compliance requirements.

Reduce Equipment Downtime

- Roll cage with reinforcement to support and protect FRL
- Rugged 1/2" NPTF air supply connection with integrated roll cage support
- Key components are easy to access and service.

Standard Features

- 4,5 m pendant cord for mobility around work site
- 100 mm calibrated gauge with certificate, scale in bar and psi
- Roll cage and Filter-Regulator-Lubricator (FRL).



ATEX Certified

The LAT-Series air-driven pumps are tested and certified according to the ATEX Directive 2014/34/EU.

The explosion protection is for Equipment Group II, Equipment Category 2 (Hazardous Area Zone 1), in Gas and/or Dust atmospheres.

Each LAT-Series air-driven pump contains the following markings:

Ex IIC T4 Gc and Ex IIIC T135°C Dc

Ex IIC T4 Gc
IIIC T135°C Dc



Air-Driven Hydraulic Torque Pump



LAT-Series Air-Driven Torque Pump

The Enerpac LAT Air-Driven Torque Pump combines compact design and high productivity for bolting applications in areas hard to access with larger air powered pumps.

Whether on an offshore platform, refinery or mine anywhere in the world, the pump is built for the toughest worksite environments.

Featuring a proven Enerpac piston design, reinforced FRL support and air supply connection, the LAT-pump will provide years of reliable service with fastening and breakout speeds to keep you on schedule and under budget.

LAT Series



Reservoir Capacity:

3,0 litres

Flow at Rated Pressure:

0,4 l/min

Maximum Operating Pressure:

700 bar

- ▼ Rugged 1/2" NPTF air supply connection with integrated roll cage support.



- ▼ Roll cage design supports and protects Filter-Regulator-Lubricator (FRL).



- ▼ Proven 3 piston design provides leading speed.



- ▼ Skid Rail accessory DD8365920K bolts to bottom of reservoir to prevent wear from rough surfaces.

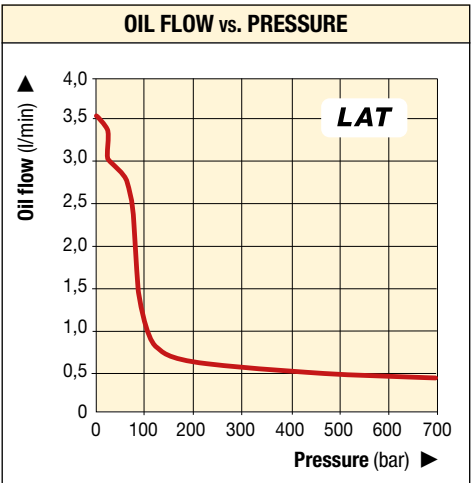

- ▼ LAT-Series, the portable and compact torque pump.



Usable Oil Capacity (litres)	Model Number *	Output Flow Rate (l/min)			Valve Type	Air Pressure Range (bar)	Air Consumption (l/min)	Sound Level (dBA)	Dimensions (mm)			Weight (kg)
		No Load	350 bar	700 bar					Length	Width	Height	
1,9	LA2504TX-QR	3,5	0,6	0,4	4-way, 2-pos.	4,5 - 6,9	1389	87 - 90	435	250	375	18,0

* Enerpac Spin-On couplers are included. Pump hydraulic port thread size is 1/4"-18 NPTF.

▼ ZA4204TX-QR



Ex II 2 GD ck T4
DEKRA 0602

ZA4208TX-QRU105 Complete Set with Pump, Hose THQ706T and Roll Cage:

- Fine air pressure adjustment for very accurate torque control
- High bypass pressure (180 bar) for faster torque cycles
- Improved wrench performance at low pressure

Standard ZA4T-pump models:

- Two-speed operation and 100 bar by-pass pressure reduces cycle time for improved productivity
- Glycerin filled pressure gauge with transparent overlays in Nm and Ft.lbs for Enerpac torque wrenches provide a quick torque reference
- Standard Regulator-Filter-Lubricator with removable bowls and auto drain
- Heat exchanger warms exhaust air to prevent freezing and cools the oil
- Ergonomic pendant allows remote operation up to 6 m.



◀ Most hydraulic torque wrenches can be powered by the Enerpac ZA4T-Series torque pumps.

Z Tough, Dependable Innovative CLASS



Gauge with Overlay Kit

Gauge Overlay Kits are available separately for use with ZA4T-Series pumps:

GT4015Q includes gauge and overlays for all Enerpac all S, W, RSL, DSX and HMT-Series torque wrenches.



Torque Pump Selection Matrix

For optimum speed and performance see the torque pump selection matrix.

Page: 55



Torque Wrench Hoses

Use Enerpac THQ-Series hoses with torque pumps to ensure the integrity of your hydraulic system.

For 700 bar	Model Nr.
2 m long, 2 hoses	THQ702T
6 m long, 2 hoses	THQ706T
12 m long, 2 hoses	THQ712T

Page: 100



PowaPak™ Air Torque Pump

ZA4208TX-QR0P Pump with Stainless Steel Roll Cage and Certified Lifting Eye.

Page: 74

Air Driven Torque Pumps



ZA4T-Pump Applications

The ZA4T-Series pump is best suited to power medium to large size torque wrenches.

Patent-pending Z-Class technology provides high by-pass pressures for increased productivity.

Its high power to weight ratio and compact design make it ideal for applications which require easy transport of the pump.

All ZA4T-Series pump models meet CE, CSA and TÜV safety requirements. For further application assistance contact your local Enerpac office.

ATEX 95 Certified

The ZA4T-Series pumps are tested and certified according to the Equipment Directive 94 / 9 / EC "ATEX Directive".

The explosion protection is for Equipment Group II, Equipment Category 2 (Hazardous Area Zone 1), in Gas and/or Dust atmospheres. The ZA4T-Series pumps are marked with: **Ex II 2 GD ck T4**.



ZA4T Series



Reservoir Capacity:

4,6 - 6,8 litres

Flow at Rated Pressure:

1,0 l/min

Air Consumption:

600 - 2840 l/min

Maximum Operating Pressure:

700 bar

OIL FLOW VERSUS PRESSURE

6,9 bar dynamic air pressure at 2840 l/min

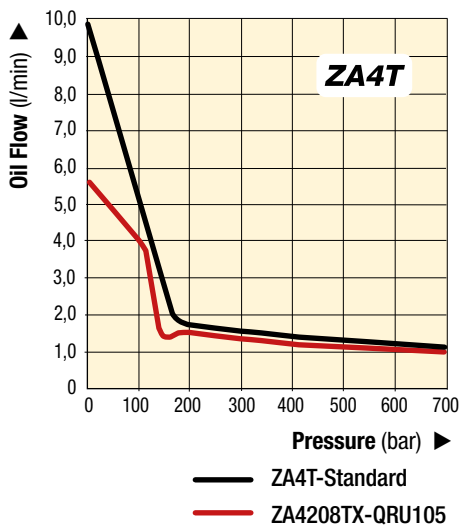

Accessory Options

Available by placing the following additional suffix at the end of the model number:

- K** = Skid bar
- M** = 4-wrench manifold
- R** = Roll cage.

Page: 72

▼ ZA4208TX-QRU105 for improved wrench performance and torque control at low pressure.



COMMON PUMP MODELS

For Use With Torque Wrenches	Maximum Operating Pressure (bar)	Model Number	Reservoir Capacity (litres)	Weight (kg)
all S, W, RSL, DSX and HMT-Series	700	ZA4208TX-QRU105 *	6,8	45
	700	ZA4204TX-Q	4,6	42
	700	ZA4208TX-Q	6,8	47
	700	ZA4204TX-QR **	4,6	46
	700	ZA4208TX-QR **	6,8	51

* Standard with roll cage, with THQ706T hose and fine air pressure adjustment for very accurate torque control. Pump weight 45 kg, complete set including hose weight 58 kg.

** With Roll Cage.



Skid Bar

- Provides greater pump stability on soft or uneven surfaces
- Provides easy two-handed lift.



4-Wrench Manifold

- For simultaneous operation of multiple torque wrenches
- Can be factory installed or ordered separately.



Roll Cage

- Protects pump
- Provides greater pump stability.

Accessory Kit * Model Nr.	Can be used on ZA4T-Series torque wrench pumps
SBZ-4	Reservoir 04 and 08

* Add suffix **K** for factory installation.
Weight skid bar 2,2 kg.
Ordering Example: ZA4208TX-QK

Accessory Kit * Model Nr.	Can be used on ZA4T-Series torque wrench pumps
ZTM-Q	for 700 bar torque wrenches

* Add suffix **M** for factory installation. This option cannot be installed onto the ZA4208TX-QRU105 pump, as the valve manifold is different.
Weight manifold 4,5 kg.
Ordering Example: ZA4208TX-QM

Accessory Kit * Model Nr.	Can be used on ZA4T-Series torque wrench pumps
ZRC-04	Reservoir 04 and 08

* Add suffix **R** for factory installation.
Roll cage weight 3,4 kg.
Ordering Example: ZA4208TX-QR



Torque Wrench Hoses

Use Enerpac THQ-700 Series hoses with torque wrenches to ensure the integrity of your hydraulic system.

For 700 bar	Model Nr.
2 m long, 2 hoses	THQ702T
6 m long, 2 hoses	THQ706T
12 m long, 2 hoses	THQ712T

Page: 100



PowePak™ Air Torque Pump

ZA4T-Pump with Stainless Steel Roll Cage and Certified Lifting Eye.

Page: 74

Ordering Matrix and Specifications

▼ This is how a ZA4T-Series torque pump model number is built up:

Z	A	4	2	08	T	X	-	Q	M	R
1 Product Type	2 Motor Type	3 Flow Group	4 Valve Type	5 Reservoir Size	6 Valve Operation	7 Voltage		8 Must be Q	8 Options	8 Options

1 Product Type

Z = Pump series

2 Motor Type

A = Air motor

3 Flow Group

4 = 1,0 l/min @ 700 bar

4 Valve Type

2 = Torque Wrench Valve

5 Reservoir Size

04 = 4,6 litres

08 = 6,8 litres

6 Valve Operation

T = Air operated valve with pendant

7 Voltage

X = Not applicable

8 Options

Q = 700 bar couplers for use with S, W, RSL, DSX and HMT-Series or other wrenches

K = Skid bar

M = 4-wrench manifold

R = Roll cage

ZA4T Series



Reservoir Capacity:

4,6 - 6,8 litres

Flow at Rated Pressure:

1,0 l/min

Air Consumption:

600 - 2840 l/min

Maximum Operating Pressure:

700 bar



How to order your ZA4T-Series torque pump

Model No. ZA4208TX-QMR

700 bar torque pump for use with all Enerpac wrenches and other 700 bar torque wrenches, 6,8 litres reservoir, 4-wrench manifold and roll cage.

Refer to the selection matrix for optimum wrench and torque pump combinations.

Page: 55



Bolting Integrity Software

Enerpac Bolting Integrity Software Solutions play a key role in

implementing and managing an Integrity Program for bolted connections.

The software offers Tool selection, Bolt Load calculations and Tool pressure settings, as well as, a combined Application Data Sheet and Joint Completion Report.

Custom Joint information can also be entered.

Page: 142

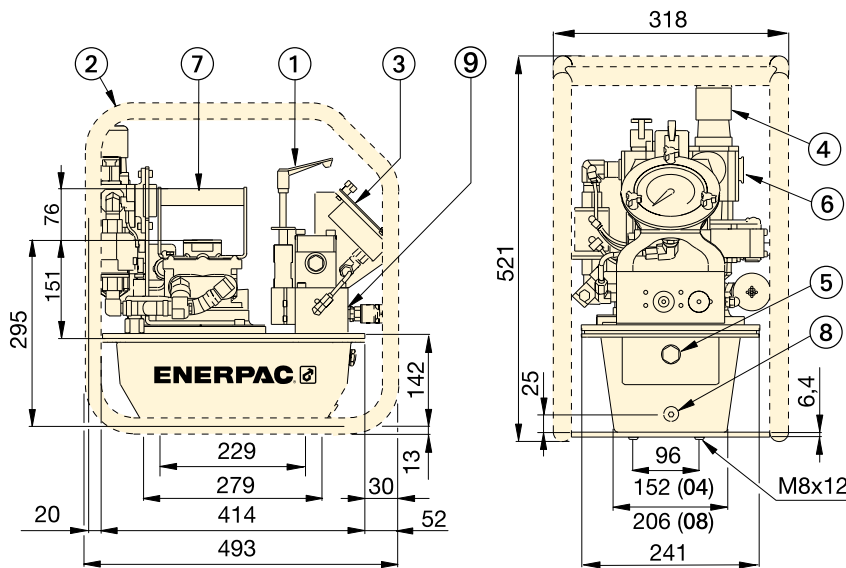

- ① User adjustable relief valve
- ② Roll Cage (optional)
- ③ Gauge with overlays
- ④ Filter/lubricator/regulator
- ⑤ Oil level sight gauge

- ⑥ Air input 1/2" NPTF
- ⑦ Standard handle
- ⑧ Oil drain
- ⑨ 1/4"-18 NPTF Oil outlet

ZA4T-Series Performance

Pump Model	Output Flow Rate (l/min)				By-pass pressure (bar)	Dynamic Air Pressure Range (bar)	Air Consumption (l/min)	Sound Level (dBA)	Relief Valve Adjustment Range (bar)
	7 bar	50 bar	350 bar	700 bar					
ZA4208TX-QRU105	5,7	4,5	1,4	1,0	180	7,0	600 - 2840	85-90	124 - 700
ZA4T Standard	9,8	8,2	1,4	1,0	100	4,0 - 6,9	600 - 2840	85-90	124 - 700

▼ ZA4208TX-QR0P



New ZA4T with Stainless Steel Roll Cage and Certified Lifting Eye

- **Stainless-Steel Roll Cage** resists corrosion
- **Certified Lifting Eye** for transporting pump between levels
- **Two-speed operation** and high by-pass pressure reduces cycle time for improved productivity
- **Integrated heat exchanger** warms exhaust air to prevent freezing and cools the oil
- **Fine hydraulic pressure adjustment** for accurate torque control
- **Improved wrench speed** at low hydraulic pressure due to the expanded 1st stage bypass setting
- **Pendant** allows operation up to 6 metres (20 ft)
- **Filter-Regulator-Lubricator** with removable bowls and auto drain is standard
- **Calibrated, glycerine filled gauge** with display in bar and psi
- **ATEX-tested and certified.**



Torque Pump Selection Matrix

For optimum speed and performance see the torque wrench pump selection matrix.

Page: 55



Torque Wrench Hoses

Use Enerpac THQ-Series hoses with torque wrenches to ensure the integrity of your hydraulic system.

For 700 bar	Model-Nr.
2 m long, 2 hoses	THQ702T
6 m long, 2 hoses	THQ706T
12 m long, 2 hoses	THQ712T

▼ Certified lifting eye.



PowaPak™ Air Torque Pump



PowaPak™ Air Torque Pump

The ZA4208TX-QROP was developed for the high demands of the oil and gas, chemical processing, rental and other industrial markets.

The stainless-steel roll cage resists corrosion and surface damage reducing the maintenance required to prepare the pump for the next job.

The certified lifting eye enables the pump to be transported between levels with a lifting hook avoiding time consuming strapping.

ATEX-Certified

The ZA4T air-driven torque pump is tested and certified according to the ATEX Directive 2014/34/EU.

The explosion protection is for Equipment Group II, Equipment Category 2 (Hazardous Area Zone 1), in Gas and /or Dust atmospheres.

Each pump contains the following markings:

Ex IIC T4 Gc

Ex IIIC T135°C Dc



ZA4T Series



Reservoir Capacity:

6,8 litres

Flow at Rated Pressure:

1,0 l/min

Air Consumption:

600 - 2840 l/min

Maximum Operating Pressure:

700 bar

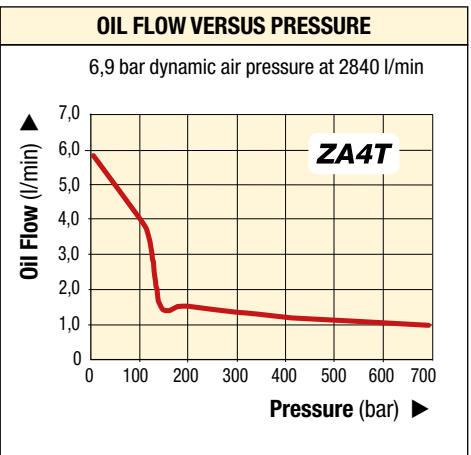
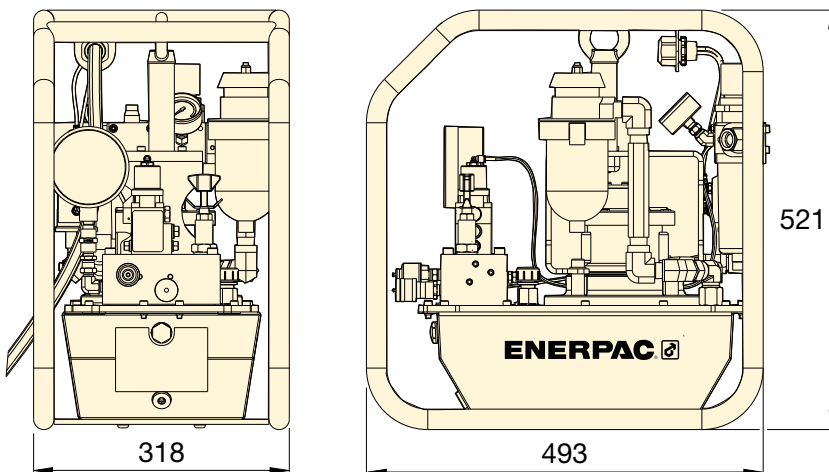

Bolting Integrity Software

Enerpac Bolting Integrity Software Solutions play a key role in implementing and managing an Integrity Program for bolted connections.

The software offers Tool selection, Bolt Load calculations and Tool pressure settings, as well as, a combined Application Data Sheet and Joint Completion Report.

Custom Joint information can also be entered.

Maximum Operating Pressure (bar)	Model Number	Reservoir Capacity (litres)	Output Flow Rate (l/min)			Dynamic Air Pressure Range (bar)	Air Consumption (l/min)	Weight (kg)
			7 bar	350 bar	700 bar			
700	ZA4208TX-QROP	6,8	5,7	1,3	1,0	4,1-6,9	600-2840	52

▼ HM10 Hydramax® Topside Tensioner



- Fifteen load cells from ¾" to 4" / M20 to M100
- Twin ports for quick connection of multiple tools
- High bolt load capacity at max. 1500 bar (21.750 psi)
- Long stroke capability of 15 mm (9/16 inch) with over stroke elimination
- HM01 to HM05: mechanical over-stroke prevention, no spring assist; HM06 to HM15: relief valve for over-stroke prevention, spring assist
- Quick release bridge
- Stroke indicator
- Captive socket – eliminates falling object risk
- Interchangeable adapter kits available
- Anti-slip grip for more secure handling
- HM-Series HydraMax® Tensioners comply to following: Machine Directive 2006/42/EC, ASME B30.1, EN-ISO 4413:2010 and EN-ISO 12100:2010.



◀ Enerpac HM-Series HydraMax® tensioners have been designed to generate high bolt loads associated with compact flanges, while providing versatility for maximum bolt coverage,

High Bolt Load Capacities, Superior Performance



HydraMax® Topside Tensioners

The HM-Series tensioners have been designed to fit all standard flanges, including ANSI, API and Compact flanges based on Norsok L005 and generates 30% more load capacity than traditional tensioners.



Tensioning Pumps, Hoses and Couplers

High pressure pumps, hoses and fittings matched for use with the Enerpac Bolt Tensioners. See enerpac.com

Page: 90



Ultra-high Pressure

This tool operates at ultra-high pressure, use only the specified fittings and hoses designed for these pressures.

Page: 91



How to Order HydraMax® Tensioners

To provide maximum flexibility Load Cells are ordered separately from Adaptor and Bridge Kits.

Example, to order a complete tensioner for a M24 x 3 threaded bolt order:

1 x Load Cell with tommy bar: **HM03-LC**

1 x Adaptor and Bridge Kit: **HM03BPM-NRS02430**



Bolting Integrity Software

The software offers Tool selection, Bolt Load calculations and Tool pressure settings, as well as, a combined Application data sheet and Joint completion report. Custom Joint information can also be entered.

Page: 140

HydraMax® Torsioners



Thread and Pitch Sizes

Contact Enerpac for different thread or pitch sizes.

Alternative size adaptor kits can be supplied upon request.

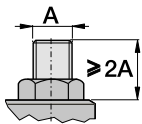

Minimum Stud Protrusion

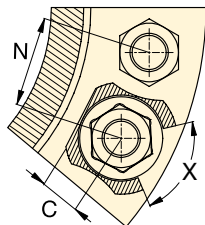

X = Minimum socket rotation 60°

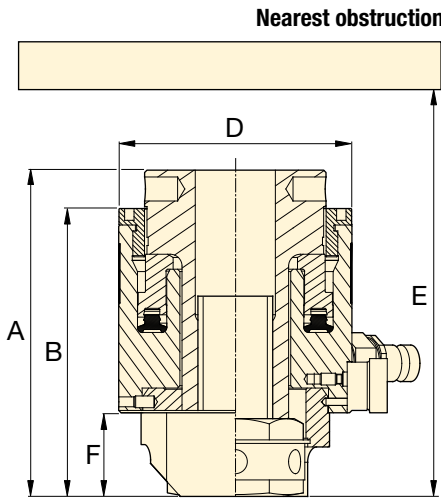

HM Series



Bolt Range:

M20 - M39, 3/4" - 1 1/2"

Maximum Load Capacity:

134 - 624 kN

Stroke:

10 - 15 mm *

Maximum Operating Pressure:

1500 bar

* Stroke HM01 models 10 mm

Strokes all other HM-models 15 mm.

Load Cell Model Number *	Thread Size	Adaptor and Bridge Kit Model Number	Cylinder Effective Area (mm ²)	Maximum Load Capacity (kN)	Dimensions (mm)							Load Cell Weight (kg)	Adaptor and Bridge Kit Weight (kg)
					A	B	C	D	E min.	F	N min.		
HM01-LC	M20 x 2,5	HM01BPM-NRS02025	894	134,0	112	96	15	61	208	28	51	1,6	0,6
	3/4" - 10UN	HM01BP-NRS0750U10	894	134,0	112	96	15	61	208	28	51	1,6	0,6
HM02-LC	M20 x 2,5	HM02BPM-NRS02025	1240	186,0	119	103	15	69	227	28	53	1,8	0,9
	M22 x 2,5	HM02BPM-NRS02225	1240	186,0	119	103	18	69	225	28	54	1,8	0,9
	3/4" - 10UN	HM02BP-NRS0750U10	1240	186,0	119	103	15	69	227	28	52	1,8	0,9
	7/8" - 9UN	HM02BP-NRS0875U09	1240	186,0	119	103	18	69	225	28	56	1,8	0,8
HM03-LC	M20 x 2,5	HM03BPM-NRS02025	1628	244,1	120	105	15	77	230	28	57	2,2	1,1
	M22 x 2,5	HM03BPM-NRS02225	1628	244,1	120	105	18	77	228	28	58	2,2	1,1
	M24 x 3	HM03BPM-NRS02430	1628	244,1	120	110	20	77	232	33	59	2,2	1,1
	3/4" - 10UN	HM03BP-NRS0750U10	1628	244,1	120	105	15	77	230	28	56	2,2	1,1
	7/8" - 9UN	HM03BP-NRS0875U09	1628	244,1	120	105	18	77	228	28	58	2,2	1,1
	1" - 8UN	HM03BP-NRS1000U08	1628	244,1	125	110	20	77	232	33	60	2,2	1,1
HM04-LC	M22 x 2,5	HM04BPM-NRS02225	2159	323,8	128	112	18	90	250	28	62	2,7	1,6
	M24 x 3	HM04BPM-NRS02430	2159	323,8	129	117	20	90	255	33	63	2,7	1,6
	M27 x 3	HM04BPM-NRS02730	2159	323,8	134	117	20	90	256	34	65	2,7	1,7
	M30 x 3,5	HM04BPM-NRS03035	2159	323,8	137	120	23	90	257	36	66	2,7	1,7
	7/8" - 9UN	HM04BP-NRS0875U09	2159	323,8	129	112	18	90	250	28	62	2,7	1,6
	1" - 8UN	HM04BP-NRS1000U08	2159	323,8	134	117	20	90	255	33	64	2,7	1,7
	1 1/8" - 8UN	HM04BP-NRS1125U08	2159	323,8	137	120	23	90	257	36	65	2,7	1,7
HM05-LC	M24 x 3	HM05BPM-NRS02430	2752	412,7	131	119	20	99	263	33	68	3,3	1,9
	M27 x 3	HM05BPM-NRS02730	2752	412,7	136	119	20	99	263	34	69	3,3	2,0
	M30 x 3,5	HM05BPM-NRS03035	2752	412,7	139	122	23	99	261	36	71	3,3	2,0
	M33 x 3,5	HM05BPM-NRS03335	2752	412,7	142	125	27	99	262	39	72	3,3	2,1
	1" - 8UN	HM05BP-NRS1000U08	2752	412,7	136	119	20	99	263	33	68	3,3	2,1
	1 1/8" - 8UN	HM05BP-NRS1125U08	2752	412,7	139	122	23	99	261	36	70	3,3	2,1
	1 1/4" - 8UN	HM05BP-NRS1250U08	2752	412,7	142	125	27	99	262	39	71	3,3	2,1
HM06-LC	M30 x 3,5	HM06BPM-NRS03035	4162	624,1	143	125	23	118	266	36	80	4,5	2,8
	M33 x 3,5	HM06BPM-NRS03335	4162	624,1	146	128	27	118	269	39	82	4,5	2,9
	M36 x 4	HM06BPM-NRS03640	4162	624,1	149	131	32	118	273	42	83	4,5	3,0
	M39 x 4	HM06BPM-NRS03940	4162	624,1	152	134	33	118	277	45	85	4,5	3,1
	1 1/8" - 8UN	HM06BP-NRS1125U08	4162	624,1	143	125	23	118	266	36	79	4,5	2,8
	1 1/4" - 8UN	HM06BP-NRS1250U08	4162	624,1	146	128	27	118	269	39	81	4,5	2,9
	1 3/8" - 8UN	HM06BP-NRS1375U08	4162	624,1	149	131	32	118	273	32	82	4,5	3,0
	1 1/2" - 8UN	HM06BP-NRS1500U08	4162	624,1	152	134	33	118	277	45	84	4,5	3,1

* Tommy Bar is included with Load Cell.



Thread and Pitch Sizes

Contact Enerpac for different thread or pitch sizes. Alternative size adaptor kits can be supplied upon request.

HM Series



Bolt Range:

M33 - M52, 1¼ - 2"

Maximum Load Capacity:

746 - 1179 kN

Stroke:

15 mm

Maximum Operating Pressure:

1500 bar

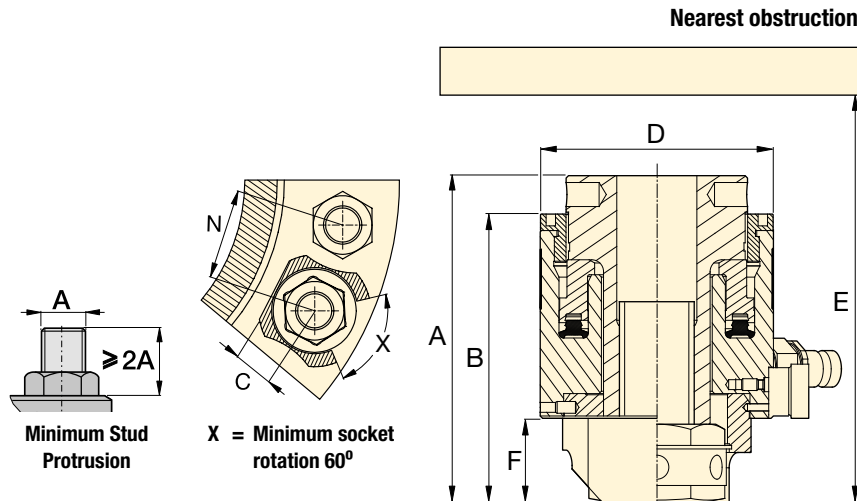

Load Cell Model Number *	Thread Size	Adaptor and Bridge Kit Model Number	Cylinder Effective Area (mm²)	Maximum Load Capacity (kN)	Dimensions (mm)							Load Cell Weight (kg)	Adaptor and Bridge Kit Weight (kg)
					A	B	C	D	E min.	F	N min.		
HM07-LC	M33 x 3,5	HM07BPM-NRS03335	4980	746,8	145	128	27	127	278	39	86	5,2	3,4
	M36 x 4	HM07BPM-NRS03640	4980	746,8	148	131	32	127	279	42	88	5,2	3,5
	M39 x 4	HM07BPM-NRS03940	4980	746,8	151	134	33	127	280	45	89	5,2	3,6
	M42 x 4,5	HM07BPM-NRS04245	4980	746,8	154	137	34	127	280	48	91	5,2	3,7
	1¼" - 8UN	HM07BP-NRS1250U08	4980	746,8	145	128	27	127	278	39	85	5,2	3,4
	1⅝" - 8UN	HM07BP-NRS1375U08	4980	746,8	148	131	32	127	279	42	87	5,2	3,5
	1½" - 8UN	HM07BP-NRS1500U08	4980	746,8	151	134	33	127	280	45	89	5,2	3,6
1⅝" - 8UN	HM07BP-NRS1625U08	4980	746,8	154	137	34	127	280	48	90	5,2	3,7	
HM08-LC	M36 x 4	HM08BPM-NRS03640	5869	880,1	149	133	32	137	283	42	93	6,3	3,9
	M39 x 4	HM08BPM-NRS03940	5869	880,1	152	136	33	137	284	45	94	6,3	4,0
	M42 x 4,5	HM08BPM-NRS04245	5869	880,1	155	139	34	137	284	48	96	6,3	4,1
	M45 x 4,5	HM08BPM-NRS04545	5869	880,1	158	142	39	137	285	51	97	6,3	4,4
	1⅝" - 8UN	HM08BP-NRS1375U08	5869	880,1	149	133	32	137	283	42	92	6,3	3,9
	1½" - 8UN	HM08BP-NRS1500U08	5869	880,1	152	136	33	137	284	45	94	6,3	4,0
	1⅝" - 8UN	HM08BP-NRS1625U08	5869	880,1	155	139	34	137	284	48	95	6,3	4,1
1¾" - 8UN	HM08BP-NRS1750U08	5869	880,1	158	142	39	137	285	51	97	6,3	4,4	
HM09-LC	M39 x 4	HM09BPM-NRS03940	6834	1024,9	152	136	33	145	278	45	98	6,5	5,0
	M42 x 4,5	HM09BPM-NRS04245	6834	1024,9	155	139	34	145	281	48	100	6,5	6,1
	M45 x 4,5	HM09BPM-NRS04545	6834	1024,9	158	142	39	145	285	51	101	6,5	5,1
	M48 x 5	HM09BPM-NRS04850	6834	1024,9	161	145	43	145	288	54	103	6,5	5,5
	1½" - 8UN	HM09BP-NRS1500U08	6834	1024,9	152	136	33	145	278	45	98	6,5	5,1
	1⅝" - 8UN	HM09BP-NRS1625U08	6834	1024,9	155	139	34	145	281	48	99	6,5	5,1
	1¾" - 8UN	HM09BP-NRS1750U08	6834	1024,9	158	142	39	145	285	51	101	6,5	5,0
1⅞" - 8UN	HM09BP-NRS1875U08	6834	1024,9	161	145	43	145	288	54	102	6,5	5,4	
HM10-LC	M42 x 4,5	HM10BPM-NRS04245	7868	1179,8	159	143	34	156	289	48	105	8,3	5,7
	M45 x 4,5	HM10BPM-NRS04545	7868	1179,8	162	146	39	156	293	51	107	8,3	5,7
	M48 x 5	HM10BPM-NRS04850	7868	1179,8	165	149	43	156	296	54	108	8,3	6,1
	M52 x 5	HM10BPM-NRS05250	7868	1179,8	169	153	44	156	301	58	110	8,3	6,3
	1⅝" - 8UN	HM10BP-NRS1625U08	7868	1179,8	159	143	34	156	289	48	105	8,3	5,7
	1¾" - 8UN	HM10BP-NRS1750U08	7868	1179,8	162	146	39	156	293	51	106	8,3	5,6
	1⅞" - 8UN	HM10BP-NRS1875U08	7868	1179,8	165	149	43	156	296	54	108	8,3	6,0
2" - 8UN	HM10BP-NRS2000U08	7868	1179,8	169	153	44	156	301	58	109	8,3	6,3	

* Load Cell with Tommy Bar.

HydraMax® Topside Tensioners

HM Series



Bolt Range:

M45 - M100, 1 3/4" - 4"

Maximum Load Capacity at 1500 bar:

1522 - 4650 kN

Stroke:

15 mm

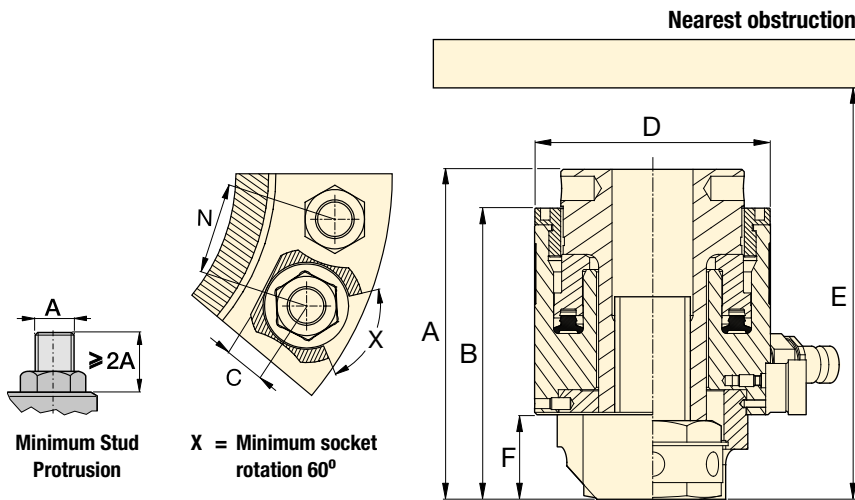

Load Cell Model Number *	Thread Size **	Adaptor and Bridge Kit Model Number	Cylinder Effective Area (mm ²)	Maximum Load Capacity (kN)	Dimensions (mm)							Load Cell Weight (kg)	Adaptor and Bridge Kit Weight (kg)
					A	B	C	D	E min.	F	N min.		
HM11-LC	M45 x 4,5	HM11BPM-NRS04545	10152	1522,5	167	146	39	175	297	51	116	10,5	7,4
	M48 x 5	HM11BPM-NRS04850	10152	1522,5	170	149	43	175	301	54	118	10,5	7,9
	M52 x 5	HM11BPM-NRS05250	10152	1522,5	174	153	44	175	306	58	120	10,5	8,1
	M56 x 5,5	HM11BPM-NRS05655	10152	1522,5	182	161	50	175	318	66	122	10,5	9,1
	M60 x 5,5	HM11BPM-NRS06055	10152	1522,5	182	161	50	175	323	66	124	10,5	8,7
	1 3/8" - 8UN	HM11BP-NRS1750U08	10152	1522,5	167	146	39	175	297	51	116	10,5	7,5
	1 7/8" - 8UN	HM11BP-NRS1875U08	10152	1522,5	170	149	43	175	301	54	117	10,5	7,9
	2" - 8UN	HM11BP-NRS2000U08	10152	1522,5	174	153	44	175	306	58	119	10,5	8,1
2 1/4" - 8UN	HM11BP-NRS2250U08	10152	1522,5	182	161	50	175	318	66	122	10,5	8,8	
HM12-LC	M48 x 5	HM12BPM-NRS04850	12722	1907,7	170	149	43	194	301	54	127	13,3	9,7
	M52 x 5	HM12BPM-NRS05250	12722	1907,7	174	153	44	194	306	58	129	13,3	9,8
	M56 x 5,5	HM12BPM-NRS05655	12722	1907,7	182	161	50	194	318	66	131	13,3	10,7
	M60 x 5,5	HM12BPM-NRS06055	12722	1907,7	182	161	50	194	323	66	133	13,3	10,4
	M64 x 6	HM12BPM-NRS06460	12722	1907,7	186	165	56	194	320	70	135	13,3	11,1
	1 7/8" - 8UN	HM12BP-NRS1875U08	12722	1907,7	170	149	43	194	301	54	127	13,3	9,6
	2" - 8UN	HM12BP-NRS2000U08	12722	1907,7	174	153	44	194	306	58	128	13,3	9,8
	2 1/4" - 8UN	HM12BP-NRS2250U08	12722	1907,7	182	161	50	194	318	66	132	13,3	10,4
2 1/2" - 8UN	HM12BP-NRS2500U08	12722	1907,7	186	165	56	194	320	70	135	13,3	10,8	
HM13-LC	M64 x 6	HM13BPM-NRS06460	16964	2544,0	195	172	56	219	337	70	148	17,6	14,5
	M68 x 6	HM13BPM-NRS06860	16964	2544,0	195	180	63	219	350	78	150	17,6	16,5
	M72 x 6	HM13BPM-NRS07260	16964	2544,0	203	185	69	219	347	82	152	17,6	16,0
	M76 x 6	HM13BPM-NRS07660	16964	2544,0	207	185	69	219	352	82	154	17,6	16,3
	2 1/2" - 8UN	HM13BP-NRS2500U08	16964	2544,0	195	172	56	219	337	70	147	17,6	14,2
	2 3/4" - 8UN	HM13BP-NRS2750U08	16964	2544,0	203	180	63	219	350	78	150	17,6	15,8
3" - 8UN	HM13BP-NRS3000U08	16964	2544,0	207	185	69	219	352	82	161	17,6	15,8	
HM14-LC	M72 x 6	HM14BPM-NRS07260	23451	3516,7	203	185	69	259	351	82	172	25,8	20,8
	M76 x 6	HM14BPM-NRS07660	23451	3516,7	207	185	69	259	352	82	174	25,8	21,3
	M80 x 6	HM14BPM-NRS08060	23451	3516,7	207	193	70	259	367	91	176	25,8	21,2
	M85 x 6	HM14BPM-NRS08560	23451	3516,7	216	193	70	259	374	91	178	25,8	22,9
	M90 x 6	HM14BPM-NRS09060	23451	3516,7	221	198	79	259	389	96	181	25,8	23,3
	3" - 8UN	HM14BP-NRS3000U08	23451	3516,7	207	185	69	259	352	82	174	25,8	20,4
	3 1/4" - 8UN	HM14BP-NRS3250U08	23451	3516,7	216	193	70	259	374	91	177	25,8	22,7
3 1/2" - 8UN	HM14BP-NRS3500U08	23451	3516,7	221	198	79	259	389	96	184	25,8	23,9	
HM15-LC	M90 x 6	HM15BPM-NRS09060	31008	4650,0	221	199	79	296	389	96	199	32,5	30,0
	M95 x 6	HM15BPM-NRS09560	31008	4650,0	226	205	81	296	405	101	202	32,5	33,7
	M100 x 6	HM15BPM-NRS10060	31008	4650,0	232	211	90	296	421	107	204	32,5	35,1
	3 1/2" - 8UN	HM15BP-NRS3500U08	31008	4650,0	221	199	79	296	389	96	198	32,5	29,5
	3 3/4" - 8UN	HM15BP-NRS3750U08	31008	4650,0	226	205	81	296	405	101	202	32,5	32,8
	4" - 8UN	HM15BP-NRS4000U08	31008	4650,0	232	211	90	296	421	107	210	32,5	34,0

* Load Cell with Tommy Bar.

** Contact Enerpac for different thread or pitch sizes. Alternative size adaptor kits can be supplied upon request.

▼ Shown: GT-Series Topside Bolt Tensioners



- Seven load cells from M16 to M105 or from 5/8" to 4"
- Twin ports for quick connection of multiple tools
- Only one size of bridge per size of load cell
- Detachable and rotational bridge simplifies tool positioning
- Full bridge window – increased access to socket
- Captive socket – eliminates falling object risk
- Piston stroke indicator
- Black surface treatment protects against corrosion
- Anti-slip grip for more secure handling
- Universal and multi-use tool
- GT-Series Tensioners comply to Machine Directive 2006/42/CE, ASME B30.1, EN-ISO 4413:2010 and EN-ISO 12100:2010.

Accurate & Reliable Extreme Performance Bolt Tensioners



Tensioning Pumps, Hoses and Couplers

High pressure pumps, hoses and fittings matched for use with the Enerpac Bolt Tensioners. See enerpac.com

Page: 90



Bolting Integrity Software

The software offers Tool selection, Bolt Load calculations and Tool pressure settings, as well as, a combined Application data sheet and Joint completion report. Custom Joint information can also be entered.

Page: 140



How to Order

To provide maximum flexibility Load Cell and Bridges are ordered separately from Adaptor Kits.

Example, to order a complete tensioner for a M36 x 4 threaded bolt order:

1 x Load Cell and Bridge: **GT2-LCB**
1 x Adaptor Kit: **GT2PM-NRS03640**

Load Cell * and Bridge Model Number	Thread Size	Adaptor Kit Model Number	Cylinder Effective Area (mm ²)	Maximum Load Capacity (kN)	Dimensions (mm)							Load Cell and Bridge Weight (kg)	Adaptor Kit Weight (kg)
					A	B	C	D	E min.	F	N min.		
GT1-LCB	M16 x 2	GT1PM-NRS01620	1495,4	224,3	135	113	27	86	243	44	57	3,0	1,6
	M18 x 2,5	GT1PM-NRS01825	1495,4	224,3	135	113	27	86	243	44	58	3,0	1,5
	M20 x 2,5	GT1PM-NRS02025	1495,4	224,3	135	113	27	86	243	44	59	3,0	1,4
	M24 x 3	GT1PM-NRS02430	1495,4	224,3	135	113	27	86	243	44	61	3,0	1,3
	M27 x 3	GT1PM-NRS02730	1495,4	224,3	135	113	27	86	243	44	64	3,0	1,2
	M30 x 3,5	GT1PM-NRS03035	1495,4	224,3	135	113	27	86	243	44	66	3,0	1,0
	5/8" - 11UN	GT1P-NRS0625U11	1495,4	224,3	135	113	27	86	243	44	57	3,0	1,6
	3/4" - 10UN	GT1P-NRS0750U10	1495,4	224,3	135	113	27	86	243	44	59	3,0	1,4
	7/8" - 9UN	GT1P-NRS0875U09	1495,4	224,3	135	113	27	86	243	44	62	3,0	1,3
1" - 8UN	GT1P-NRS1000U08	1495,4	224,3	135	113	27	86	243	44	64	3,0	1,2	
1 1/8" - 8UN	GT1P-NRS1125U08	1495,4	224,3	135	113	27	86	243	44	66	3,0	1,0	
GT2-LCB	M30 x 3,5	GT2PM-NRS03035	2677,2	401,5	136	111	35	107	226	41	75	4,1	2,6
	M33 x 3,5	GT2PM-NRS03335	2677,2	401,5	136	111	35	107	226	41	76	4,1	2,4
	M36 x 4	GT2PM-NRS03640	2677,2	401,5	136	111	35	107	226	41	79	4,1	2,2
	M39 x 4	GT2PM-NRS03940	2677,2	401,5	136	111	35	107	226	41	82	4,1	1,9
	1 1/8" - 8UN	GT2P-NRS1125U08	2677,2	401,5	136	111	35	107	226	41	74	4,1	2,6
	1 1/4" - 8UN	GT2P-NRS1250U08	2677,2	401,5	136	111	35	107	226	41	76	4,1	2,4
	1 3/8" - 8UN	GT2P-NRS1375U08	2677,2	401,5	136	111	35	107	226	41	79	4,1	2,2
	1 1/2" - 8UN	GT2P-NRS1500U08	2677,2	401,5	136	111	35	107	226	41	82	4,1	2,0

* Load Cell with tommy bar.

Topside Bolt Tensioners



Thread and Pitch Sizes

Contact Enerpac for different thread or pitch sizes. Alternative size adaptor kits can be supplied upon request.

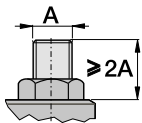

Minimum Stud Protrusion

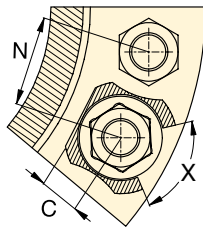

X = Minimum socket rotation 60°

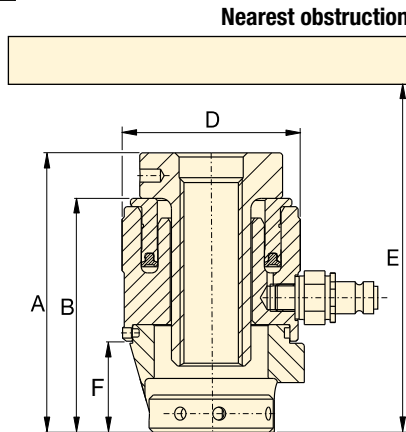

GT Series



Bolt Range:

M16 - M105, 5/8" - 4"

Maximum Load Capacity at 1500 bar:

224 - 3958 kN

Stroke:

10 mm

Maximum Operating Pressure:

1500 bar

Load Cell * and Bridge Model Number	Thread Size	Adaptor Kit Model Number	Cylinder Effective Area (mm ²)	Maximum Load Capacity (kN)	Dimensions (mm)							Load Cell and Bridge Weight (kg)	Adaptor Kit Weight (kg)
					A	B	C	D	E min.	F	N min.		
GT3-LCB	M39 x 4	GT3PM-NRS03940	5127,1	768,9	160	126	46	138	256	56	96	7,0	5,7
	M42 x 4,5	GT3PM-NRS04245	5127,1	768,9	160	126	46	138	256	56	98	7,0	5,4
	M45 x 4,5	GT3PM-NRS04545	5127,1	768,9	160	126	46	138	256	56	101	7,0	5,0
	M48 x 5	GT3PM-NRS04850	5127,1	768,9	160	126	46	138	256	56	104	7,0	4,7
	M52 x 5	GT3PM-NRS05250	5127,1	768,9	160	126	46	138	256	56	107	7,0	4,2
	1 1/2" - 8UN	GT3P-NRS1500U08	5127,1	768,9	160	126	46	138	256	56	95	7,0	5,7
	1 5/8" - 8UN	GT3P-NRS1625U08	5127,1	768,9	160	126	46	138	256	56	98	7,0	5,3
	1 3/4" - 8UN	GT3P-NRS1750U08	5127,1	768,9	160	126	46	138	256	56	101	7,0	5,0
GT4-LCB	1 7/8" - 8UN	GT3P-NRS1875U08	5127,1	768,9	160	126	46	138	256	56	104	7,0	4,6
	2" - 8UN	GT3P-NRS2000U08	5127,1	768,9	160	126	46	138	256	56	106	7,0	4,2
	M52 x 5	GT4PM-NRS05250	9782,1	1466,9	180	141	62	174	281	71	121	12,2	10,7
	M56 x 5,5	GT4PM-NRS05655	9782,1	1466,9	180	141	62	174	281	71	124	12,2	10,1
	M60 x 5,5	GT4PM-NRS06055	9782,1	1466,9	180	141	62	174	281	71	127	12,2	9,4
	M64 x 6	GT4PM-NRS06460	9782,1	1466,9	180	141	62	174	281	71	129	12,2	8,8
	M68 x 6	GT4PM-NRS06860	9782,1	1466,9	180	141	62	174	281	71	132	12,2	8,1
	2" - 8UN	GT4P-NRS2000U08	9782,1	1466,9	180	141	62	174	281	71	120	12,2	10,7
GT5-LCB	2 1/4" - 8UN	GT4P-NRS2250U08	9782,1	1466,9	180	141	62	174	281	71	126	12,2	9,7
	2 1/2" - 8UN	GT4P-NRS2500U08	9782,1	1466,9	180	141	62	174	281	71	132	12,2	8,5
	M68 x 6	GT5PM-NRS06860	15079,7	2261,4	202	157	78	210	302	86	148	18,7	17,3
	M72 x 6	GT5PM-NRS07260	15079,7	2261,4	202	157	78	210	302	86	149	18,7	16,4
	M76 x 6	GT5PM-NRS07660	15079,7	2261,4	202	157	78	210	302	86	152	18,7	15,5
	M80 x 6	GT5PM-NRS08060	15079,7	2261,4	202	157	78	210	302	86	155	18,7	14,6
	2 1/2" - 8UN	GT5P-NRS2500U08	15079,7	2261,4	202	157	78	210	302	86	148	18,7	17,8
	2 3/4" - 8UN	GT5P-NRS2750U08	15079,7	2261,4	202	157	78	210	302	86	153	18,7	16,3
GT6-LCB	3" - 8UN	GT5P-NRS3000U08	15079,7	2261,4	202	157	78	210	302	86	158	18,7	14,8
	3 1/4" - 8UN	GT5P-NRS3250U08	15079,7	2261,4	202	157	78	210	302	86	161	18,7	13,1
	M80 x 6	GT6PM-NRS08060	18972,1	2845,1	219	173	82	240	323	95	167	27,8	22,3
	M85 x 6	GT6PM-NRS08560	18972,1	2845,1	219	173	82	240	323	95	170	27,8	21,0
	M90 x 6	GT6PM-NRS09060	18972,1	2845,1	219	173	82	240	323	95	175	27,8	19,4
	M95 x 6	GT6PM-NRS09560	18972,1	2845,1	219	173	82	240	323	95	179	27,8	18,0
	3 1/4" - 8UN	GT6P-NRS3250U08	18972,1	2845,1	219	173	82	240	323	95	173	27,8	20,7
GT7-LCB	3 1/2" - 8UN	GT6P-NRS3500U08	18972,1	2845,1	219	173	82	240	323	95	181	27,8	18,8
	3 3/4" - 8UN	GT6P-NRS3750U08	18972,1	2845,1	219	173	82	240	323	95	188	27,8	16,8
	M100 x 6	GT7PM-NRS10060	26389,4	3958,4	243	182	89	277	332	110	196	38,2	28,5
GT7-LCB	M105 x 6	GT7PM-NRS10560	26389,4	3958,4	243	182	89	277	332	110	199	38,2	27,3
	4" - 8UN	GT7P-NRS4000U08	26389,4	3958,4	243	182	89	277	332	110	204	38,2	27,3

* Load Cell with tommy bar.

▼ Aquajack® Tensioner EAJ2LC with Quick Fastening Nut



- Compact design
- Long piston stroke
- Misalignment compensation
- Quick, simple hose connection
- Visible piston stroke indication
- 'No spill' overstroke elimination
- Quick fastening or solid reaction nut.

▼ Guaranteed to save time and increase efficiency, Aquajack® tensioners improve diver safety, productivity and reduce diver fatigue.



The most cost effective solution to subsea bolt or stud tightening



Quick Fastening Nut Design

Easily positioned in poor visibility conditions, Aquajack® subsea tensioners feature a compact design and long piston stroke.

The unique Split Nut® design of these tools allows rapid application to long bolts and damaged threads, and rapid tool removal.



No Oil Spillage or Over-Stroking

Innovative tool design ensures maximum tool strokes can be used without over stroking the piston or oil spillage. Guaranteed to save time and increase efficiency, Aquajack® subsea tensioners improve diver safety, productivity and reduce diver fatigue.

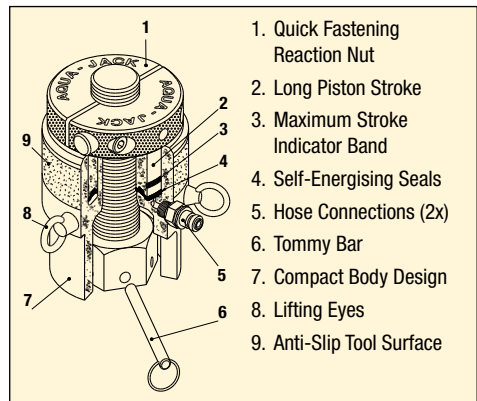

Hose Reels and Stand

Stainless steel stand with 1500 bar hoses from 30 upto 270 metres lengths. All hose reels are built up with multiple 30 metre length hoses.

Aquajack® Subsea Tensioners

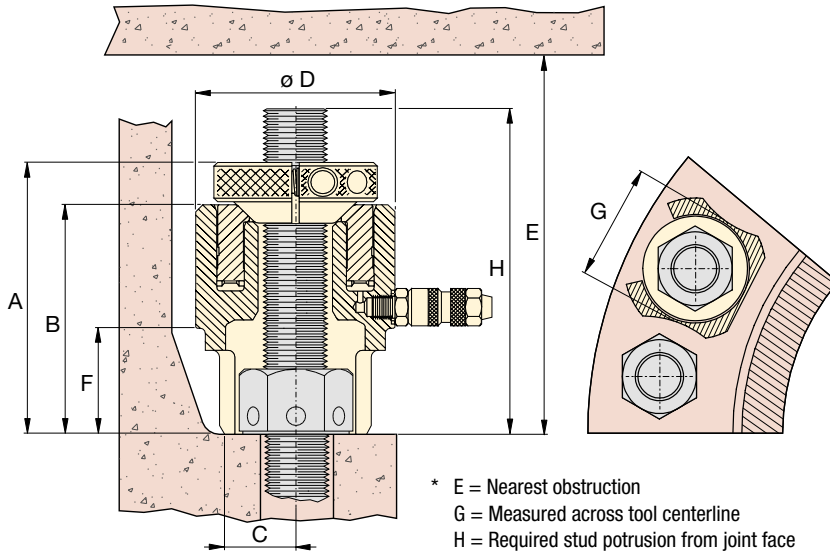

EAJ Series



Bolt Range:

M20 - M90 | 3/4 - 3 1/2 inch

Maximum Load Capacity:

151,3 - 2320,9 kN

Maximum Operating Pressure:

1500 bar

Load Cell Model Number **	Thread Size	Quick Fastening Nut Model Number	Cylinder Effective Area (mm ²)	Maximum Load Capacity (kN)	Stroke (mm)	Dimensions (mm)								Tool Weight (kg)
						A	B	C	D	E*	F	G*	H*	
EAJ1LC	3/4" - 10 UN	EAJ1QFN0750U10	1008,7	151,3	20	114	91	19	66	217	35	53	119	1,5
	7/8" - 9 UN	EAJ1QFN0875U09												
	M20 x 2,5	EAJ1QFNM02025												
	M22 x 2,5	EAJ1QFNM02225												
EAJ2LC	1" - 8 UN	EAJ2QFN1000U08	1658,4	248,7	30	147	120	25	82	289	50	62	152	3,0
	M24 x 2,5	EAJ2QFNM02425												
	M27 x 3,0	EAJ2QFNM02730												
	1 1/8" - 8 UN	EAJ2QFN1125U08												
EAJ3LC	M30 x 3,5	EAJ2QFNM03035	2524,3	378,6	30	158	131	28	98	307	58	78	163	4,5
	1 1/4" 8 UN	EAJ3QFN1250U08												
	M33 x 3,5	EAJ3QFNM03335												
	1 3/8" - 8 UN	EAJ3QFN1375U08												
EAJ4LC	M36 x 3,5	EAJ3QFNM03635	3686,7	553,0	30	171	136	33	114	319	63	91	176	6,0
	1 1/2" - 8 UN	EAJ4QFN1500U08												
	M39 x 4,0	EAJ4QFNM03940												
	1 5/8" - 8 UN	EAJ4QFN1625U08												
EAJ5LC	M42 x 4,5	EAJ4QFNM04245	5908,7	886,3	30	184	146	40	139	342	70	114	189	9,0
	1 3/4" - 8 UN	EAJ5QFN1750U08												
	M45 x 4,5	EAJ5QFNM04545												
	1 7/8" - 8 UN	EAJ5QFN1875U08												
	M48 x 5,0	EAJ5QFNM04850												
EAJ6LC	2" - 8 UN	EAJ5QFN2000U08	8312,8	1246,9	30	201	161	49	164	367	82	138	206	13,0
	M52 x 5,0	EAJ5QFNM05250												
	M56 x 5,5	EAJ6QFNM05655												
	2 1/4" - 8 UN	EAJ6QFN2250U08												
	M60 x 5,5	EAJ6QFNM06055												
EAJ7LC	2 1/2" - 8 UN	EAJ6QFN2500U08	12.369,0	1855,4	30	230	178	75	192	400	95	154	235	19,0
	M64 x 6,0	EAJ6QFNM06460												
	M68 x 6,0	EAJ7QFNM06860												
	2 3/4" - 8 UN	EAJ7QFN2750U08												
EAJ8LC	M72 x 6,0	EAJ7QFNM07260	15.473,0	2320,9	30	247	193	68	216	412	109	182	252	24,5
	M76 x 6,0	EAJ7QFNM07660												
	3" - 8 UN	EAJ7QFN3000U08												
	M80 x 6,0	EAJ8QFNM08060												
	3 1/4" - 8 UN	EAJ8QFN3250U08												
M85 x 6,0	EAJ8QFNM08560													
M90 x 6,0	EAJ8QFNM09060													
M90 x 6,0	EAJ8QFN3500U08													

** Tommy Bar included with Load Cell.

▼ PGT-Series Single Stage and Double Deck Tensioners



High Precision, Low Maintenance



Tensioning Pumps

Electric, pneumatic and manual high-pressure tensioning pumps are available for use with Enerpac hydraulic tensioners.



Hoses and Fittings

High-pressure hoses and fittings for use with Enerpac tensioning systems are available.

Page: 91

- PGT-Series Bolt Tensioners are designed for critical fastening applications in wind, steam and gas turbines
- A broad range of single stage and double deck tensioners provide high performance in tight spaces associated with Power Generation applications
- PGT-Series Bolt Tensioners are loaded with performance enhancing features such as Auto-Retract Pistons, Cycle Counters and a premium coating to offer the ultimate in efficiency, durability and ease of use.

Description	PGTS Single Stage	PGTD Double Deck
Auto-Retract Piston	✓	✓
Zinc Coating	✓	✓
Geared Nut-Rundown	✓	✓
Over-stroke Indicator	✓	✓
Over-stroke Preventer	✓	✓
Single Male Fitting	✓	✓
Swivel Manifold	+	+
Cycle Counter	-	+

✓ = Standard on tensioner

⊕ = Possible option

- = Option not available

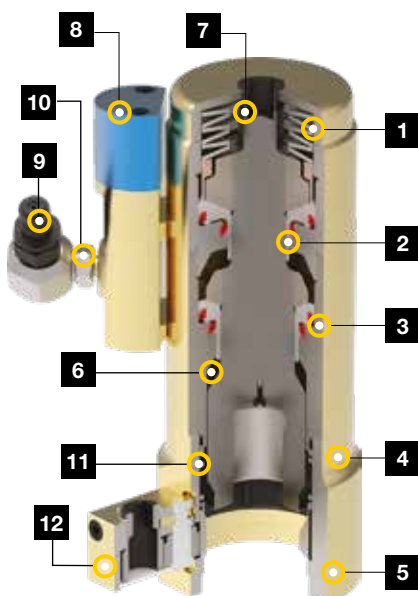

1. **Auto-retract piston:** Simplifies use and improves speed of operation.
2. **Long-life puller:** For maximum durability.
3. **Long-life seals:** For maximum durability and extended service life intervals.
4. **Corrosion protection:** Zinc coating provides best-in-class corrosion resistance.
5. **Interchangeable bridge:** For optimal application fit.
6. **Over-stroke preventer:** Mechanically prevents over-stroke, extending cylinder life.
7. **Over-stroke indicator:** Extends cylinder life by helping to prevent over-stroking of cylinder.
8. **Optional counter:** Helps indicate when maintenance is due to maximize uptime.
9. **Quick-disconnect coupler:** For safe, simple hydraulic connection.
10. **Optional 360° swivel:** available for additional hose positioning flexibility.
11. **Spring-loaded nut engagement:** Keeps socket positioned on nut for faster and easier seating process.
12. **Auto-engage nut rundown:** For rapid and accurate seating of nuts.

▲ The model above illustrates a typical tool configuration. Actual model configurations vary.

Power Generation Bolt Tensioners



Options

Fitting Type

SW = Swivel manifold with single male fitting
Example: **PGTS2436SW**

Cycle-Counter

C = Cycle Counter (not available on PGTS-models)
Example: **PGTD3655SWC**

- ① Puller bar square drive
- ② Swivel manifold with single male fitting
- ③ Single male fitting
- ④ Nut run down gear box

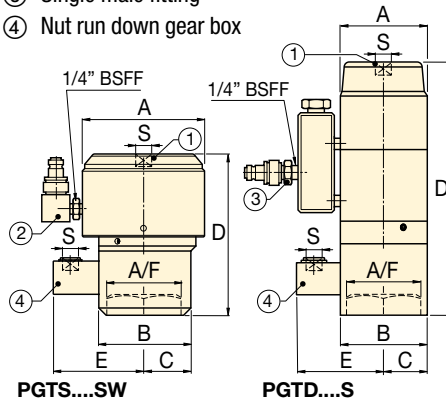

PGT Series



Bolt Range:

M20 - M72

Maximum Load Capacity:

203,7 - 2969,6 kN

Maximum Operating Pressure ¹⁾:

1350 - 1500 bar

¹⁾ Max. pressure varies, see specifications table for details.

Tensioner Type	Thread Diameter (mm)	Model Number with single male fitting	Nut Size A/F (mm)	Maximum Pressure (bar)	Hydraulic Pressure Area (mm ²)	Maximum Load Capacity (kN)	Stroke (mm)	Dimensions (mm)						Bolt Potrusion (mm)		
								A	B	C	D	E	S* (inch)			
Single Stage	M20 x 2,5	PGTS2030S	30	1500	1358	203,7	7,0	64	64	32	81	78	3/8	2,0	44	55
	M24 x 3,0	PGTS2436S	36	1500	1947	292,1	7,0	77	77	31	98	81	3/8	2,9	49	62
	M27 x 3,0	PGTS2742S	42	1500	2646	396,9	8,0	92	75	34	129	83	3/8	4,8	60	70
	M30 x 3,5	PGTS3046S	46	1500	3204	480,7	8,0	99	85	38	134	88	3/8	5,8	68	73
	M33 x 3,5	PGTS3350S	50	1500	3960	594,0	8,0	106	90	40	142	90	3/8	6,8	75	100
	M36 x 4,0	PGTS3655S	55	1500	4467	670,1	9,0	111	90	56	128	95	1/2	6,4	71	95
	M39 x 4,0	PGTS3960S	60	1500	5561	834,1	10,0	123,5	104	46	160	96	3/8	9,8	89	115
	M42 x 4,5	PGTS4265S	65	1500	6259	938,8	10,0	134	115	67	177	99	1/2	9,5	79	115
	M45 x 4,5	PGTS4570S	70	1500	7505	1125,8	10,0	143	119	53	168	102	3/8	13,2	98	116
	M48 x 5,0	PGTS4875S	75	1500	8390	1258,4	10,0	152	125	56	158	106	3/8	13,3	103	119
	M52 x 5,0	PGTS5280S	80	1500	10.094	1514,1	10,0	165	134	59	171	108	3/8	17,9	106	118
	M56 x 5,5	PGTS5685S	85	1500	11.663	1749,5	10,0	177	142	62	170	112	3/8	20,4	116	128
	M60 x 5,5	PGTS6090S	90	1500	13.474	2021,2	10,0	190	152	66	186	115	3/8	24,8	123,5	137
	M64 x 6,0	PGTS6495S	95	1500	15.315	2297,3	10,0	200	159	69	207	118	1/2	30,7	137	150
M68 x 6,0	PGTS68100S	100	1500	17.493	2623,9	10,0	213,5	169	73	206	123	1/2	34,3	136	148	
M72 x 6,0	PGTS72105S	105	1500	19.797	2969,6	10,0	225	178	76	223	126	1/2	40,3	151	167	
Double Deck	M24 x 3,0	PGTD2436S	36	1350	2293	309,6	6,0	61,5	77	31	185	81	3/8	4,6	53	59,5
	M27 x 3,0	PGTD2742S	42	1350	2939	396,8	6,0	68	75	34	196	83,4	3/8	5,3	60	68
	M30 x 3,5	PGTD3046S	46	1350	3426	462,6	7,0	73	85	37	195	88	3/8	5,8	60	70
	M33 x 3,5	PGTD3350S	50	1350	4272	576,7	7,0	78	77	38,5	208	90	3/8	6,7	65	77
	M36 x 4,0	PGTD3655S	55	1350	4995	674,3	8,0	84	83	41	218	93	1/2	7,7	70	87
	M39 x 4,0	PGTD3960S	60	1350	6260	845,0	10,0	95	104	48	266	96	3/8	12,5	84	93
	M42 x 4,5	PGTD4265S	65	1350	6865	926,8	10,0	98	104	52	248,4	99	1/2	11,4	82	91
	M45 x 4,5	PGTD4570S	70	1350	8339	1125,8	10,0	108	119	53	294	104	3/8	17,7	97	107
	M48 x 5,0	PGTD4875S	75	1350	9430	1273,1	10,0	115	125	57,5	304	106	3/8	20,1	103	113
	M52 x 5,0	PGTD5280S	80	1350	11.288	1523,8	10,0	124	134	61	328	108	3/8	26,1	110	125,5
	M56 x 5,5	PGTD5685S	85	1350	12.942	1747,1	10,0	132	142	65	346	112	3/8	30,0	117	132,5
	M60 x 5,5	PGTD6090S	90	1350	15.032	2029,3	10,0	141	152	70,5	372	115	3/8	37,2	125	143
	M64 x 6,0	PGTD6495S	95	1350	17.123	2311,6	10,0	151	159	76	386	119	1/2	43,0	133	152,5
	M68 x 6,0	PGTD68100S	100	1350	19.514	2634,4	10,0	160	170	80	398	123	1/2	49,5	138	160
M72 x 6,0	PGTD72105S	105	1350	21.977	2966,9	10,0	171	177	88,5	429	126	1/2	60,1	146	171	

* Dimension S = Square Drive of Puller Bar and Gear Box.

▼ FTR-Series, Foundation Bolt Tensioners Round



- **FTR-Series Foundation Bolt Tensioners provide fast, accurate and easy tightening of external or internal-ring wind tower foundations**
- **Standard models are available for 75, 150 ksi and metric style Williams, Dyson and Macalloy® bar types**
- **Long-stroke options accelerate process with single-pull tensioning.**

High Precision, Low Maintenance



FTR-Series Foundation Bolt Tensioners

FTR-Series Foundation Bolt Tensioners are designed specifically for tensioning wind tower foundation bolts. These tensioners provide the speed and precision required by this critical application. Potential thread fit problems are eliminated through the use of existing rebar hex nuts as a reaction point.

The FTR-Series includes long-stroke models, which provide greater speed and ease of use by enabling applications to be completed in a single pull.

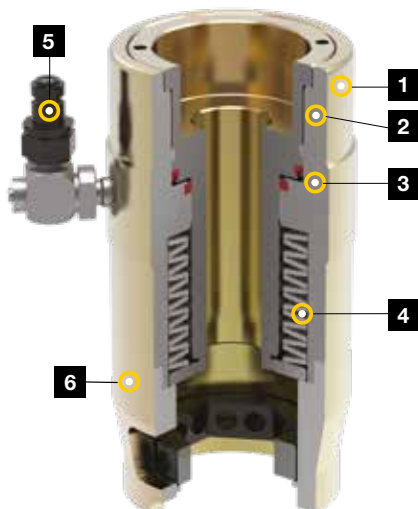

1. **Corrosion protection:** Zinc coating provides best-in-class corrosion resistance.
2. **Over-stroke indicator:** Extends life by helping to prevent over-stroking of cylinder.
3. **Long-life seals:** For maximum durability and extended service life intervals.
4. **Auto-retract piston:** Simplifies use and improves speed of operation.
5. **Quick-disconnect coupler:** For safe, simple hydraulic connection. Optional 360° swivel available for additional hose positioning flexibility.
6. **Interchangeable bridge:** For optimal application fit.

▼ *FTR-Series Foundation Bolt Tensioner. Manual wrench (not included) required to apply up to 30 Nm of torque during installation of models that feature run down gears.*



Foundation Bolt Tensioners

▼ This is how a FTR-Series Foundation Bolt Tensioner model number is built up:



1 Product Type

FTR = Foundation Tensioner, Round

2 Bar Grade

75 = 75 ksi
150 = 150 ksi
 (or metric designation)

3 Bar Size Designation

Example
14 = No. 14 bar size

4 Maximum Stroke

Example:
20 = 20 mm max. stroke

5 Fitting Type

SW = Includes swivel manifold with single male fitting
 single male fitting

6 Run Down Gear

G = Includes Nut Run Down Gear
 * available in select models

FTR Series



Maximum Load Capacity:

2736 kN

Maximum Operating Pressure ¹⁾:

1500 bar

¹⁾ Max. pressure varies, see specifications table for details.



Tensioning Pumps

Electric, pneumatic and manual high-pressure tensioning pumps are available for use with Enerpac hydraulic tensioners.



Hoses and Fittings

High-pressure hoses and fittings for use with Enerpac tensioning systems are available.

Page: 91

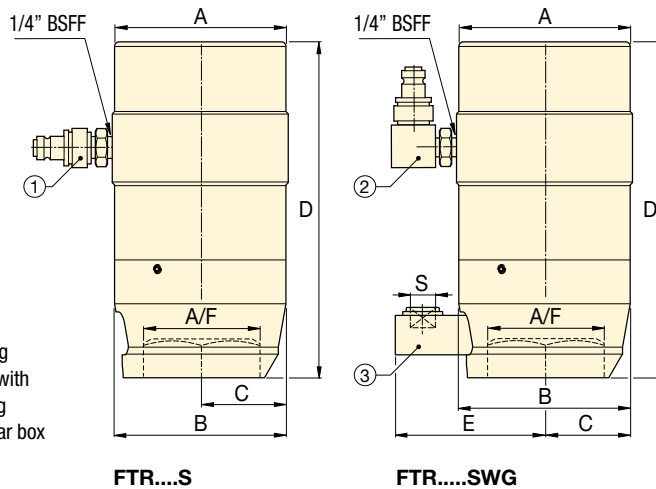

- ① Single male fitting
- ② Swivel manifold with single male fitting
- ③ Nut run down gear box

▼ SPECIFICATION TABLE

Bar Grade	Bolt Diameter		Bar Size Designation	Model Number with single male fitting	Nut Size A/F	Max. Pressure	Hydraulic Pressure Area	Max. Load Capacity	Stroke	Dimensions (mm)					Minimum Bolt Potrusion	
	(mm)	(inch)								A	B	C	D	E		(kg)
75 ksi	35	1.38	#10	FTR751010S	51	1200	3134	376,1	10,0	99	88,5	44,3	163	–	5,8	200
	35	1.38	#10	FTR751025S	51	1200	3123	374,8	25,0	115	102	42	220	–	10,9	250
	38	1.50	#11	FTR751110S	57	1500	3134	470,1	10,0	99	98	38	178	–	5,5	220
	38	1.50	#11	FTR751125SG	57	1500	3123	468,5	25,0	115	102	51	226	96	11,5	260
	48	1.88	#14	FTR751420S	70	1170	6093	712,9	20,0	132	132	66	268	–	18,2	315
150 ksi	37	1.44	1.25	FTR15012510S	57	1170	5383	629,8	10,0	111	110	40	178	–	8,2	220
	40	1.56	1.37	FTR15013810S	64	1500	5383	807,5	10,0	111	110	38	178	–	8,1	225
	70	2.75	2.50	FTR15025025S	108	1500	18.238	2736,0	25,4	215	212	86	348	–	58,0	450
10.9	36	1.42	36	FTR1093610SG	60	1500	3820	573,0	10,0	102	99	40	176	95	8,6	195

Gear box square drive dimension S = 1/2 inch.

▼ FTE-Series, Foundation Bolt Tensioner Elliptical



- **FTE-Series Foundation Bolt Tensioners provide fast and accurate performance in difficult, narrow access foundation tensioning applications**
- **Standard models are available for 75, 150 ksi and metric style Williams, Dyson and Macalloy® bar types**
- **Ideal universal solution that fits both standard and narrow access applications.**

High Precision, Low Maintenance



FTE-Series, Foundation Bolt Tensioners

Similar to Standard Foundation Tensioners, Elliptical tensioners were designed specifically for foundation fastening applications on wind towers, and utilize the existing hex nut as a reaction point in order to eliminate thread fit misalignment.

Unlike standard FTR-Series Tensioners, the FTE-Series Tensioners feature an elliptical geometry, which enables fit in narrow access foundation applications, without reducing load capabilities.

Operators may access the nut with a Tommy bar rather than employing the use of an offset rundown gear.

Elliptical tensioners are ideal for close clearance applications, or as a universal tool that will work in nearly any foundation application, whether standard or narrow access.

-
1. **Maximum stroke Indicator:** Extends life by helping to prevent over-stroking of cylinder.
 2. **Long-life seals:** For maximum durability and extended service life intervals.
 3. **Auto-retract piston:** Simplifies use and improves speed of operation.
 4. **Elliptical form:** Provides access to close clearance applications.
 5. **Corrosion protection:** Zinc coating provides best-in-class corrosion resistance.
 6. **Quick-disconnect coupler:** (*not shown*) For safe, simple hydraulic connection. Optional 360° swivel available for additional hose positioning flexibility.

▼ *FTE-Series, Foundation Bolt Tensioner, designed to fit both standard and narrow access foundation applications.*



Foundation Bolt Tensioners, Elliptical

▼ This is how a FTE-Series Foundation Bolt Tensioner model number is built up:



1 Product Type

FTE = Foundation Tensioner, Elliptical

2 Bar Grade

75 = 75 ksi
150 = 150 ksi
 (or metric designation)

3 Bar Size Designation

Example
10 = No. 10 bar size

4 Fitting Type

SW = Includes swivel manifold with single male fitting

FTE Series



Maximum Load Capacity:

761,1 kN

Maximum Operating Pressure ¹⁾:

1500 bar

¹⁾ Max. pressure varies, see specifications table for details.



Tensioning Pumps

Electric, pneumatic and manual high-pressure tensioning pumps are available for use with Enerpac hydraulic tensioners.



Hoses and Fittings

High-pressure hoses and fittings for use with Enerpac tensioning systems are available.

Page: 91

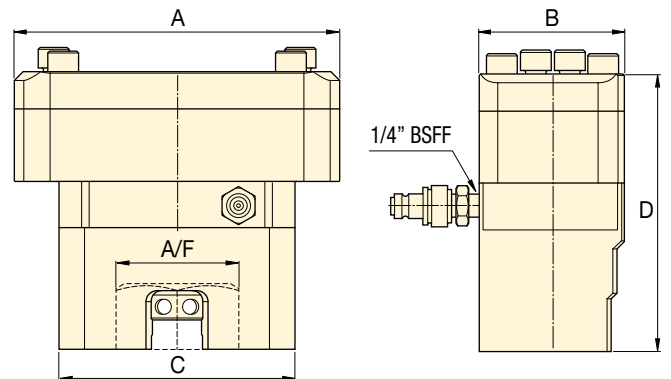

▼ SPECIFICATION TABLE

Bar Grade	Bolt Diameter		Bar Size Designation	Model Number with single male fitting	Nut Size A/F	Max. Pressure	Hydraulic Pressure Area	Max. Load Capacity	Stroke	Dimensions (mm)				Minimum Bolt Potrusion	
	(mm)	(inch)								A	B	C	D		
75 ksi	35	1.38	#10	FTE7510S	51	1200	3108	373,0	10,0	170	82	142	147,5	8,3	200
	38	1.50	#11	FTE7511S	57	1500	3108	466,2	10,0	170	82	142	147,5	8,3	200
150 ksi	40	1.56	1.375	FTE150138S	64	1500	5074	761,1	10,0	222	99	161	203,4	18,5	230
	37	1.44	1.250	FTE150125S	57	1200	5074	608,9	10,0	222	99	161	203,4	18,9	240
8.8	36	1.42	36	FTE8836S	60	1500	3108	466,2	10,0	142	82	142	147,5	9,7	180

Tensioning every single stud in a joint simultaneously



▲ *Multi Stud Tensioning Set-Up.*

MULTI STUD TENSIONERS

Enerpac Multi Stud Tensioning (MST) systems are capable of tensioning every single stud in a joint simultaneously. By applying a predictable and accurate pre-load to all studs, problems associated with conventional bolt tightening techniques are avoided. Typical Enerpac Multi Stud Tensioning applications include:

Manway, Hand Hole & Inspection Covers

MST systems are the fastest and most accurate means of loosening and tightening studs on Primary & Secondary Manway Covers, Hand-Hole and Inspection Ports in nuclear facilities. Using special ram areas and strong lightweight materials, the MST's reduce bolting time by as much as 75%.

Coolant Pump

A custom slimline tensioning system for a Nuclear Reactor Coolant Pump, using six equally spaced tensioners and tightening studs in four passes, has reduced bolting times by 25% and significantly increased tensioning accuracy.

Wind Turbine Blade Assembly

Using an Enerpac MST has allowed wind turbine blade assembly times to be reduced by approx. 65% while bolt load accuracy and consistency have improved, resulting in better joint life and reduced maintenance requirements. The MST, comprising four tool segments, is capable of simultaneously tensioning up to 88 bolts connecting a 125 ft long blade to a bearing slew ring.

MST - Multi Stud Tensioners

This tool can be custom-designed, and built, for virtually any nuclear facility. We specialise in addressing difficult projects that demand accurate loads within tight space envelopes, while also seeking ease of operation and performance.

- Designed in segments enabling the operator to easily and quickly connect each segment to the joint and link together to provide simultaneous loading.
- Very accurate and fast closure system for large tensioning applications on pumps, valves, and steam-generators, for example.
- For ease of handling on-site, Enerpac MST systems can be supplied with an integral lifting frame and trolley.



▲ *Multi Stud Tensioner.*



▲ *Multi Stud Tensioning application.*

A simple and effective method of tensioning large bolts in difficult to access areas



▲ Tensioning with hydraulic nuts.

HYDRAULIC NUTS

Enerpac hydraulic nuts are used in many process-critical bolting applications where the ease of installation and manpower time savings are substantial and on-going. Moreover, they eliminate many of the uncertainties of torque arising from friction, point loading and load scatter.

Enerpac Hydraulic Nuts are a simple and effective method of tensioning large bolts in difficult to access areas with insufficient space for standard tensioners. Typically used when installing and maintaining bolting systems, hydraulic nuts can replace both conventional hexagon nuts and standard round nuts providing a high and predictable degree of tensioning accuracy.

Threaded directly onto the stud, Enerpac hydraulic nuts apply a direct axial elongation by means of hydraulic force generated via the nut's integral hydraulic cylinder. The nut is held in place either by means of a top or bottom load retaining collar externally located on the nut or by the insertion of mechanical shims. Enerpac hydraulic nuts can be retrofitted to existing plant providing an accurate solution to mechanical jointing problems.

Benefits of Enerpac Hydraulic Nuts

- Highly Accurate & Repeatable Bolt Loads
- Ideal where space limitations prevent use of standard detachable tensioners
- Direct Axial Loading - No nut rotation required
- Multiple Nuts can be connected and tightened / loosened simultaneously
- Eliminates issues with Friction
- Substantial time savings due to the quick set-up and hydraulic nuts remaining in-situ
- No stud or flange damage (Galling, Seizure)
- No need to change joint hardware – system works with existing studs
- Ideal when the tension in bolts needs to be checked regularly such as vibration loosening.

Enerpac hydraulic nut applications have included:

The Hydraulic Nut is a permanent fixture, replacing the conventional nut and retaining the high bolt load and extension in small space envelopes where there may not be sufficient space to use tensioners.

- Flange Clamps: Pipeline, Structural
- Turbines: Gas, Wind, Steam
- Pressure & Reactor Vessels
- Diesel Engines
- Nuclear Applications: Steam Generators
- Hydraulic and Mechanical Presses
- Heat Exchangers
- Pipeline Flanges, Valves and Control Systems
- Valves & Pumps
- Cranes – Slew Ring Bolts, Tower Cranes
- Shaft Couplings
- Mining: Grinders, Cutters, Earth Moving Equipment.



▲ Hydraulic nuts on a diesel engine.

▼ HPT1500



HPT Series

Reservoir Capacity:

2,5 litres

Flow at Rated Pressure:

0,61 cm³/stroke

Maximum Operating Pressure:

1500 bar



Applications

The hand pump is ideally suited for use with hydraulic bolt tensioning tools and hydraulic nuts.

Page: 76

- Lightweight and portable high-pressure hand pump
- Two-speed operation displaces a larger volume of oil per stroke, reducing cycle times for many testing applications
- Includes a pressure gauge and coupler for direct connection to Enerpac Bolt Tensioners
- Integrated relief valve set at 1500 bar.



Ultra-high pressure

This pump operates at ultra-high pressure, use only the specified fittings and hoses designed for these pressures.

Page: 93



Bolt Tensioning Theory

See more on tensioning operation and procedures in our "Yellow Pages".

Page: 140



Bolting Integrity Software

The software offers Tool selection, Bolt Load calculations and Tool pressure settings, as well as, a combined Application data sheet and Joint completion report. Custom Joint information can also be entered.

Page: 142

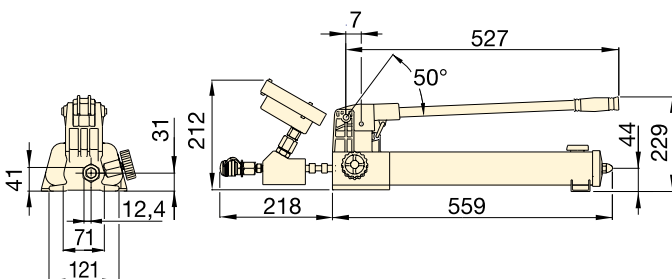

1500 BAR ULTRA-HIGH PRESSURE PUMP

Pump Type	Useable Oil Capacity (litres)	Model Number	Pressure Rating (bar)		Oil Displacement per Stroke (cm ³)		High Pressure Oil Port with female coupler	(kg)
			1st stage	2nd stage	1st stage	2nd stage		
Two Speed	2,54	HPT1500	14	1500	16,22	0,61	1/4" BSPP + BR150	9,0

Ultra-High Pressure Hoses & Couplers

- **Hose Reel and Stand:** Stainless steel stand with 1500 bar hoses from 30 upto 270 metres lengths
- All hose reels are built up with multiple 30 metres length hoses
- Wide offering of hoses and system components to complete your tensioning system
- Can be used for subsea fastening systems
- Hoses can be inter-connected in multi-tool set-ups using nipples, couplers, T-pieces and Y-Pipe assemblies.

HT, B Series



Hose Lengths:

1 - 30 metres

Hose Reel & Stand:

30 - 270 metres

Maximum Operating Pressure:

1500 bar

1500 BAR HOSE REEL & STANDS

Model Number		Stainless Steel Hose Reels with Stand (Hose with Female Half BR150 and Male Half BH150 couplers)
HT1500RS		Reel & Stand Assembly, No Fittings
HT1500HRS		Hose Reel & Stand, No Hose
HT1510HRS		Hose Reel & Stand, with 30 m hose
HT1520HRS		Hose Reel & Stand, with 60 m hose
HT1530HRS		Hose Reel & Stand, with 90 m hose
HT1540HRS		Hose Reel & Stand, with 120 m hose
HT1550HRS		Hose Reel & Stand, with 150 m hose
HT1560HRS		Hose Reel & Stand, with 180 m hose
HT1570HRS		Hose Reel & Stand, with 210 m hose
HT1590HRS		Hose Reel & Stand, with 270 m hose



▲ Inter-connected with HT-Series hoses Enerpac subsea tensioners apply uniform bolt load.

1500 BAR HOSES

Model Number		Hose End 1	Hose End 2	Length (m)
HT1503		1/4" BSPM 120° Cone	1/4" BSPM 120° Cone	1,0
HT1510		1/4" BSPM 120° Cone	1/4" BSPM 120° Cone	3,0
HT15100		1/4" BSPM 120° Cone	1/4" BSPM 120° Cone	30,0
HT1503HR *		BH150	BR150	1,0
HT1506HR *		BH150	BR150	1,8
HT1510HR *		BH150	BR150	3,0
HT1520HR *		BH150	BR150	6,1
HT15100HR *		BH150	BR150	30,0
HT1503RR *		BR150	BR150	1,0
HT1506RR *		BR150	BR150	1,8
HT1510RR *		BR150	BR150	3,0
HT1520RR *		BR150	BR150	6,1

* Includes dust caps.

H = Male Nipple (BH150); R = Female Coupling (BR150)

1500 BAR COUPLERS

Description (includes dust caps)		Complete Set	Female Half	Male Half
Quick Disconnect Coupler		B150	BR150	BH150
Quick Disconnect Coupler & Adaptor Kit		BW150AW	-	-
Quick Disconnect Blanking Coupler Set		B150B	BR150B	BH150B

1500 BAR T-PIECES

Model Number	shown HT15TPMMF	End 1	End 2	End 3
HT15TPMMF		1x BH150	1x BH150	1x BR150
HT15TPMMM		1x BH150	1x BH150	1x BH150

1500 BAR Y-PIPE ASSEMBLIES

Model Number	shown HT1506YTPMMF	End 1 Hose	End 2 Hose	End 3 T-Piece
HT1506YTPMMF		HT1506HR	HT1506HR	HT15TPMMF
HT1510YTPMMF		HT1510HR	HT1510HR	HT15TPMMF
HT1506YTPFMF		HT1506RR	HT1506RR	HT15TPMMM
HT1510YTPFMF		HT1510RR	HT1510RR	HT15TPMMM

Y-Pipe Assembly: 1+2 = adaptor; 3 = stainless steel T with 1/4" BSPM
4 = Male Nipple (BH150); 5 = Female Coupling (BR150); 6 = Hose

▼ ZUTP1500SE-H



- Solenoid-operated valve with 6 m pendant for remote control of valve and one-man operation
- Easily accessible manual override valve to release pressure if power is lost
- Safety relief valve limits output pressure
- Two-stage pump design provides high flow at low pressure for fast system fills and controlled flow at high pressure for accurate operation
- 1,25 kW heavy-duty universal motor provides the best performance-to-weight ratio
- Replaceable 10 micron reservoir breather and inline high pressure filter helps maintain oil cleanliness for optimum performance
- Panel-mounted 153 mm pressure gauge, with polycarbonate cover, is set into the protective metal shroud for improved visibility.



◀ *The ZUTP1500 pump is rugged, lightweight, compact for tight openings, and delivers hassle-free operation of bolt tensioning in remote locations with up to two times the speed of competitive pumps.*

Reliability, Power and Precision



Applications

The Enerpac ZUTP-Series electric pump is ideally suited for use with hydraulic bolt tensioning tools and hydraulic nuts. See our Bolting Tools catalogue and website.

Page: 76



Ultra-high pressure

This pump operates at ultra-high pressure, use only the specified fittings and hoses designed for these pressures.

Page: 93



Bolting Integrity Software

Visit www.enerpac.com to access our free on-line bolting software application and obtain information on tool selection, bolt load calculations and tool pressure settings.

A combined application data sheet and joint completion report is also available.

Page: 142

Electric Tensioning Pumps



ZUTP-Tensioning Pumps

The ZUTP-Series of pumps achieve high pressure without the need for an intensifier. This allows for low maintenance, resulting in less cost for the end-user.

ZUTP-S with Solenoid Valve

The ZUTP1500-S Series with pendant-operated solenoid valve is ideal for multiple bolt tensioning applications as it allows for single-person operation. The operator can pressurize and depressurize the tensioner directly from the pendant.

ZUTP Series



Reservoir Capacity:

4,0 litres

Flow at Rated Pressure:

0,33 l/min

Motor Size:

1,25 kW

Maximum Operating Pressure:

1500 bar

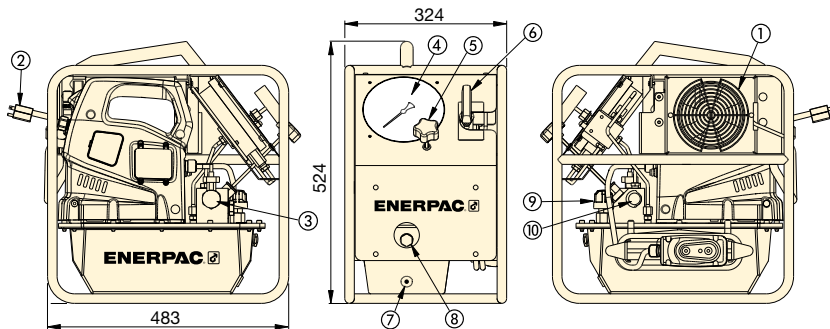

- ① Heat Exchanger (optional)
- ② Power Cord
- ③ Solenoid Dump Valve
- ④ Pressure Gauge
- ⑤ User Adjustable Relief Valve
- ⑥ Manual Release Valve
- ⑦ Oil Drain
- ⑧ Oil Level Sight Glass
- ⑨ Breather
- ⑩ Outlet Port with CEJN Coupler (116 Series)

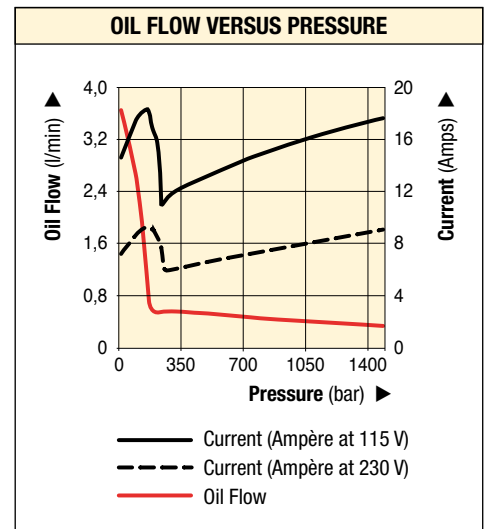

1500 bar HIGH PRESSURE PUMP

Pump Type	Useable Oil Capacity (litres)	Valve Type	Model Number ¹⁾	Pressure Rating (bar)	Output Flow Rate at 0 bar (l/min)	Output Flow Rate at 1500 bar (l/min)	Motor Electrical Specification (50 Hz)	Motor Size (kW)	Sound Level (dBA)	Weight (kg)
Two speed	4,0	Solenoid	ZUTP1500SB	1500	3,80	0,33	115 VAC, 1-ph	1,25	89	29,5
			ZUTP1500SE ²⁾				230 VAC, 1-ph ²⁾			
			ZUTP1500SI ³⁾				230 VAC, 1-ph ³⁾			
Two speed	4,0	Solenoid	ZUTP1500SB-H ⁴⁾	1500	3,80	0,33	115 VAC, 1-ph	1,25	89	34,0
			ZUTP1500SE-H ^{2) 4)}				230 VAC, 1-ph ²⁾			
			ZUTP1500SI-H ^{3) 4)}				230 VAC, 1-ph ³⁾			
Two speed	4,0	Jog	ZUTP1500B	1500	3,80	0,33	115 VAC, 1-ph	1,25	89	29,5
			ZUTP1500E ²⁾				230 VAC, 1-ph ²⁾			
			ZUTP1500I ³⁾				230 VAC, 1-ph ³⁾			

¹⁾ All models meet CE safety requirements and all TÜV requirements.

²⁾ European plug and CE EMC directive compliant.

³⁾ With NEMA 6-15 plug.

⁴⁾ H = with heat exchanger.

▼ ATP1500



- General purpose, high pressure air driven two speed pump unit for products requiring up to 1500 bar hydraulic pressure
- Compact, lightweight, rugged steel frame for protection and easy handling
- Prelubricated pump element, does not require an airline lubricator
- Easily adjustable output pressure control
- Integrated and protected easy to read glycerin filled gauge
- Safety relief valve limits output pressure.

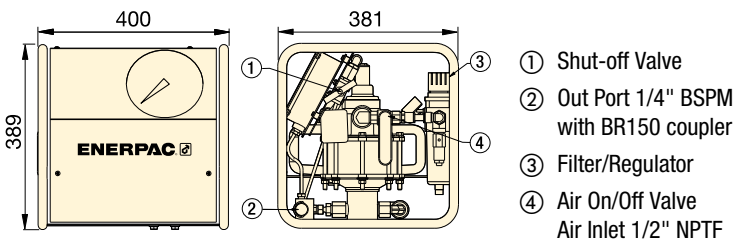

ATP Series

Reservoir Capacity:
3,8 litres

Flow at Rated Pressure:
0,07 l/min

Maximum Operating Pressure:
1500 bar



1500 bar Fittings and hoses

This pump operates at ultra-high pressure, use only the specified fittings and hoses designed for these pressures.

Page: 91



Applications

The ATP-pump is ideally suited for use with hydraulic bolt tensioning tools and hydraulic nuts.

Page: 74



ATEX Certified

The ATP-Pump is tested and certified according ATEX.



II 2 GD ck T4

Page: 130

OIL FLOW VERSUS PRESSURE

Flow (l/min) at 6,2 bar air input

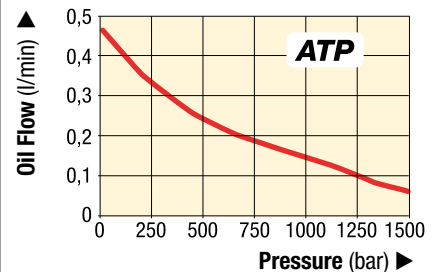

1500 bar HIGH PRESSURE AIR PUMP

Pump Type	Useable Oil Capacity (litres)	Pressure Rating (bar)	Model Number	Output Flow Rate at 0 bar (l/min)	Output Flow Rate at 1500 bar (l/min)	Air Pressure Range (bar)	Air Consumption (l/min)	Sound Level (dBA)	(kg)
Two-speed	3,8	1500	ATP1500	0,43	0,07	5,5 - 6,2	594	70	32

Power Box – Portable Tool Sets

▼ SCR154PGH



- Easy to carry sturdy tool box
- Complete and ready-to-use hydraulic sets
- Includes a single-acting cylinder, P392 two-speed lightweight hand pump, gauge adaptor assembly, 1,8 metre hose and couplers
- All components ship inside tool box as one package.

SC, SL, SR, SW Series

Capacity:

1 - 45 ton

Stroke:

11 - 156 mm







Maximum Operating Pressure:

700 bar



Gauge Adaptor Assembly

The portable Power Box Sets include 45 degree angled gauge adaptor assembly **GA45GC** for improved safe working conditions.

	Cylinder Model	Cylinder Stroke (mm)	Cylinder Capacity ton (kN)	 Weight (kg)	Power Box Model Number
	Lifting Wedge				
	LW16	21	16 (157)	9,0	SLW16PGH ²⁾
	Wedge Spread Cylinder				
	WR5	94 ¹⁾	1,0 (8,9)	12,0	SWR5PGH
	General Purpose Cylinders				
	RC102	54	10 (101)	12,3	SCR102PGH
	RC106	156	10 (101)	14,4	SCR106PGH
	RC154	101	15 (142)	15,0	SCR154PGH
	RC156	152	15 (142)	16,8	SCR156PGH
	Low-Height Cylinders				
	RCS101	38	10 (101)	14,1	SCL101PGH
	RCS201	45	20 (201)	15,0	SCL201PGH
	Flat-Jac® Cylinders				
	RSM100	11	10 (101)	11,4	SRS100PGH
	RSM200	11	20 (201)	13,1	SRS200PGH
	RSM300	13	30 (295)	14,5	SRS300PGH
	RSM500	16	45 (435)	16,8	SRS500PGH

¹⁾ Maximum spread of WR5.

²⁾ With P142 two-speed lightweight hand pump.

▼ The Power Box – the portable tool set, applicable everywhere.



▼ SCR1010H cylinder-pump set



The Quickest and Easiest Way to Start Working Right Away



Power Box

The portable tool box with hand pump, gauge adaptor assembly, hose and LW-, RC-, RCS, RSM- or WR-Serie cylinder.

Page: 95

- Optimum match of individual components
- All sets are ready-for-use
- Sets include 1,8 m safety hose and gauge with gauge adaptor
- All pumps are two-speed
- Choice between handpump, air driven foot pump or cordless (battery-powered) pump
- RC-Series, General Purpose Cylinders: for maximum versatility
- RCS-Series, Low-Height Cylinders: ideal where space is restricted
- RCH-Series, Hollow Plunger Cylinders: for pushing and pulling applications.

▼ Cylinder-Pump Sets – optimum match of components. The quickest and easiest way to start working right away.



1 Cylinder Selection	Set Capacity ton (kN)	Cylinder Model Number	Stroke (mm)	Collapsed Height (mm)
	5 (45)	RC55	127	215
		RC102	54	121
	10 (101)	RC106	156	247
		RC1010	257	349
		RC154	101	200
	15 (142)	RC156	152	271
		25 (232)	RC252	50
	RC254		102	215
	RC256		158	273
	RC2514		362	476
50 (498)	RC506	159	282	
	10 (101)	RCS101	38	88
	20 (201)	RCS201	45	98
	30 (295)	RCS302	62	117
	45 (435)	RCS502	60	122
	90 (887)	RCS1002	57	141
	13 (125)	RCH121	42	120
	20 (215)	RCH202	49	162
	30 (326)	RCH302	64	178
	60 (576)	RCH603	76	247
	95 (933)	RCH1003	76	254

Single-Acting Cylinder-Pump Sets

SET SELECTION:

- 1** Select the cylinder
- 2** Select the pump
- 3** Find the set model number in the gray matrix

SELECTION EXAMPLE

- Selected cylinder:**
- RC106, Single-Acting cylinder with 156 mm stroke
- Selected pump:**
- P392, Lightweight hand pump
- Set model number:**
- SCR106H
- Included:**
- HC7206 hose
 - GF10B gauge
 - GA2 adaptor

SC Series



Capacity:

5 - 95 ton

Stroke:

38 - 362 mm

Maximum Operating Pressure:

700 bar

2

Pump selection (See the Pump Section in this catalog for full product descriptions.)

Accessories included

3

Hand Pump P142	Hand Pump P392	Hand Pump P80	Foot Pump P392FP	XA-Series Air Pump XA11	XC-Series Cordless Pump XC1201ME ²⁾	Hose Model Number	Gauge Model Number	Gauge Adaptor Model Nr.
SCR55H	-	-	-	-	-	HC7206	GP10S	GA4
-	SCR102H	-	SCR102FP	SCR102XA	SCR102XCE	HC7206	GF10B	GA2
-	SCR106H	-	SCR106FP	SCR106XA	SCR106XCE	HC7206	GF10B	GA2
-	SCR1010H	-	SCR1010FP	SCR1010XA	SCR1010XCE	HC7206	GF10B	GA2
-	SCR154H	-	SCR154FP	SCR154XA	SCR154XCE	HC7206	GP-10S	GA2
-	SCR156H	-	SCR156FP	SCR156XA	SCR156XCE	HC7206	GP-10S	GA2
-	SCR252H	-	SCR252FP	SCR252XA	SCR252XCE	HC7206	GF20B	GA2
-	SCR254H	-	SCR254FP	SCR254XA	SCR254XCE	HC7206	GF20B	GA2
-	SCR256H	-	-	SCR256XA	SCR256XCE	HC7206	GF20B	GA2
-	-	SCR2514H	-	SCR2514XA ¹⁾	-	HC7206	GF20B	GA2
-	-	SCR506H	-	SCR506XA ¹⁾	-	HC7206	GF50B	GA2
-	SCL101H	-	SCL101FP	SCL101XA	-	HC7206	GF10B	GA2
-	SCL201H	-	SCL201FP	SCL201XA	-	HC7206	GF230B	GA2
-	SCL302H	-	SCL302FP	SCL302XA	SCL302XCE	HC7206	GF230B	GA2
-	SCL502H	-	SCL502FP	SCL502XA	SCL502XCE	HC7206	GF510B	GA2
-	-	SCL1002H	-	-	SCL1002XCE	HC7206	GF510B	GA2
SCH121H	-	-	-	-	-	HB7206	GF120B	GA4
-	SCH202H	-	SCH202FP	SCH202XA	SCH202XCE	HC7206	GF813B	GA3
-	SCH302H	-	SCH302FP	SCH302XA	SCH302XCE	HC7206	GF813B	GA3
-	-	SCH603H	-	SCH603XA ¹⁾	SCH603XCE	HC7206	GF813B	GA3
-	-	SCH1003H	-	-	-	HC7206	GP10S	GA2

¹⁾ With XA12 air pump.

²⁾ Cordless Pump includes 230V Charger. For 115V charger replace the "E" by the "B" in the model number.

▼ HF95X, HF95Y, THQ706T



HF, THQ Series

Contents Hydraulic Oil:

1, 5 and 20 litres

Hose Lengths:

2, 6 and 12 metres

Maximum Operating Pressure:

700 bar



HT, B-Series, 1500 bar Hoses and Fittings for Tensioning

Bolt tensioning equipment require different hoses, couplers and fittings than torque wrenches and pumps.

Page: **91**

Premium Hydraulic Oil

- Maximum pump volumetric efficiency; high viscosity index
- Maximum internal heat transfer; prevents pump cavitation
- Additives prevent rust, oxidation and sludge
- Maximum film protective lubricity.

Twin Torque Wrench Hose

- Thermo-plastic safety dual hoses for Enerpac 700 bar hydraulic torque wrenches and torque pumps
- For demanding applications, featuring a 4:1 safety factor
- Maximum working pressure of 700 bar
- Outside jacket is polyurethane, to provide maximum abrasion resistance
- Low volumetric expansion under pressure to enhance overall system efficiency
- Crimped-on vinyl strain relief for improved life and durability on all models.

▼ Use the THQ-Series hoses with Enerpac torque wrenches and pumps to ensure the integrity of your hydraulic system.



Hydraulic Oil

Contents *	Model Number *	Use only genuine Enerpac Hydraulic Oil. The use of any other fluid will render your Enerpac warranty null and void.
1 litre	HF95X	
5 litres	HF95Y	
20 litres	HF95T	

* Oil model numbers and contents may vary by region, contact Enerpac.

▼ OIL SPECIFICATION CHART

Viscosity Index	100 min
Viscosity (cSt @ 40 °C)	32
API Gravity	31-33
Density (cSt @ 15 °C)	875
Flash point	204 °C
Pour point	-32 °C
Colour	Blue
Working Temperature Range	0 - 60 °C
Ideal working temperature	40 °C

Internal Diameter (mm)	Hose Ends Assemblies and Couplers *		Hose Length (m)	Model Number	Weight (kg)
	Hose one	Hose two			
6,4	female half + male half	male half + female half	2,0	THQ702T	2,2
	female half + male half	male half + female half	6,0	THQ706T	4,5
	female half + male half	male half + female half	12,0	THQ712T	7,6

* 1/4" Spin-on Torque Wrench Couplers. **TR630** female half, **TH630** male half.

Hydraulic Wedgie and Spread Cylinders

▼ Shown clockwise from top: **WR15, WR5, A92**



A, WR Series

Capacity:

0,75 - 1,0 ton

Tip Clearance:

12,8 - 35 mm

Maximum Spread:

94 - 292 mm

Maximum Operating Pressure:

700 bar

- **WR5:** For use in very confined work areas
- **WR15:** For long stroke spreading applications
- **Single-acting, spring return**
- **A92:** Spreader attachment; threads on 10 ton RC-Series cylinders * (except RC101).

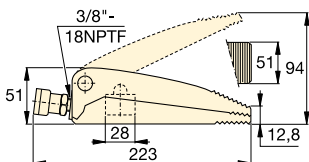

WR5

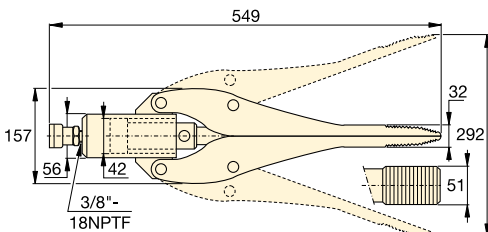

WR15

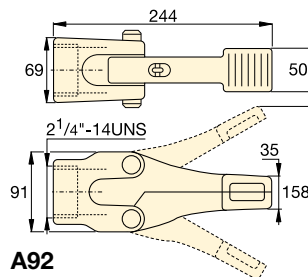

A92

Cylinder Capacity	Tip Clearance	Model Number	Maximum Spread	Cylinder Effective Area	Oil Capacity	
ton (kN)	(mm)		(mm)	(cm ²)	(cm ³)	(kg)
1,0 (8,9)	12,8	WR5	94	6,5	10	2,3
0,75 (6)	32,0	WR15	292	14,5	64	11,3
1,0 (8,9)	35,0	A92 *	158	—	—	3,6

* Maximum system pressure must be limited to half the rated pressure (350 bar).



Power Box, The Portable Toolbox

Tool box with **P392** hand pump, gauge adaptor assembly, hose and **WR5** spreader.

Page: 95



Best Match Hand Pump

To power your WR5 and WR15 the **P392** hand pump is an ideal choice. Use Enerpac H700-Series hose for hydraulic connection. www.enerpac.com

▼ A WR5 wedgie cylinder is used to loosen a bridge bearing.

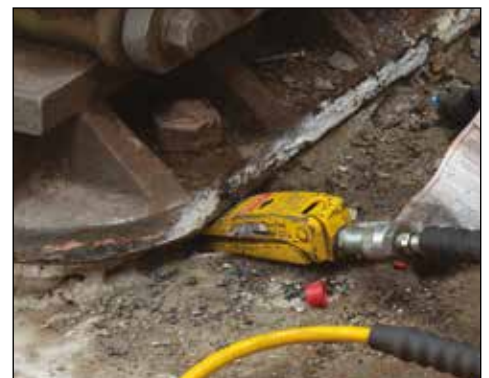

▼ From left to right: **ATM4, ATM9, ATM2** (ATM9 shown without pump and hose)



- Enerpac ATM-Series tools rectify twist and rotational misalignment quickly, safely and without the need for an external power source
- Appropriate for use on most ANSI, API, BS and DIN flanges
- Reduces set-up time: no need for chains, pulleys or rigs
- Safety strap helps provide secure operation
- Can be installed and used in any position
- Stays stable in position under full load
- Portable, lightweight design enables easy transport and use, even in remote locations
- Each ATM-model contains a tool and kit box.

▼ The compact ATM2 is actuated by simply hand turning the crank.



The faster, simpler and safer way to align flanges



Adjustable Reach

The highly adjustable reach of the wing and drop leg on ATM4 and ATM9 allow precise alignment.



Gauge and Adaptor

The ATM9 includes P142 hand pump and HC7206C 1,8 m long hose. Enerpac recommend the use of the pressure gauge **GP10S** and gauge adaptor **GA4** for easy mounting of the gauge onto your system or use **GA45GC** Gauge Adaptor Assembly.



TFA-Series Wind Turbine Tower Flange Alignment Tools

The TFA Wind Turbine Tower Flange Alignment Tools have been developed to aid the alignment of large flanges on the inside of wind turbine towers during their assembly or installation.

Page: 124

▼ The ATM9 is shown here with optional pressure gauge and gauge adaptor.





Applications

Enerpac ATM-Series Tools help correct flange misalignment, and allow bolts to be placed into joints. This alignment takes place during pipework construction, or maintenance.

These tools provide pipe installers and maintenance personnel with some of the simplest, safest and most productive solutions available for flange alignment in the market today.

- ① Extendable wing provides usage on wide variety of flanges.
- ② Portable, light weight design enables easy transport and use.
- ③ Hand-adjustable base for easy positioning by a single operator.
- ④ Safety strap helps provide secure operation from a horizontal or vertical position.

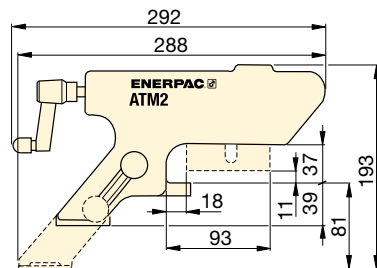
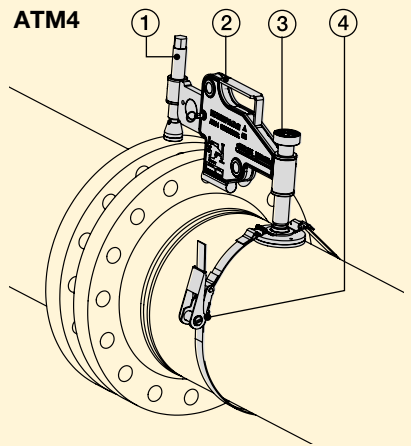

ATM2

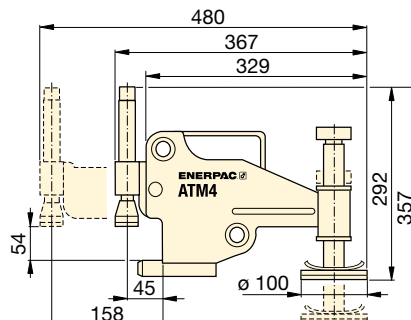

ATM4

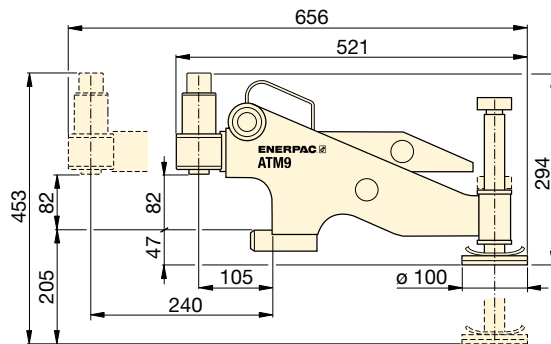

ATM9

Maximum Lifting Force		Model Number	Minimum Bolt Size		Flange Wall Thickness		Weight (kg)
(ton)	(kN)		(mm)	(inch)	(mm)	(inch)	
1	10	ATM2	16	.63	14 - 82	.55 - 3.29	1,6
4	40	ATM4	24	.95	30 - 133	1.18 - 5.23	8,6
9	90	ATM9 *	35,5	1.40	93 - 228	3.66 - 9.00	14,5

* ATM9 includes an Enerpac hand pump and hydraulic hose (gauge and adaptor sold separately). ATM9 weight includes tool only.

ATM Series



Minimum Bolt Size:

16 - 35,5 mm

Flange Wall Thickness:

14 - 228 mm

Maximum Lifting Force:

1 - 9 ton (10 - 90 kN)



Cylinder-Pump Sets

Hydraulic cylinders, jacks and lifting wedges can also be used to assist in pipe line positioning and aligning.

Page: 98



Pipe Flange Face Tool

The portable, hand powered tool FF120 makes even the hardest to reach pipe flanges resurfaceable in a safe and convenient way.

Page: 110

▼ The ATM-Series – the faster, simpler and safer way to align flanges.



▼ FSC14, FSM8 and FSH14 with safety blocks SB1



- **Unique interlocking wedge design** no first step bending and risk of slipping out of joint
- **Requires very small access gap of only 6 mm**
- **Few moving parts mean durability and low maintenance**
- **Safety block SB1 included with FSC14, FSH14 and FSM8**
- **Ratchet spanner SW22 included with FSM8 mechanical spreader**
- **Single-acting cylinder included with FSH14 hydraulic spreader.**

▼ Two FSH14 spreaders used simultaneously with Enerpac handpump, hoses and AM21 control manifold.



Practical, portable and lightweight



FSC14 with integrated hand pump

Powered by a builtin hydraulic hand pump, the FSC14 is a readytouse tool – no making or breaking hydraulic connections. This compact tool delivers 14 US tons of force and requires a clearance gap as small as 6 mm.



Stepped Blocks FSB1

Use stepped blocks to increase wedge opening up to 80 mm. Fits both FSC, FSH and FSM-models.



AM-Series Control Manifolds

For simultaneously and even spreading of flange joints, 180° apart with FSH14.



Flange Maintenance Tools

Secure-Grip and Zero-Gap flange spreading tools for application on flanges with a zero or small gap.

Flange Spreading Wedges



Flange Spreading Wedges

The flange spreading tools have been developed to aid and simplify the maintenance of flange joints. No longer will those tasked with separating flanges have to rely on using ropes and pulleys, podgers, tiffors, come-alongs or hammers – there is a safe, quick and effective alternative, the Enerpac range of spreaders.

These spreaders use mechanical and hydraulic principles for separating flanges and can spread small, medium or large flange joints. Tool selection is made on the basis of the access gap between the flange faces, the flange size and the required scope of work.

FSC, FSH, FSM, Series



Tip Clearance / Maximum Spread ¹⁾:

6 mm / 80 mm

Maximum Spread Force:

8 - 14 US tons

Maximum Operating Pressure:

700 bar (FSH14)

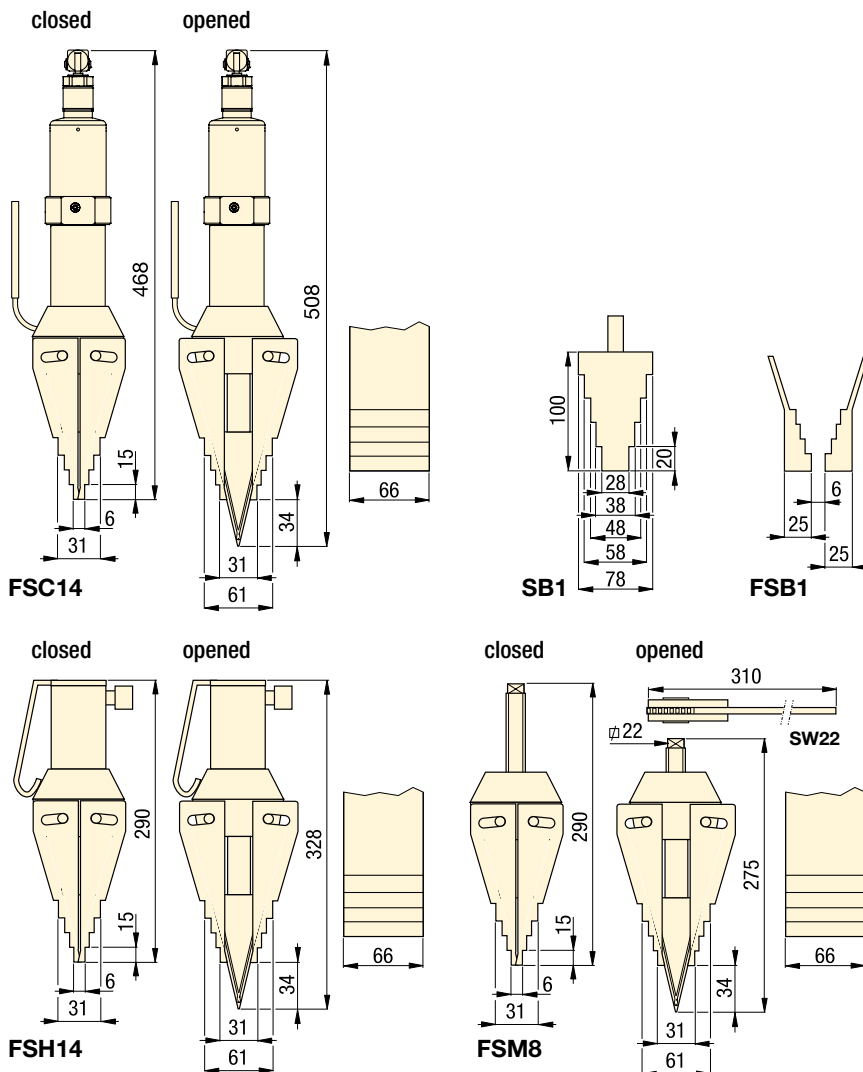

Safety Lanyard FSC1

Recommended safety accessory to compliment bolting applications. Includes steel cable with carabiners.

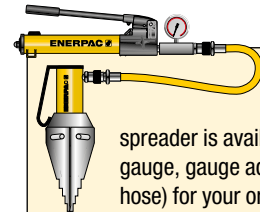

Tool-Pump Sets

The hydraulic flange spreader is available as set (pump, tool, gauge, gauge adaptor, couplers and hose) for your ordering convenience.

Spreader Model Nr.	Handpump Model Nr.	Set Model Number
FSH14	P392	STF14H

▼ Flange maintenance and joint separation with FSH14 Hydraulic Wedge Spreader.



Maximum Spreading Force US tons (kN)	Model Number	Tip Clearance (mm)	Maximum Spread ¹⁾ (mm)	Spreader Type	Oil Capacity (cm ³)	Weight (kg)
14 (118)	FSC14	6	80	Integral hydraulics	–	9,0
14 (125)	FSH14 *	6	80	External hydraulics	78	7,1
8 (72)	FSM8	6	80	Mechanical	–	6,5

¹⁾ Using stepped blocks FSB1.

* Available as pump-tool set, see note on this page.

▼ Shown from left to right: NC3241, NC1019, NC1924



- Compact and ergonomic design, easy to use
- Unique angled head design
- Two blade design (NC-D models) for time saving operation – nuts are split from two sides in one action
- Single-acting, spring return cylinder
- Heavy duty chisels can be reground
- Nut splitters include spare chisel, spare set screw and wrench used to secure the chisel.
- CR400 female half coupler is standard.

▼ Enerpac hydraulic nut splitters – the safest and easiest way to remove corroded and frozen nuts.



The safest and easiest way to remove corroded and frozen nuts

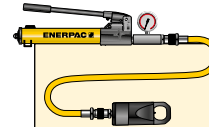

Tool-Pump Sets

Hydraulic Nut Splitters are available as sets (pump, tool, gauge, gauge adaptor, couplers and hose) for your ordering convenience.

Nut Splitter Model Nr.	Hand Pump Model Nr.	Nut Splitter Set Model Number
NC1924	P392	STN1924H
NC2432	P392	STN2432H
NC3241	P392	STN3241H



High Pressure Hoses

Enerpac offers a complete line of high quality hydraulic hoses. To ensure the integrity of your system, specify only genuine Enerpac hydraulic hoses.



GA45GC Gauge Adaptor Assembly

Protect yourself from system overloading by simply ordering one part number for a pre-assembled gauge, adaptor block and coupler.

Single-Acting Hydraulic Nut Splitters



Frozen or Corroded Nuts

Often nuts are difficult to remove, while loosening using tightening tools is possible, it generally requires larger equipment and is time consuming. The use of cutting torches or hammers and chisels can cause damage to the joint components, requires significantly longer setup and operational time, and can present a potential safety risk.

Hydraulic Nut Splitters

Nut splitting with the Enerpac Hydraulic Nut Splitters is the safest method. It takes less time and avoids costly damage to joint components. The head design fitted with heavy-duty chisels permits the splitting of nuts on a wide variety of applications. With the two blades models nuts are split from two side in one action.

NC STN Series



Bolt Range:
M6 - M48

Hexagon Nut Range:
10 - 75 mm

Capacity:
49 - 882 kN

Maximum Operating Pressure:
700 bar

For Nut Splitter Model Nr.	Replacement Chisel Model Numbers	
	Moving	Static
NC1019	NCB1019	-
NC1924	NCB1924	-
NC2432	NCB2432	-
NC3241	NCB3241	-
NC4150	NCB4150	-
NC5060	NCB5060	-
NC6075	NCB6075	-
NC1924D	NCB1924	NCB1924D
NC2432D	NCB2432	NCB2432D
NC3241D	NCB3241	NCB3241D



IMPORTANT!

These nut splitters are only designed for **grade 8 metal nuts** which match sizes shown in the specifications chart. These are not suited for square, star, round or stainless steel nuts. Maximum allowable hardness of nuts to be split is HRc-44.

For materials and sizes not specified, contact Enerpac Technical Services.

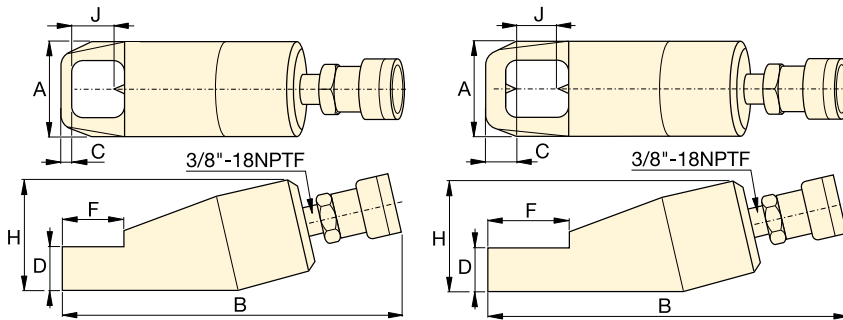

Single Blade Models (NC)

Double Blade Models (NC-D)

	Bolt Range (mm)	Hexagon Nut Range (mm)	Maximum Cutting Force ton (kN)	Oil Capacity (cm ³)	Model Number	Dimensions (mm)						Weight (kg)	
						A	B	C	D	F	H		J
	M6 - M12	10 - 19	5 (49)	15	NC1019	40	170	7	19	28	48	21	1,2
	M12 - M16	19 - 24	10 (98)	20	NC1924 *	54	191	10	26	40	62	25	2,0
	M16 - M22	24 - 32	15 (147)	60	NC2432 *	64	222	13	29	51	72	33	3,0
	M22 - M27	32 - 41	20 (196)	80	NC3241 *	75	244	17	36	66	88	43	4,4
	M27 - M33	41 - 50	35 (343)	155	NC4150	94	288	21	45	74	105	54	8,2
	M33 - M39	50 - 60	50 (490)	240	NC5060	106	318	23	54	90	128	60	11,8
	M39 - M48	60 - 75	90 (882)	492	NC6075	156	393	26	72	110	181	80	34,1
	M12 - M16	19 - 24	10 (98)	20	NC1924D	54	168	22	25	50	66	26	3,8
	M16 - M22	24 - 32	15 (147)	60	NC2432D	64	275	25	31	65	78	33	5,4
	M22 - M27	32 - 41	20 (196)	80	NC3241D	77	305	31	37	80	90	43	7,2

* Available as Tool-Pump Set, see note on page 106.

▼ Shown: NSH31 with NSPH3, NSH41 with NSPH4



- Designed to fit standard BS/ANSI flanges
- Blade positioning scale to eliminate bolt damage
- Adjustable cutting depth
- Ergonomically designed and positioned handle
- Interchangeable power heads with cutting blade
- Single-acting spring return power head (NSPH)
- Double-acting power head (NSPH-D) for subsea operation
- Nut splitters include spare chisel, spare set screw and wrench used to secure the chisel
- CR400 female half coupler standard on NSPH
- CR400 + CH604 couplers standard on NSPH-D.

ATEX certified

- All NSH-cutting heads are CE - ATEX certified.

Versatile, reliable and trouble free operation



Blade Positioning Scale

The power head can be adjusted to preset the blade cutting distance in order to prevent damage to the bolt thread as the nut is cut.

The blade positioning scale can be used with the following bolt and nut forms:

- Unified bolt threads (UN) with heavy series hexagon nuts;
- Metric bolt threads (M) with standard series hexagon nuts.



Steel Hand Pumps

The **P80** and **P84** two speed hand pumps are ideal to operate nut splitters. The **P84** can be used to power the double-acting tools.



High Pressure Hoses

Enerpac offers a complete line of high quality hydraulic hoses. To ensure the integrity of your system, specify only genuine Enerpac hydraulic hoses.

Single- and Double-Acting Hydraulic Nut Splitters



Hydraulic Nut Splitters

These Hydraulic Nut Splitters are the ideal tools for removing seized and corroded nuts, eradicating the need for unsafe grinding or flame cutting.

They are designed with a single acting spring return cylinder and boast a 360 degree rotation, lockable handle improving operator safety.

The heavy duty blades can also be easily removed to enable replacement blades to be fitted.

Operator Safety

To improve operator safety an ergonomic, adjustable handle is available which can be easily fitted to the Nut Splitter.

This lightweight, durable accessory can prevent injuries such as trapped fingers by eliminating the need to hold the tool itself.

ATEX Certified: Ex II 2 G c T6

These Nut Splitters are tested and certified to conform to the 94/9/EC "ATEX Directive". The explosion protection is for Equipment Group II, Equipment Category 2 (Hazardous Zone Area 1) in Gas and/or Dust atmospheres.

NSH Series



Bolt Range:

M45 - M90

Hexagon Nut Range:

70 - 130 mm

Maximum Operating Pressure:

700 bar

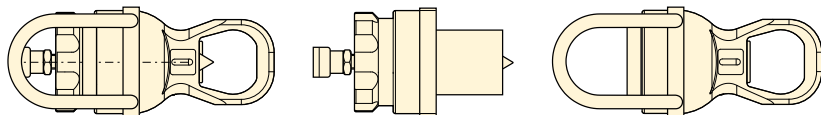

Complete Nut Splitter = Power Head (NSPH) + Cutting Head (NSH)

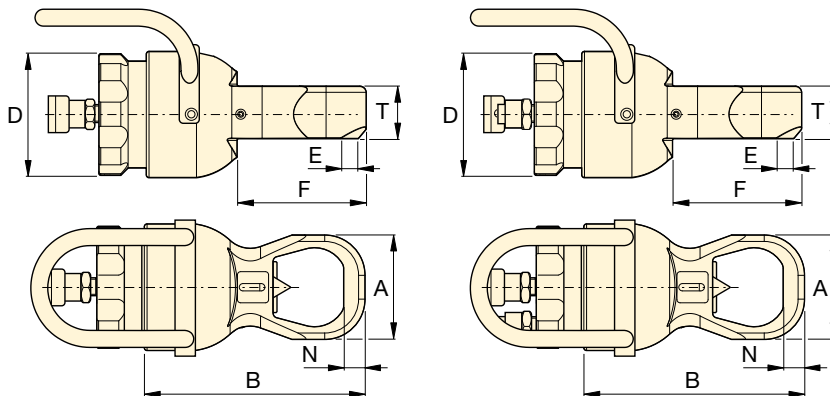

NSPH + NSH

NSPH-D + NSH



Joint Separation Tools

Flange Spreading Wedges (FSC, FSH, FSM-Series) provide quick and easy joint separation using hydraulic or mechanical force.

Page: 104

For Power Head Model Nr.		Cutting Tip Service Kit Model Nr.
NSPH3	NSPH3D	NSPH3CTK
NSPH4	NSPH4D	NSPH4CTK

▼ NUT SPLITTER SPECIFICATIONS

Bolt Range (mm)	Hexagon Nut Range (mm)	Maximum Cutting Force ton (kN)	Oil Capacity (cm ³)	Model Numbers Nut Splitter Components				Dimensions (mm)							Cutting + Power Head (kg)	
				Cutting Head	Power Heads	Single-acting	Double-acting	A	B	D	E	F	N	T		
M45 - M52	70 - 80	105 (1025)	550	NSH31	20	NSPH3	NSPH3D	22	132	308	190	7	189	28	81	42
M45 - M56	70 - 85	105 (1025)	550	NSH32	21	NSPH3	NSPH3D	22	145	323	190	15	200	30	81	43
M45 - M64	70 - 95	105 (1025)	550	NSH33	22	NSPH3	NSPH3D	22	160	331	190	11	200	32	81	44
M45 - M70	70 - 100	105 (1025)	550	NSH34	22	NSPH3	NSPH3D	22	174	342	190	11	204	35	81	44
M76 - M80	110 - 115	178 (1733)	1100	NSH41	32	NSPH4	NSPH4D	38	189	365	235	4,5	230	36	111	70
M76 - M90	110 - 130	178 (1733)	1100	NSH42	44	NSPH4	NSPH4D	38	219	393	235	3	246	36	111	82

Ordering Notes: Maximum allowable hardness to split is ASTM A194 Gr 2H. Not to be used on square nuts or stainless steel.

▼ FF120



- Makes refacing easy – hand operated machine tool can be set up anywhere without the need for air, electric or hydraulic power
- Lightweight and portable (15 kg in storage box)
- Adjustable cutting head for reface of flat flange surfaces of pipes with flange outside diameter facing range 25,4 - 304,8 mm [1 - 12 inch]
- Interchangeable collets for ID mounting range 25,4 - 152,4 mm [1-6 inch] allow the user to work on many different flanges with minimal time between set-ups
- Interchangeable lead screws suitable for refacing damaged raised-face (RF) or flat-face (FF) joint flanges
- Tool body with expanding collets centers itself providing real concentric operation.

▼ The Enerpac FF120 used to face a pipe flange.



Safe, efficient and accurate refacing of flat pipe flange surfaces



Complete in Wheeled Carrying Case

The FF120 comes as portable set (15 kg). Can be transported, easy set-up and operated by a single

technician. Set includes:

FFL-kit with locators, O-Rings and extensions;
FSS-kit with feed screw and nut ½”-20 UN for surface roughness Ra 1,6 - 2,4 μ.

FSF-kit with feed screw and nut ½”-11 UNF for surface roughness Ra 3,2 - 6,3 μ.



Joint Separation Tools

FSC, FSH, FSM-Series parallel wedge spreaders provide quick and easy joint separation using hydraulic or mechanical force.

Page: 104



Flange Alignment Tools

The ATM-Series provide safe and high-precision flange alignment tools that fit most commonly used ANSI, API, BS and DIN flanges.

Page: 102



Controlled Tightening and Loosening

Use Enerpac Bolting Tools to seal the joint to the precise torque or tension required: torque

multipliers, torque wrenches and hydraulic bolt tensioners.

Page: 1

QuickFace – Mechanical Pipe Flange Face Tool



Mechanical Flange Face Tool

Portable, hand powered tool makes even the hardest to reach pipe flanges resurfaceable in a safe and convenient way.

Makes refacing easy

A simple and cost effective solution – the FF120 turns a two man operation with heavy equipment, compressors and portable generators into a one man job.

The FF120 has interchangeable lead screws that make it suitable for resurfacing damaged flat-faced or raised-face joint flanges to the high safety standards required. FF120 is not suitable for lens-ring joint flanges or ring type joint (RTJ) flanges.

After selecting the correct lead screw for the operation, the tool body is inserted in the pipe end and centres itself with adjustable locators to provide real concentric operation.

The tool arm is then rotated by hand using a worm-gear mechanism to provide a perfect spiral “gramophone” finish. The tool can be adjusted with a calibrated slide to define cut depth and the correct finish.

Surface finish & accuracy

A serrated finish with 30-55 grooves per inch and a resultant roughness of between Ra 3,2-12,5 µ (125-500 micro inches). The FF-120 has same precision and quality of finish as a lathe.

Cost effective solution

Small and portable enough to be a permanent addition to your equipment range, Enerpac’s FF120 is the perfect solution to all of your small diameter facing problems.

See page 128 for more **MIRAGE On-site Machining Products**.

FF Series



Pipe Flange Cutting Diameter Range:

Ø 25 - 305 mm / 1 - 12"

Internal Pipe Mounting Range:

Ø 25 - 152 mm / 1 - 6"

Cutting Resultant Roughness:

Ra 3,2 - 12,5 µ



- 1 Hand-operated cold work tool – no need for external power and hot work permits.
- 2 Calibrated cross slide for accurate cutting control.
- 3 Adjustable cutting head for reface of flat flange surfaces of pipes with flange OD facing range Ø 25,4-304,8 mm [1-12 inch].
- 4 Interchangeable lead screws enable selection of surface finish between Ra 3,2-12,5 µ.
- 5 Utilizes standard 3/8 inch or 10 mm tool steel.
- 6 Range of interchangeable collets allow the tool to accommodate Ø 25,4 - 152,4 mm (1 - 6 inch) pipe ID.
- 7 Tool body with expanding collets centers in the bore ensuring concentric and accurate set-up.

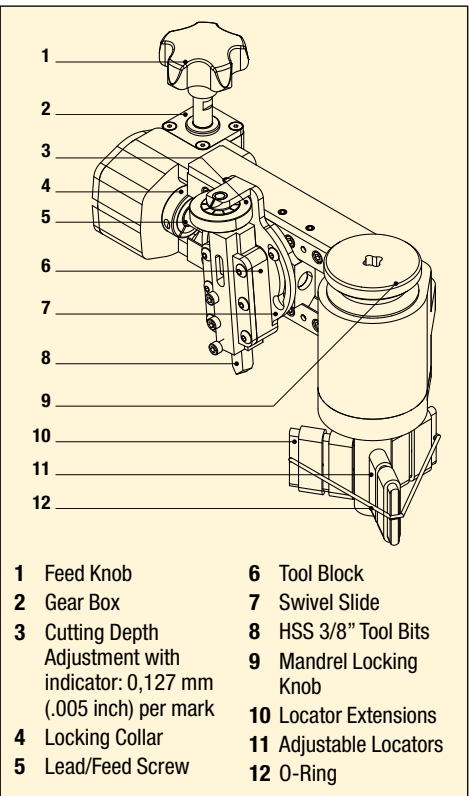

- | | |
|--|------------------------|
| 1 Feed Knob | 6 Tool Block |
| 2 Gear Box | 7 Swivel Slide |
| 3 Cutting Depth Adjustment with indicator: 0,127 mm (.005 inch) per mark | 8 HSS 3/8" Tool Bits |
| 4 Locking Collar | 9 Mandrel Locking Knob |
| 5 Lead/Feed Screw | 10 Locator Extensions |
| | 11 Adjustable Locators |
| | 12 O-Ring |

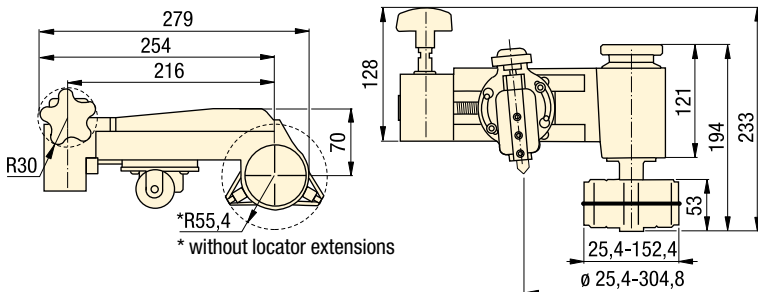

SELECTION CHART

Pipe Flange Cutting Diameter Range		Internal Pipe Mounting Diameter Range		Cutting Resultant Roughness	Model Number	Model Weight (kg)
(mm)	(inch)	(mm)	(inch)			
25,4 - 304,8	1,0 - 12,0	25,4 - 152,4	1,0 - 6,0	3,2 - 12,5	FF120	6,8

▼ The Enerpac FF120 QuickFace has same precision and quality of finish as a lathe.



The Equalizer™ range of patented flange spreading tools have been developed to aid and simplify the maintenance of flange joints. No longer will those tasked with separating flanges have to rely on using ropes and pulleys, podgers, tirsors, come-alongs or hammers – there is a safe, quick and effective alternative, the

Equalizer™ range of spreaders. These spreaders use mechanical and hydraulic principles for separating flanges and can spread small, medium or large flange joints. Tool selection is made on the basis of the access gap between the flange faces, the flange size and the required scope of work.

SWi Flange Spreading Wedges:

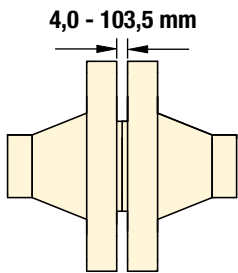

An innovative flange spreading wedge for use on small, medium or large flange joints with a minimum access gap of 4 mm. The SWi range includes ATEX approved options.

MG Flange Spreading Tool:

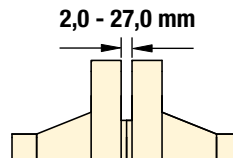

A mechanical tool for small diameter, low pressure flanges with a minimum access gap of 2 mm.

For use on smaller, lower pressure flange joints, this portable and flexible tool can be assembled in two alternative configurations that gives it twice the application range from one tool. The tool is locked onto the flange joint by the spreading bar preventing the risk of it falling from the flange joint.

The SWi range has set the new standard for spreading flange joints powerfully, efficiently, effectively and safely. The tools offer the following features and benefits:

- Wider spreading - using the Standard Stepped Block accessories means the SWi range offers up to 30% more flange spreading distance than a traditional SW tool.
- Unrivalled power - the tools now offer up to 240 kN of spreading force when used in pairs, which provides additional confidence when spreading.
- Narrower jaws - the SWi5T tools are only 50 mm wide to help them fit more easily between flange bolts.
- Fully rotational handle – the handle swivels 360-degrees around the wedge head, so that the SWi tools can be used comfortably in all orientations.
- Easier maintenance – end-users will appreciate the ease with which the tools can be maintained. The supplied hex-key and a two step-process is all that's required to disassemble and reassemble the tools.
- No pinch points – the SWi range of tools has been engineered to overcome finger pinch-points.

SG Flange Spreading Tools:

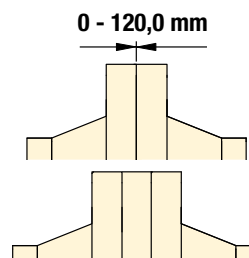

A unique flange spreader, ideal for situations where there is no access gap, or where there is a spacer, a wafer or butterfly valve positioned between the flanges.

Equalizer's unique Secure-Grip tools spread by locking into the flange bolt holes and pulling the mating flanges away from each other, the Secure Grip flange spreaders are locked on to the flanges when under load making them arguably the world's safest flange spreading tools.

VC Valve Change-Out Tools:

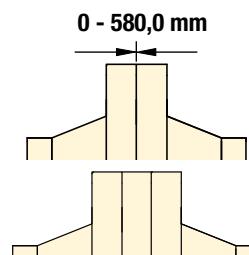

Using the same technology as the SG flange spreaders the VC range has been developed for valve removal applications.

The Equalizer™ VC Range of Valve Change-Out tools has been developed to assist in the removal of valves, spades/spacers or gaskets from large flange joints. The span of the tool is longer than a standard Secure-Grip Flange Spreader and is adjustable to enable the tool to operate in a range of applications.

Flange Spreading Tools

▼ MG7TM



- Reversible leg design giving greater range of applications
- Unique double-angled wedge produces a greater spreading force without reducing spreading distance
- Robust lightweight tool
- Spreading force of 68,0 kN.

OPERATING BENEFITS

- Locks on to flange joint
- Safe, quick and easy operation
- Saves time and cost.

MG Series

FLANGE SPREADING TOOL

Spreading Force:

68,0 kN

Spreading Distance:

2,0 - 27,0 mm



Range of Application

For a detailed range of application please request the MG7TM Operator Instruction Sheet.



Caution

A minimum of two Flange Spreading Tools must be used when opening flange joints. This will enable the operator to maintain an equal spreading distance across the flange faces.

MG7TMSTD Standard Kit



- 1 x MG7TM Tool
- 2 x Spreading Bar
- 1 x Moulded Plastic Carry Case

Tool retracted and advanced using large (Ø 20mm) spreading bar

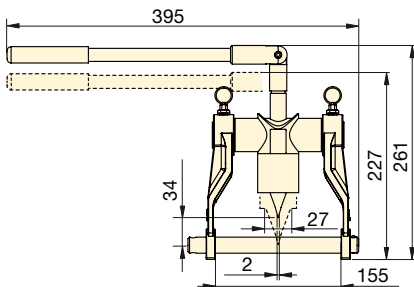

Tool retracted and advanced using small (Ø 16mm) spreading bar

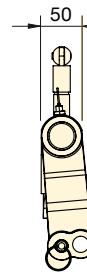
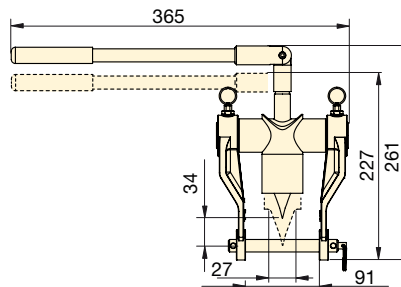

Flange Dimensions

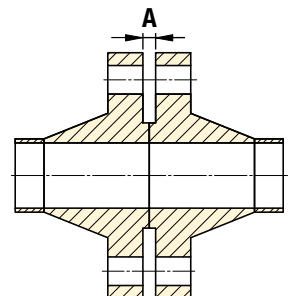

Model Number Tool Kit	Type	Maximum Spreading Force Per Tool (kN)	Spreading Distance Maximum (mm)	Flange Dimensions Minimum Access Gap A (mm)	Wedge Width (mm)	Tool Weight (kg)	Kit Weight (kg)	Case Dimensions (mm)	Tool Number
MG7TMSTD	Mechanical	68,0	27,0	2,0	45,0	5,0	5,5	360 x 300 x 90	MG7TM

▼ SWi5TI-S



SWi Series

FLANGE SPREADING WEDGES

Spreading Force:

77,0 - 240,0 kN

Spreading Distance:

4,0 - 103,5 mm

Maximum Operating Pressure:

700 bar *

* Only relevant for hydraulic tools

- Practical, portable and lightweight
- Revolving handle to aid horizontal or vertical spreading
- Removable handle for improved access
- No finger pinch-point
- Increased step-depth on upper steps
- Safety lanyard – 1,0 m length
- Forged key components for strength and reliability
- Rapid disassembly and assembly
- Narrow jaw teeth – improved tool wear.



Caution

A minimum of two Flange Spreading Tools must be used when opening flange joints. This will enable the operator to maintain an equal spreading distance across the flange faces.

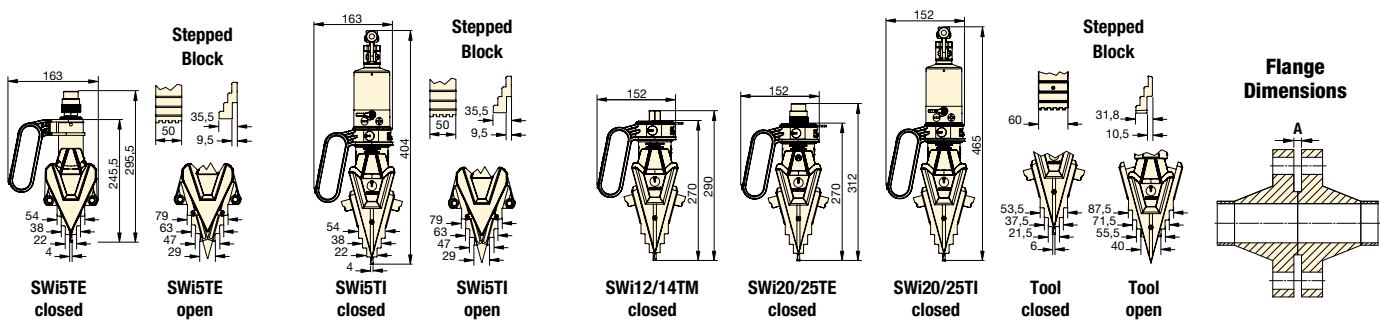

Model Number Tool Kit	Type	Maximum Spreading Force Per Tool (kN)	Spreading Distance Maximum * (mm)	Flange Dimensions Minimum Access Gap A (mm)	Jaw Width (mm)	Tool Weight (kg)	Kit Weight (kg)	Case Dimensions (mm)	Tool Number
SWi5TE-S	External Hydraulic	77,0	101,0	4,0	50,0	5,2	8,7	580 x 340 x 180	SWi5TE
SWi5TE-T	External Hydraulic	77,0	101,0	4,0	50,0	5,2	14,4	580 x 340 x 180	SWi5TE
SWi5TI-S	Integral Hydraulic	77,0	101,0	4,0	50,0	7,0	10,5	580 x 330 x 180	SWi5TI
SWi1214TMSTDSPB	Mechanical	140,0	103,5	6,0	60,0	6,2	13,0	580 x 330 x 165	SWi12/14TM
SWi2025TEMINSPB	External Hydraulic	240,0	103,5	6,0	60,0	6,4	11,6	580 x 330 x 165	SWi20/25TE
SWi2025TESTDSPB	External Hydraulic	240,0	103,5	6,0	60,0	6,4	20,7	920 x 500 x 205	SWi20/25TE
SWi2025TEMAXSPB	External Hydraulic	240,0	103,5	6,0	60,0	6,4	33,0	920 x 500 x 205	SWi20/25TE
SWi2025TISTDSPB	Integral Hydraulic	240,0	103,5	6,0	60,0	8,5	13,8	580 x 330 x 165	SWi20/25TI

* Using stepped blocks.

Flange Spreading Tools

SWi5TE - Hydraulic Flange Spreading Wedge

SWi5TE-S - SWi5TE S Kit



- 1 x SWi5TE Flange Spreading Tool
- 1 x Standard Safety Block
- 1 x Lanyard
- 1 x Moulded Plastic Carry Case with Protective Foam Inserts

SWi5TE-T - SWi5TE T Kit



- 2 x SWi5TE Flange Spreading Tools
- 2 x Standard Safety Blocks
- 2 x Lanyards
- 1 x Moulded Plastic Carry Case with Protective Foam Inserts

1640016-01 - SWi5TE Stepped Block Kit



- 1 x Pair of SWi5TE Stepped Blocks
- 2 x M6 CSK Hex Screw
- 2 x Retaining Washer
- 1 x SWi5TE Large Safety Block
- 2 x Hex Key

SWi12/14TM - Mechanical Flange Spreading Wedge

SWi1214TMSTDSPB - SWi12/14TM STD Kit



- 1 x SWi12/14TM Flange Spreading Tool
- 1 x Torque Wrench with 22 mm Socket
- 1 x Set of Safety Blocks
- 1 x Pair of Stepped Blocks
- 1 x Lanyard
- 1 x Hex Key
- 1 x Moulded Plastic Carry Case

SWi20/25TE - Hydraulic Flange Spreading Wedge

SWi2025TEMINSPB - SWi20/25TE MIN Kit



- 1 x SWi20/25TE Flange Spreading Tool
- 1 x Set Safety Blocks
- 1 x Pair of Stepped Blocks
- 1 x Lanyard
- 1 x Hex Key
- 1 x Moulded Plastic Carry Case

SWi2025TESTDSPB - SWi20/25TE STD Kit



- 1 x SWi20/25TE Flange Spreading Tool
- 1 x 700 bar Hydraulic Hose, 2 m with 90° Elbow
- 1 x 700 bar HP350S Single-Port Sealed Hand Pump with Gauge
- 1 x Set Safety Blocks
- 1 x Pair of Stepped Blocks
- 1 x Lanyard
- 1 x Hex Key
- 1 x Moulded Plastic Carry Case

SWi2025TEMAXSPB - SWi20/25TE MAX Kit



- 2 x SWi20/25TE Flange Spreading Tools
- 2 x 700 bar Hydraulic Hoses, 2 m with 90° Elbow
- 1 x 700 bar HP550D Twin-Port Sealed Hand Pump with Gauge
- 2 x Set Safety Blocks
- 2 x Pair of Stepped Blocks
- 2 x Lanyards
- 2 x Hex Keys
- 1 x Moulded Plastic Carry Case

SWi5TI - Integral Hydraulic Flange Spreading Wedge

SWi5TI-S - SWi5TI S Kit



- 1 x SWi5TI Flange Spreading Tool
- 1 x Standard Safety Block
- 1 x Lanyard
- 1 x Moulded Plastic Carry Case with Protective Foam Inserts

1640016-01 - SWi5TE Stepped Block Kit



- 1 x Pair of SWi5TE Stepped Blocks
- 2 x M6 CSK Hex Screw
- 2 x Retaining Washer
- 1 x SWi5TE Large Safety Block
- 2 x Hex Key

SWi20/25TI - Integral Hydraulic Flange Spreading Wedge

SWi2025TISTDSPB - SWi20/25TI STD Kit



- 1 x SWi20/25TI Flange Spreading Tool
- 1 x Set of Safety Blocks
- 1 x Pair of Stepped Blocks
- 1 x Lanyard
- 1 x Hex Key
- 1 x Carry-Strap
- 1 x Moulded Plastic Carry Case

▼ SWi20/25TEEX



SWi Series



ATEX CERTIFIED FLANGE SPREADING WEDGES

Spreading Force:

140,0 - 240 kN

Spreading Distance:

6,0 - 103,5 mm

Maximum Operating Pressure:

700 bar *

* Only relevant for hydraulic tools

- ATEX certified
- Practical, portable and lightweight
- Revolving handle to aid horizontal or vertical spreading
- Removable handle for improved access
- No finger pinch-point
- Increased step-depth on upper steps
- Safety lanyard – 1,0 m length
- Forged key components for strength and reliability
- Rapid disassembly and assembly
- Narrow jaw teeth – improved tool wear.



Caution

A minimum of two Flange Spreading Tools must be used when opening flange joints. This will enable the operator to maintain an equal spreading distance across the flange faces.

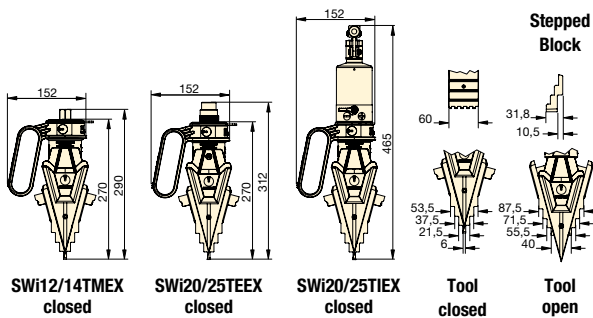

Flange Dimensions

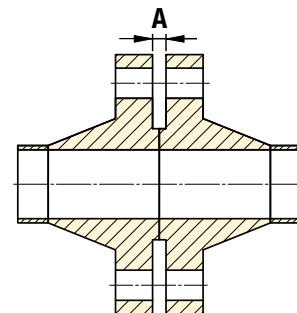

Model Number Tool Kit	Type	Maximum Spreading Force Per Tool (kN)	Spreading Distance Maximum * (mm)	Flange Dimensions Minimum Access Gap A (mm)	Jaw Width (mm)	Tool Weight (kg)	Kit Weight (kg)	Case Dimensions (mm)	Tool Number
SWi1214TMSTDEX	Mechanical	140,0	103,5	6,0	60,0	6,2	17,0	580 x 400 x 180	SWi12/14TMEX
SWi2025TEMINEX	External Hydraulic	240,0	103,5	6,0	60,0	6,4	15,0	580 x 400 x 180	SWi20/25TEEX
SWi2025TESTDEX	External Hydraulic	240,0	103,5	6,0	60,0	6,4	27,5	680 x 560 x 180	SWi20/25TEEX
SWi2025TEMAXEX	External Hydraulic	240,0	103,5	6,0	60,0	6,4	38,8	930 x 600 x 180	SWi20/25TEEX
SWi2025TISTDEX	Integral Hydraulic	240,0	103,5	6,0	60,0	8,5	17,5	580 x 400 x 180	SWi20/25TIEX

* Using stepped blocks.

Flange Spreading Tools

SWi12/14TMEX -
ATEX Certified Mechanical
Flange Spreading Wedge



II 2G Ex h IIB T5 Gb
II 2D Ex h IIIC T85°C Db

SWi1214TMSTDEX - SWi12/14TMEX STD Kit



1 x SWi12/14TMEX Flange Spreading Tool
1 x ATEX Torque Wrench with 22 mm Socket
1 x Set of Safety Blocks
1 x Pair of Stepped Blocks
1 x Lanyard
1 x Hex Key
1 x Aluminium Carry Case with Protective Foam Inserts

SWi20/25TEEX -
ATEX Certified Hydraulic
Flange Spreading Wedge



II 2G Ex h IIB T5 Gb
II 2D Ex h IIIC T100°C Db

SWi2025TEMINEX - SWi20/25TEEX MIN Kit



1 x SWi20/25TEEX Flange Spreading Tool
1 x Set Safety Blocks
1 x Pair of Stepped Blocks
1 x Lanyard
1 x Hex Key
1 x Aluminium Carry Case with Protective Foam Inserts

SWi20/25TIEX -
ATEX Certified Integral Hydraulic
Flange Spreading Wedge



II 2G Ex h IIB T5 Gb
II 2D Ex h IIIC T100°C Db

SWi2025TISTDEX - SWi20/25TIEX STD Kit



1 x SWi20/25TIEX Flange Spreading Tool
1 x Set of Safety Blocks
1 x Pair of Stepped Blocks
1 x Lanyard
1 x Hex Key
1 x Carry-Strap
1 x Aluminium Carry Case with Protective Foam Inserts

SWi2025TESTDEX - SWi20/25TEEX STD Kit



1 x SWi20/25TEEX Flange Spreading Tool
1 x 700 bar ATEX Hydraulic Hose, 2 m with 90° Elbow
1 x 700 bar HP350S ATEX Single-Port Sealed Hand Pump with Gauge
1 x Set Safety Blocks
1 x Pair of Stepped Blocks
1 x Lanyard
1 x Hex Key
1 x Aluminium Carry Case with Protective Foam Inserts

SWi2025TEMAXEX - SWi20/25TEEX MAX Kit



2 x SWi20/25TEEX Flange Spreading Tools
2 x 700 bar ATEX Hydraulic Hose, 2 m with 90° Elbow
1 x 700 bar HP550D ATEX Twin-Port Sealed Hand Pump with Gauge
2 x Set Safety Blocks
2 x Pair of Stepped Blocks
2 x Lanyards
2 x Hex Keys
1 x Aluminium Carry Case with Protective Foam Inserts



These tools have been designed for use in potentially explosive atmospheres which is:

- Group II (Non-mining equipment)
- Equipment **category 2** where explosive atmosphere is likely to occur in normal operation
- Can be applied in **zones 1 and 2** of gaseous explosive atmospheres and in **zones 21 and 22** of dust explosive atmosphere
- **Gas G** or **Dust D** with type of protection **Ex h** for non-electrical equipment
- Suitable for use with **Group IIB** of a gases and vapours (Ethylene group) and **Group IIIC** of dust (conductive dust)

- For hydraulic tools **T5** means that minimum ignition temperature of gas or vapor **>100°C**; **T100°C** means that minimum ignition temperature of a dust cloud $\geq 150^\circ\text{C}$ and minimum ignition temperature of a 5mm dust layer $\geq 175^\circ\text{C}$
- For mechanical tools **T6** means that minimum ignition temperature of gas or vapor **>85°C**; **T85°C** means that minimum ignition temperature of a dust cloud $\geq 127,5^\circ\text{C}$ and minimum ignition temperature of a 5mm dust layer $\geq 160^\circ\text{C}$.

These tools have been designed and manufactured in accordance with the following transposed harmonized European standards:

- **EN ISO 80079-36:2016** Explosive atmospheres - Part 36: Non-electrical equipment for explosive atmospheres - Basic method and requirements;
- **EN ISO 80079-37:2016** Explosive atmospheres - Part 37: Non-electrical equipment for explosive atmospheres - Non-electrical type of protection constructional safety "c", control of ignition sources "b", liquid immersion "k":

▼ SG11TM



- For use on all flange types with bolt-hole sizes ranging from 17,5 mm to 62,0 mm
- Unique expanding collet technology
- Little or no access gap required
- Secure bolt-hole locking mechanism.

OPERATING BENEFITS

- Time-saving, simple operation
- Measurable, controlled flange spreading force
- Virtually universal, the Secure-Grip Flange Spreader range covers ANSI, DIN, SPO, ASME, API and BS flanges.

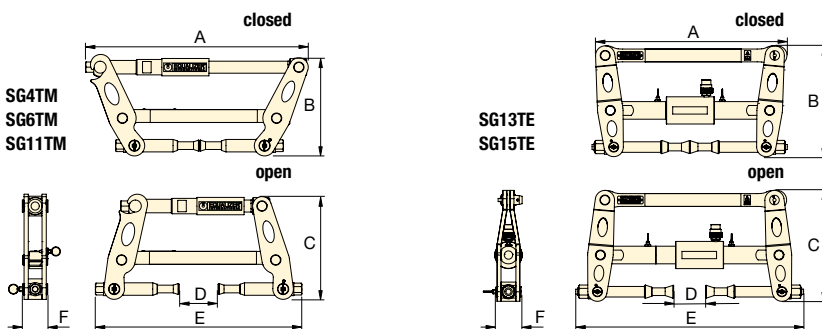

Range of Application

For a detailed range of application please request the Secure-Grip Mechanical or Hydraulic Operator Instruction Sheet.



Caution

A minimum of two Flange Spreading Tools must be used when opening flange joints. This will enable the operator to maintain an equal spreading distance across the flange faces.

Flange Dimensions

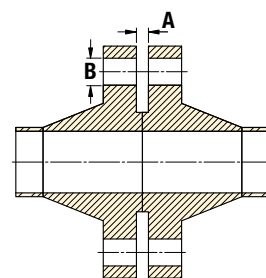

Model Number Tool Kit	Type*	Maximum Spreading Force Per Tool (kN)	Spreading Distance Maximum (mm)	Flange Dimensions (mm)		Tool Dimensions (mm)						Tool Weight (kg)	Kit Weight (kg)	Case Dimensions (mm)	Tool Number
				Minimum Access Gap A	Bolt-hole Diameter B	A	B	C	D	E	F				
SG4TMSTD	M	37,0	75	0	17,5 - 23	398	190	182	75	385	48	4,5	12,8	520x375x165	SG4TM
SG6TMSTD	M	60,0	80	0	24 - 30	468	245	252	80	444	52	7,5	16,0	640x540x165	SG6TM
SG11TMSTD	M	110,0	90	0	30 - 39	516	250	263	90	462	60	10,5	20,0	640x540x165	SG11TM
SG13TESTD	H	130,0	115	0	38 - 49	516	303	314	115	630	72	21,5	40,5	890x570x165	SG13TE
SG15TESTD	H	150,0	100	0	47,5 - 62	600	346	380	100	720	80	26,0	45,0	890x570x165	SG15TE

* M = Mechanical
H = Hydraulic

Flange Spreading Tools

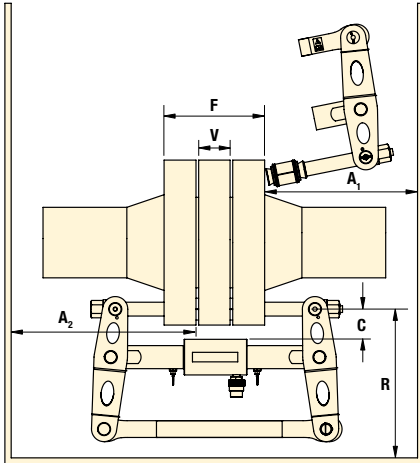

Spreading Force:
37,0 - 150,0 kN

Spreading Distance:
0 - 115 mm

Maximum Operating Pressure:
700 bar *

* Only relevant for hydraulic tools

SG Series



Model Number	Flange Joint Thickness F			Valve / Spacer Thickness V			Flange Clearance C		Radial Space R		Axial Space (for installation) A ₁		Axial Space (installed) A ₂		Tool Number
	Min. (mm)	Max. (mm)	Measured: From / To	Min. (mm)	Max. (mm)	Measured: From / To	Max. (mm)	Measured: From / To	Min. (mm)	Measured: From / To	Min. (mm)	Measured: From / To	Min. (mm)	Measured: From / To	
SG4TMSTD	60	185	Outside face of flange / Outside face of flange	0*	45*	Inside face of flange / Inside face of flange	50	Bolt-hole circle / Largest OD of valve/spacer	170	Bolt-hole circle / Closest obstruction	170	Outside face of flange / Closest obstruction	200	Inner face of flange / Closest obstruction	SG4TM
SG6TMSTD	60	210		0*	50*		55		230		200		234		
SG11TMSTD	96	240		0*	60*		60		240		223		258		
SG13TESTD	120	310		0*	95*		70		280		310		260		
SG15TESTD	140	400		0*	80*		80		370		380		315		

* Short Collet Holder Kits (SCH) are available which can offer improved range of application.

SG4TM MECHANICAL TOOL KIT



- 1 X SG4TM Tool
- 1 X 150 mm Vernier Calliper
- 1 X 3/8" Drive Torque Wrench and 16 mm Socket
- 1 X Safety Block
- 2 X M16 (5/8") Collets
- 2 X M20 (3/4") Collets
- 1 x Aluminium Carry Case with Protective Foam Inserts

SG6TM MECHANICAL TOOL KIT



- 1 X SG6TM Tool
- 1 X 150 mm Vernier Calliper
- 1 X 3/8" Drive Torque Wrench and 21 mm Socket
- 1 X Safety Block
- 2 x M24 (7/8") Collets
- 2 x M27 (1") Collets
- 1 x Aluminium Carry Case with Protective Foam Inserts

SG11TM MECHANICAL TOOL KIT



- 1 X SG11TM Tool
- 1 X 150 mm Vernier calliper
- 1 X 1/2" Drive torque wrench and 24 mm socket
- 1 X Safety block
- 2 x M30 (1-1/8") Collets
- 2 x M33 (1-1/4") Collets
- 2 x M36 (1-3/8") Collets
- 1 x Aluminium Carry Case with Protective Foam Inserts

SG13TE HYDRAULIC TOOL KIT



- 1 x SG13TE Tool
- 1 x 700 bar HP550S Single Port Sealed Hand Pump with Gauge
- 1 x 700 bar Hydraulic Hose, 2 m
- 1 x 150 mm Vernier Calliper
- 1 x 1/2" Square Drive Flexible Handle
- 1 x 30 mm Socket
- 1 x Safety Block
- 2 x M39 (1-1/2") Collets
- 2 x M42 (1-5/8") Collets
- 2 x M45 (1-3/4") Collets
- 1 x Aluminium Carry Case with Protective Foam Inserts

SG15TE HYDRAULIC TOOL KIT



- 1 x SG15TE Tool
- 1 x 700 bar HP550S Single Port Sealed Hand Pump with Gauge
- 1 x 700 bar Hydraulic Hose, 2 m
- 1 x 300 mm Vernier Calliper
- 1 x 1/2" Square Drive Flexible Handle
- 1 x 36 mm Socket
- 1 x Safety Block
- 2 x M48 (1-7/8") Collets
- 2 x M52 (2") Collets
- 2 x M56 (2-1/4") Collets
- 1 x Aluminium Carry Case with Protective Foam Inserts

▼ SG18TE & SG25TE



- Applicable for larger-sized flanges
- Actuated by an external hand pump
- Suitable for bolt holes from 59,5 mm to 108 mm.

SG18TE

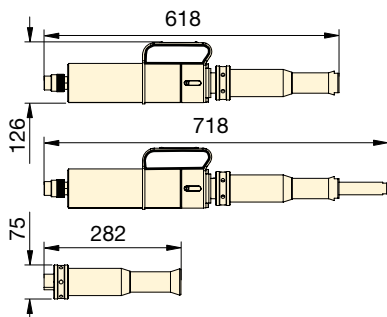

SG25TE

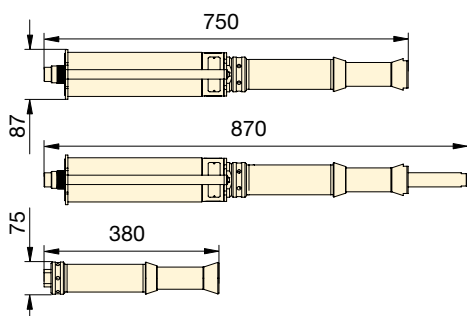

Range of Application

For a detailed range of application please request the Secure-Grip In-Line Hydraulic Operator Instruction Sheet.



Caution

A minimum of two Flange Spreading Tools must be used when opening flange joints. This will enable the operator to maintain an equal spreading distance across the flange faces.

Flange Dimensions

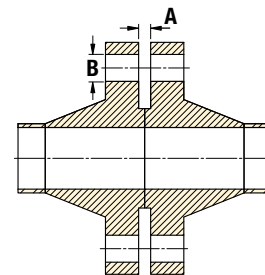

Model Number Tool Kit	Type	Maximum Spreading Force Per Tool (kN)	Spreading Distance Maximum (mm)	Flange Dimensions (mm)		Tool Weight (kg)	Kit Weight (kg)	Case Dimensions (mm)	Tool Number
				Minimum Access Gap A	Bolt-hole Diameter B				
SG18TESTD	Hydraulic	180,0	100	0	59,5 - 75	14	45	890 x 570 x 165	SG18TE
SG25TESTD	Hydraulic	250,0	120	0	75 - 108	24	50	890 x 570 x 165	SG25TE

Flange Spreading Tools

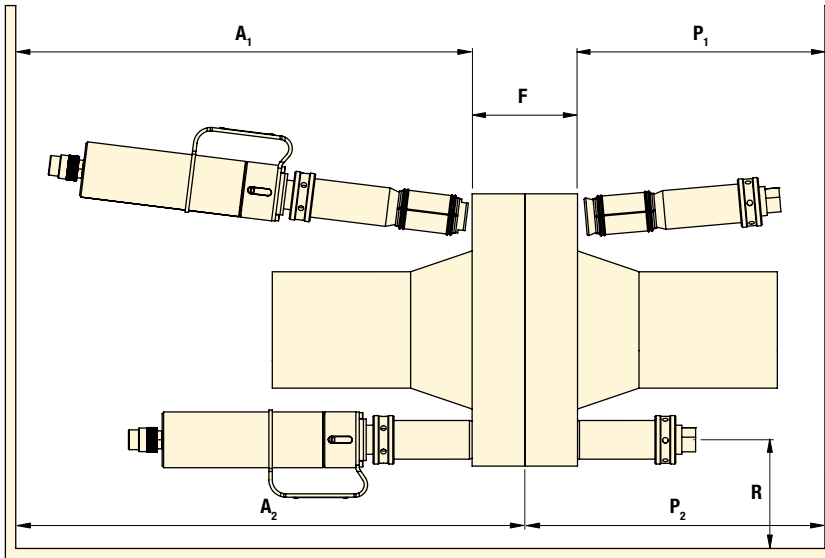

SG Series



Spreading Force:

180,0 - 250,0 kN

Spreading Distance:

0 - 120 mm

Maximum Operating Pressure:

700 bar

Model Number Tool Kit	Flange Joint Thickness F			Radial Space R		Axial Space (for installation) A1		Axial Space (installed) A2		Axial Plug Space (for installation) P1		Axial Plug Space (installed) P2		Tool Number
	Min. (mm)	Max. (mm)	Measured: From / To	Min. (mm)	Measured: From / To	Min. (mm)	Measured: From / To	Min. (mm)	Measured: From / To	Min. (mm)	Measured: From / To	Min. (mm)	Measured: From / To	
SG18TESTD	190	450	Outside face of flange/ Outside face of flange	55	Bolt-hole circle / Closest obstruction	620	Outside face of flange/ Closest obstruction	900	Inner face of flange/ Closest obstruction	283	Outside face of flange/ Closest obstruction	283	Inner face of flange/ Closest obstruction	SG18TE
SG25TESTD	210	570	Outside face of flange/ Outside face of flange	55	Bolt-hole circle / Closest obstruction	750	Outside face of flange/ Closest obstruction	1100	Inner face of flange/ Closest obstruction	380	Outside face of flange/ Closest obstruction	380	Inner face of flange/ Closest obstruction	SG25TE

SG18TE HYDRAULIC TOOL KIT



- 1 x SG18TE Tool
- 1 x Spreading Plug
- 1 x 700 bar HP550S Single Port Sealed Hand Pump with Gauge
- 1 x 700 bar Hydraulic Hose, 2 m
- 1 x 300 mm Vernier Calliper
- 1 x 12.5 mm Spacer Plate
- 1 x 5mm Allen Key
- 1 x 50 mm Spacer
- 1 x Safety Block
- 2 x M60 (2-3/8") Collets
- 2 x M64 (2-1/2") Collets
- 2 x M70 (2-3/4") Collets
- 1 x Aluminium Carry Case with Protective Foam Inserts

SG25TE HYDRAULIC TOOL KIT



- 1 x SG25TE Tool
- 1 x Spreading Plug
- 1 x 700 bar HP550S Single Port Sealed Hand Pump with Gauge
- 1 x 700 bar Hydraulic Hose, 2 m
- 1 x 300 mm Vernier Calliper
- 1 x 12.5 mm Spacer Plate
- 1 x Safety Block
- 1 x Aluminium Carry Case with Protective Foam Inserts

SG25TE COLLETS (AVAILABLE SEPARATELY)

Model Number	Description
673601-01	2 x M76 (3") Collets
674801-01	2 x M90 (3-1/2") Collets
673901-01	2 x M80 (3-1/4") Collets
675101-01	2 x M95 (3-3/4") Collets
674501-01	2 x M84 (3-3/8") Collets
675601-01	2 x M100 (4") Collets

▼ VC10TE



Secure-Grip Valve Change-Out Tools



Caution

A minimum of two Flange Spreading Tools must be used when opening flange joints. This will enable the operator to maintain an equal spreading distance across the flange faces.

- Assists in the removal of wafer/butterfly valves, spades/spacers or gaskets from large flange joints
- Tool span is longer than a standard Secure-Grip Flange Spreader
- Adjustable to enable the tool to operate in a range of situations.



The Actuator and Extension Subassembly can be assembled into 4 different configurations to suit a variety of applications. For a detailed range of application please request the VC10 Operator Instruction Sheet.

PATENTED SECURE-GRIP SYSTEM:

- Unique expanding collet technology
- Secure bolt-hole locking mechanism
- Unique technology makes the Secure-Grip arguably the safest flange spreader available in the world today
- Virtually universal, the Secure-Grip Flange Spreader range will cover ANSI, DIN, Norsok L005, ASME, API and BS Flanges
- Time-saving, simple operation.

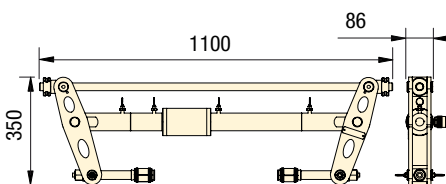

Flange Dimensions

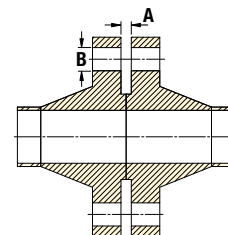

Model Number Tool Kit	Type*	Maximum Spreading Force Per Tool (kN)	Spreading Distance Maximum (mm)	Flange Dimensions (mm)		Tool Kit Weight (kg) (2 per Maxi Kit)	Pump Kit Weight (kg)	Gross Kit Weight (kg)	Tool Case Dimensions (mm)	Pump Case Dimensions (mm)	Tool Number
				Minimum Access Gap A	Bolt-hole Diameter B						
VC10/13TESTD	H	100	580	0	38 - 49	50	27	77	550x1200x170	550x1200x170	VC10/13TE
VC10/13TEMAX	H	100	580	0	38 - 49	50	30	130	550x1200x170	550x1200x170	VC10/13TE
VC10/15TESTD	H	100	560	0	47,5 - 62	53	27	80	550x1200x170	550x1200x170	VC10/15TE
VC10/15TEMAX	H	100	560	0	47,5 - 62	53	30	136	550x1200x170	550x1200x170	VC10/15TE
VC10/18TESTD	H	100	514	0	59,5 - 75	58	27	85	550x1200x170	550x1200x170	VC10/18TE
VC10/18TEMAX	H	100	514	0	59,5 - 75	58	30	146	550x1200x170	550x1200x170	VC10/18TE
VC10/25TESTD	H	100	490	0	75 - 108	58	27	85	550x1200x170	550x1200x170	VC10/25TE
VC10/25TEMAX	H	100	490	0	75 - 108	58	30	146	550x1200x170	550x1200x170	VC10/25TE

* H = Hydraulic

Flange Spreading Tools

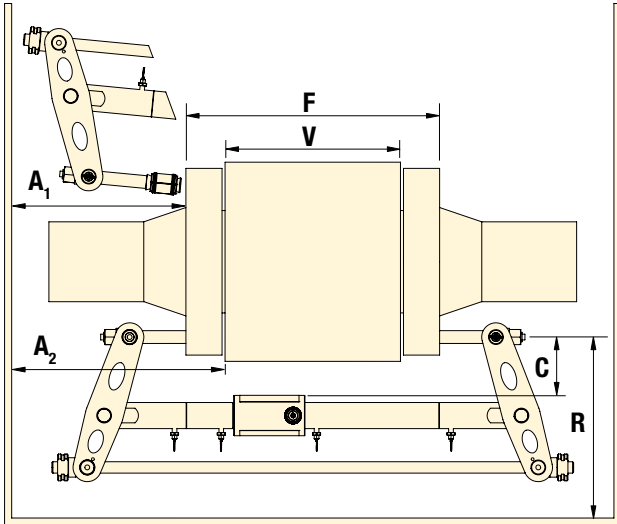

VC Series



Spreading Force:
100 kN

Spreading Distance:
0 - 580 mm

Maximum Operating Pressure:
700 bar

Model Number Tool Kit	Flange Joint Thickness F			Valve / Spacer Thickness V			Flange Clearance C	Radial Space R	Axial Space (for installation) A ₁	Axial Space (installed) A ₂	Tool Number
	Min. (mm)	Max. (mm)	Measured: From / To	Min. (mm)	Max. (mm)	Measured: From / To	Measured: From / To	Measured: From / To	Measured: From / To	Measured: From / To	
VC10/13TESTD	110	690	Outside face of flange / Outside face of flange	0*	580*	Inside face of flange / Inside face of flange	Bolt-hole circle / Largest OD of valve/spacer - max. 130 mm	Bolt-hole circle / Closest obstruction - min. 360 mm	Outside face of flange / Closest obstruction - min. 300 mm	Inner face of flange / Closest obstruction - min. 370 mm	VC10/13TE
VC10/13TEMAX	110	690		0*	580*						VC10/13TE
VC10/15TESTD	130	690		0*	560*						VC10/15TE
VC10/15TEMAX	130	690		0*	560*						VC10/15TE
VC10/18TESTD	176	690		0*	514*						VC10/18TE
VC10/18TEMAX	176	690		0*	514*						VC10/18TE
VC10/25TESTD	200	690		0*	490*						VC10/25TE
VC10/25TEMAX	200	690		0*	490*						VC10/25TE

* Short Collet Holder Kits (SCH) are available which can offer improved range of application.

TOOL KITS (1 PER STD KIT, 2 PER MAX KIT)



VC10/13TE

1 x VC10/13TE Tool
2 x M39 (1-1/2") Collets
2 x M42 (1-5/8") Collets
2 x M45 (1-3/4") Collets
1 x Aluminium Carry Case with Protective Foam Inserts

VC10/15TE

1 x VC10/15TE Tool
2 x M48 (1-7/8") Collets
2 x M52 (2") Collets
2 x M56 (2-1/4") Collets
1 x Aluminium Carry Case with Protective Foam Inserts

VC10/18TE

1 x VC10/18TE Tool
2 x M60 (2-3/8") Collets
2 x M64 (2-1/2") Collets
2 x M70 (2-3/4") Collets
1 x Aluminium Carry Case with Protective Foam Inserts

VC10/25TE

1 x VC10/25TE Tool
1 x Aluminium Carry Case with Protective Foam Inserts

PUMP KITS



For STD Tool Kits

1 x 700 bar HP550S Single Port Hydraulic Hand Pump
1 x Hydraulic Gauge with Manifold
1 x 700 bar Hydraulic Hose, 2,0 m
1 x Secure Grip Safety Block
1 x Square Drive Flexible Handle
1 x Vernier Calliper
1 x Aluminium Carry Case with Protective Foam Inserts

For MAX Tool Kits

1 x 700 bar HP1000D Twin Port Hydraulic Hand Pump
2 x Hydraulic Gauges with Manifolds
2 x 700 bar Hydraulic Hoses, 2,0 m
2 x Secure Grip Safety Blocks
1 x Square Drive Flexible Handle
1 x Vernier Calliper
1 x Aluminium Carry Case with Protective Foam Inserts



Collet Sizing

It is important that the correct size of collet is used. An undersized collet could allow the collet holder to pull through its bore. An oversized collet has the potential to become jammed in the bolt-hole.



Range of Application

For a detailed range of application please request the Hydraulic Secure-Grip Valve Change-Out Tool Operator Instruction Sheet.

VC10/25TE COLLETS (AVAILABLE SEPARATELY)

Model Number	Description
673601-01	2 x M76 (3") Collets
673901-01	2 x M80 (3-1/4") Collets
674501-01	2 x M84 (3-3/8") Collets
674801-01	2 x M90 (3-1/2") Collets
675101-01	2 x M95 (3-3/4") Collets
675601-01	2 x M100 (4") Collets

▼ TFA15TI



TFA Series

WIND TURBINE TOWER FLANGE ALIGNMENT TOOLS

Hook Force:
40 - 270 kN

Aligning Distance:
42 - 65 mm

TFA4TM Mechanical Tool Kit



- 1 x TFA4TM Tool
- 1 x Torque Wrench
- 1 x Moulded Plastic Carry Case

TFA12TE / TFA15TE External Hydraulic Tool Kit



- 1 x TFA12TE or TFA15TE Tool
- 1 x Safety Lanyard
- 1 x Aluminium Carry Case with Protective Foam Inserts

TFA12TI / TFA15TI Internal Hydraulic Tool Kit



- 1 x TFA12TI or TFA15TI Tool
- 1 x Aluminium Carry Case with Protective Foam Inserts

The TFA Wind Turbine Tower Flange Alignment Tools have been developed to aid the alignment of large flanges on the inside of wind turbine towers during their assembly or installation.

- Assists in aligning / de-ovalizing large internal pipe flanges
- Helps resolve bolt-hole misalignment within tower sections of wind turbine towers
- Can be used both on and offshore.

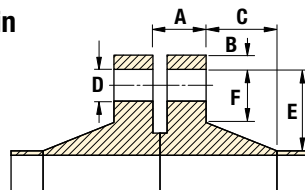

Flange Dimensions

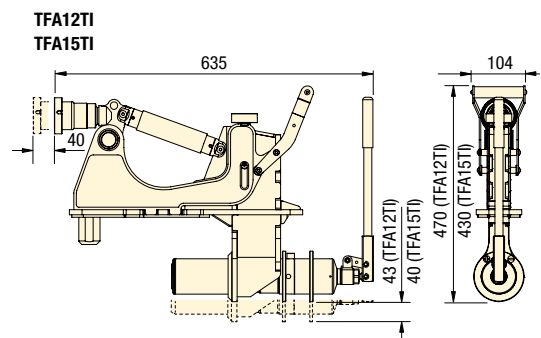
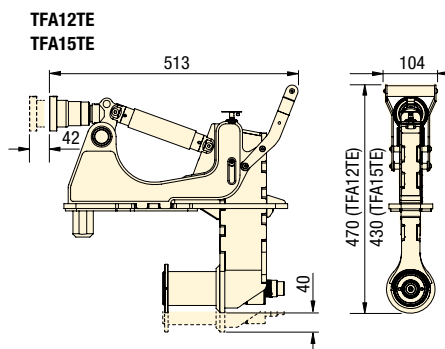
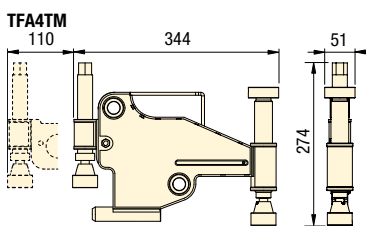

Model Number Tool Kit	Type*	Maximum Hook Force Per Tool (kN)	Maximum Aligning Distance (mm)	Maximum Operating Pressure (bar)	Flange Dimensions (mm)						Tool Weight (kg)	Kit Weight (kg)	Box/Case Dimensions (mm)	Tool Number
					A	B	C	D min	E	F min				
TFA4TMSTD	M	40	42	-	36-135	0-55	0-231	25	0-105	24	8,1	18,0	600x370x200	TFA4TM
TFA12TEMIN	H	240	65	510	129-178	110-241	0-167	45	87-125	62	19,3	28,4	640x540x165	TFA12TE
TFA15TEMIN	H	270	65	700	89-138	110-241	0-167	45	87-125	62	18,9	28,0	640x540x165	TFA15TE
TFA12TIMIN	H	240	65	-	129-178	113-241	0-167	45	87-125	62	21,9	31,0	585x900x160	TFA12TI
TFA15TIMIN	H	270	65	-	89-138	113-241	0-167	45	87-125	62	21,5	30,6	585x900x160	TFA15TI

* M = Mechanical
H = Hydraulic

Flange Pulling Tools

▼ FC10TE



- Applicable to all flanges with a bolt-hole diameter of 1 inch or greater, including ANSI, DIN, Norsok L005, ASME and BS flanges
- Slide and lock collet system
- Low profile tool
- Can be used on all vertical and horizontal flanges including ANSI, API, BS, DIN & Norsok L005
- Robust yet light weight
- Subsea compatible
- Reciprocating hydraulic action.

OPERATING BENEFITS

- Reduction in operator fatigue
- Reduction in pinch point
- Quick and easy to use.

Flange Dimensions

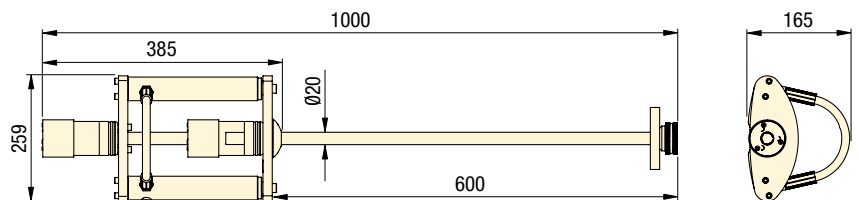
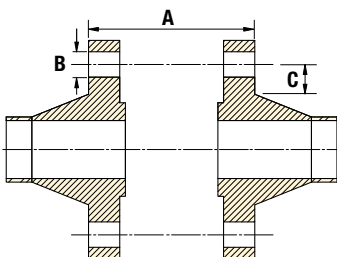

FC Series

FLANGE CLOSING TOOLS

Closing Force:
100 kN

Closing Distance:
570 - 0 mm

Maximum Operating Pressure:
700 bar



Caution

A minimum of two flange closing tools must be used when flange pulling. This will enable the operator to maintain an even gap between flange faces and prevent flange / gasket damage.

FC10TESTD STD Kit



- 1 x FC10TE Tool
- 1 x 700 bar Hydraulic Hose, 2 m long
- 1 x 700 bar HP550S Single Port Sealed Hand Pump with Gauge
- 1 x Aluminium Carry Case with Protective Foam Inserts

FC10TEMAX MAX Kit



- 2 x FC10TE Tool
- 2 x 700 bar Hydraulic Hoses, 2 m long
- 1 x 700 bar HP550D Twin Port Sealed Hand Pump with Gauge
- 1 x Aluminium Carry Case with Protective Foam Inserts

Model Number Tool Kit	Type	Maximum Closing Force Per Tool (kN)	Closing Distance (mm)	Flange Dimensions (mm)			Tool Weight (kg)	Kit Weight (kg)	Box/Case Dimensions (mm)	Tool Number
				A	B min	C min				
FC10TESTD	Hydraulic	100	570	16-570	25,4*	32	11	23,5	890 x 570 x 165	FC10TE
FC10TEMAX	Hydraulic	100	570	16-570	25,4*	32	11	36,5	890 x 570 x 165	FC10TE

* For hole diameter greater than 45mm, please contact Enerpac.

▼ HP350DMIN



- HP-S, HP-D and HP-SD pump ranges are operable at all angles and are highly resistant to accidental spillage of hydraulic fluid. (certified)
- The Single-Port and Twin-Port Hand Pumps are also available with ATEX rating, which are certified for use in hazardous areas II 2G Ex h IIB T5 Gb, II 2D Ex h IIIC T100°C Db.

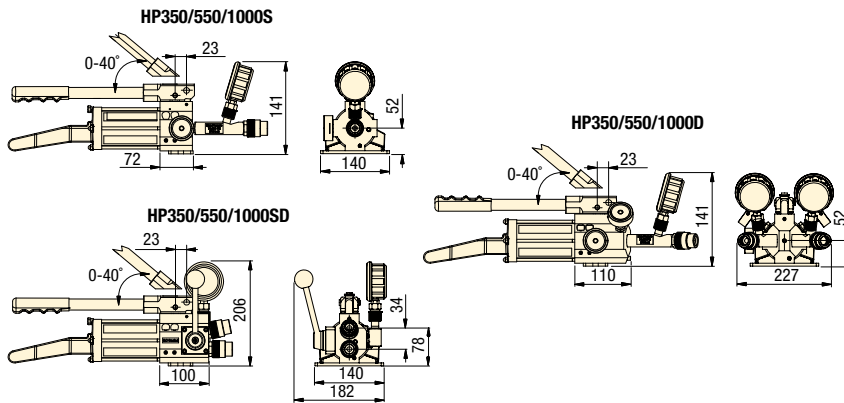

HP Series



**HYDRAULIC SEALED
HAND PUMPS**

Maximum Pressure Rating:

**1st Stage: 13,8 bar
2nd Stage: 700 bar**

Pump Type:

2-Speed



Pump Ratings

The Hydraulic Single Port, Twin Port and Double-Acting Hand-Pump (and hoses) are tailored for use with hydraulic equipment. Each pump's output is regulated to 700 bar and is delivered from threaded 3/8" NPT output ports. The pumps and hoses can be used with any 700 bar rated hydraulic equipment within their oil capacity specification. The HP range of hydraulic hand-pumps have been designed with a seal oil reservoir, which allows the pumps to be used in any orientation without the risk of oil spills or air contamination

700 BAR HOSES

AVAILABLE TO PURCHASE SEPARATELY

Model Number	Description
302701-01	HYDRAULIC HOSE 2M
302702-01	HYDRAULIC HOSE 4M
302705-01	HYDRAULIC HOSE 3M
302706-01	HYDRAULIC HOSE 5M
302707-01	HYDRAULIC HOSE 6M
1440008-01	ATEX HYDRAULIC HOSE 2M
1440013-01	ATEX HYDRAULIC HOSE 4M
1440014-01	ATEX HYDRAULIC HOSE 6M

Model Number Hand Pump Kit		Type*	Nominal Oil Capacity (cc)	Useable Oil Capacity (cc)	Oil Volume per Stroke (cc)		Max. Handle Effort (kgf)	Piston Stroke (mm)	Overall Length (mm)	Box Dimensions (mm)	Pump Weight (kg)	Kit Weight (kg)	Tool Number
Standard	ATEX				1st Stage	2nd Stage							
HP350SMIN	HP350SMINEX	SA, SP	350	300	3,62	0,77	33	18	554	250 x 180 x 600	4,4	4,9	HP350S
HP550SMIN	HP550SMINEX	SA, SP	550	580	3,62	0,77	25	18	643	250 x 180 x 700	5,1	5,9	HP550S
HP1000SMIN	HP1000SMINEX	SA, SP	1000	1110	3,62	0,77	21	18	867	250 x 180 x 900	6,1	7,1	HP1000S
HP350DMIN	HP350DMINEX	SA, TP	350	300	3,62	0,77	33	18	580	250 x 180 x 600	6,5	7,2	HP350D
HP550DMIN	HP550DMINEX	SA, TP	550	580	3,62	0,77	25	18	669	250 x 180 x 700	7,2	8,1	HP550D
HP1000DMIN	HP1000DMINEX	SA, TP	1000	1110	3,62	0,77	21	18	893	250 x 180 x 900	7,1	9,3	HP1000D
HP350SDMIN	-	DA	350	300	3,62	0,77	33	18	456	250 x 180 x 600	5,3	5,7	HP350SD
HP550SDMIN	-	DA	550	580	3,62	0,77	25	18	579	250 x 180 x 700	5,7	6,0	HP550SD
HP1000SDMIN	-	DA	1000	1110	3,62	0,77	31	18	769	250 x 180 x 900	5,9	6,3	HP1000SD

* SA = Single Acting DA = Double Acting
 SP = Single Port TP = Twin Port

Product Training and Demonstration



Product training

Equalizer designs and builds products of the highest quality, using the best components. This quality ethos extends to training and a range of training components are offered to ensure the optimal use of the tools. In addition to online training materials, Equalizer has a hands-on training facility, class-room based training and an onsite training system with a mobile demo trailer which travels around providing on-site introductions and training. Through this, users can experience first-hand how quick, simple and easy the tools are to apply and use on a series of custom-built flanges.

Class-room based training

Commercial and technical presentations provide distributors with the necessary information to respond to a wide range of customer enquiries and challenges.



On-site training

- Custom built trailer, containing the full range of Equalizer™ tools
- Portable training rig with flange joints
- Flange aligning, spreading and pulling tool demonstrations.

Hands-on training and demonstration

Practical demonstrations and hands-on training provide distributors and customers with valuable knowledge, information and experience to safely use the full range of Equalizer products. This in turn strengthens Equalizer's reputation as the expert in tools for flange maintenance within the oil and gas, chemical, power generation, nuclear, water, mining and renewable energy sectors world-wide.



For the toughest on-site machining jobs



▲ *Flange facing machining.*

FLANGE FACING MACHINES

If you mention flange facing machines to an on-site machinist, the chances are the first manufacturer they'll think of is Mirage. This success stems from their precision construction, the results they deliver, and how easy they are to set-up on-site. Choose from external and internal mount options in a wide range of sizes.

LINEAR MILLING MACHINES

These are available in 2 and 3 axis configurations. Each includes the latest workshop tool technology in a portable format. Choose our optional switch magnets and chain clamps for a fast and efficient set-up onto pipe diameters.

ORBITAL MILLING MACHINES

Mirage orbital milling machines deliver fast material removal and achieve high accuracy across large diameters. The WP orbital milling range is designed especially for companies manufacturing wind turbine rotor blades and towers.

HOT TAPPING MACHINES

Hot tapping is a high pressure intervention and the Mirage range of machines can help you achieve a safe and effective solution. Innovations used include a helical gear drive located close to the cutting head to ensure maximum efficiency, rotary pressure seals, and four fixed feeds.

Portable machine tools to power your success

Decades of engineering knowhow combined with a continuing drive to innovate has resulted in a wide range of world-class portable machining products - each one robust enough to handle the toughest of on-site machining challenges.



▲ *Flange facing machines to ensure flange joint integrity.*



▲ *Orbital milling machines used in shipbuilding and power generation industries.*



▲ *Orbital milling machines for wind turbine manufacture.*

Our mission is to help you create success stories, for both you and your customers



▲ Pipe cutters and weld preparation.

LINE BORING MACHINES

Mirage Line Boring Machines produce workshop quality tolerances on site - eliminating costly dismantling and production downtime. Many configurations are possible by choosing different bar diameters and lengths, along with a wide range of inserts, boring arms and facing heads.

DECOMMISSIONING SAWS

Mirage provides a range of saws for a diverse range of heavy duty tubular severance projects. Band saws deliver a cost effective solution to cold cutting requirements and our diamond wire saws are ideal for quickly cutting through dissimilar materials.

DRILLING AND TAPPING MACHINES

Mirage heavy duty drilling and tapping machines offer high torque and easy operation through their heavy duty spindles with ISO standard tapers. Optional switch magnet mounts and chain clamps enable a quick and easy setup. For large scale offshore decommissioning projects Mirage casing pin drills provide an effective solution for creating lift holes in casings.

DL RICCI CLAMSHELL CUTTERS

Throughout the world, the DL Ricci name is synonymous with pipe cutting and bevelling. Mirage is now able to offer these pioneering machines, each capable of delivering an outstanding performance in industries such as construction, decommissioning, maintenance, fabrication and refurbishment.

High Performing Portable Machine Tools

Creating machines to deal with the toughest machining challenges doesn't just happen by accident. It comes from decades of engineering know-how, from the relentless need to innovate - and above all, from placing the customer at the heart of everything we do.



▲ Pipe cutters and weld preparation.



▲ Line boring machines for power generation and maintenance of construction vehicles.



▲ High torque portable drilling machines.

▼ Shown: MITT6A, MITT16A, MITT2A, MITT1A Isolation & Test Tools



Ultimate Versatility in Piping Isolation and Pressure Testing



Inline Isolation & Test Tools

MITT series tools obsolete traditional pipe cleaning and hydrotesting methods used for maintenance and construction operations.

Improve operator safety and reduce system downtime by eliminating cleaning requirements and limiting test pressure volume.

The MITT series tools improve safety by limiting the test pressure volume and reduce downtime by eliminating cleaning requirements.

Key benefits of the tools include:

- Significantly reduce maintenance project timelines
- Safely perform welding on hydrocarbon lines with the peace of mind of a positive pressurized hydrostatic isolation
- Achieve significant reduction in wastewater (<1,0 litres of water required for a 24 inch test)
- Patent Pending.

- **Combination Isolation and Test Tool assures vapor-free isolation for hot work and high-pressure capability between seals for testing welds with one tool**
- **Multi-schedule capability – up to 6 schedules covered per tool, 40 tools cover 154 pipe diameter / schedule combinations**
- **Lightweight, slim and versatile design – no crane required, able to mount in elbows and tees, able to test mismatched schedules**
- **High-pressure capability – test welds with relative ease up to 310 bar**
- **Self-centering tools are user-friendly and require minimal training**
- **Hydrodynamic capability for heat treating.**

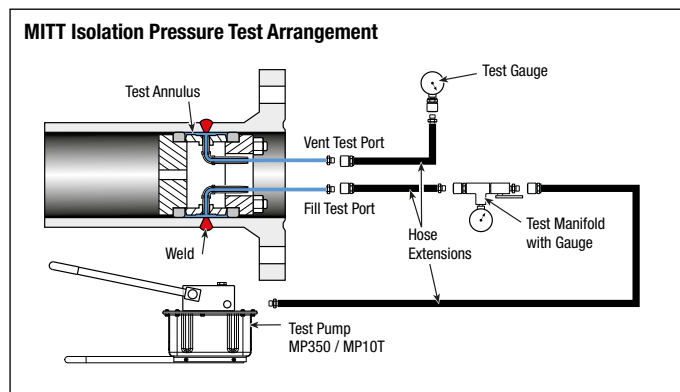
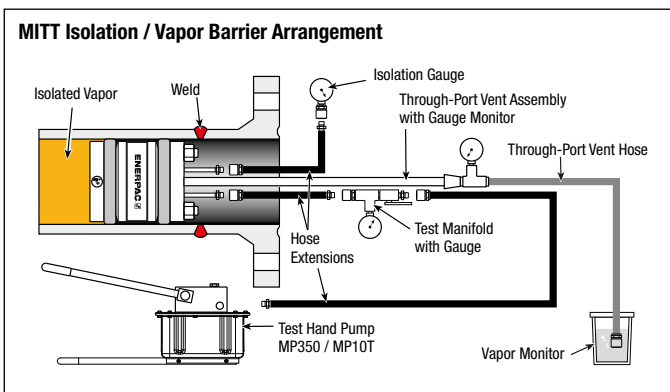

Nominal Pipe Diameter	Model Number	Pipe Schedules Covered	Max. Tool Pressure Rating	Tool Body Diameter	Overall Length	Stud, Nut, Washer Size	Pressure Port Size	
(inch)			(bar)	(mm)	(mm)	(inch)	(ASME NPT)	(kg)
3/4	MITT075A	5, 10, STD/40	310	18	356	1/8"	Female 1/8"	0,7
	MITT075B	XS/80, 160	310	15	356	1/8"	Female 1/8"	0,7
1	MITT1A	5, 10, STD/40	310	23	356	1/8"	Female 1/8"	0,9
	MITT1B	XS/80, 160	310	18	356	1/8"	Female 1/8"	0,7
1 1/4	MITT125A	5, 10, STD/40 XS/80	310	29	356	1/4"	Female 1/4"	1,3
1 1/2	MITT150A	5,10, XS/80	310	35	356	1/4"	Female 1/4"	1,9
	MITT150B	160	310	28	356	1/4"	Female 1/4"	1,5
2	MITT2A	5,10, STD/40, XS/80	310	46	356	1/4"	Female 1/4"	2,4
	MITT2B	160, XXS	310	37	356	1/4"	Female 1/4"	2,0
3	MITT3A	5,10, STD/40, XS/80	310	71	178	3/8"	Male 1/8"	2,3
	MITT3B	160, XXS	310	57	178	3/8"	Male 1/8"	2,0
4	MITT4A	5,10, STD/40, 60, XS/80	310	94	178	5/16"	Male 1/8"	2,5
	MITT4B	120, 160	310	81	178	5/16"	Male 1/8"	2,2
	MITT4C	XXS	310	77	178	5/16"	Male 1/8"	1,9
6	MITT6A	10, STD/40, 60	310	145	178	5/8"	Male 1/4"	5,9
	MITT6B	XS / 80, 120	310	137	178	5/8"	Male 1/4"	5,4
	MITT6C	160, XXS	310	122	178	5/8"	Male 1/4"	4,5
8	MITT8A	10, 20, 30, STD/40, XS/80	310	189	178	5/8"	Male 1/4"	8,6
	MITT8B	100, 120, 140, XXS, 160	310	168	178	5/8"	Male 1/4"	7,3
10	MITT10A	20, 30, STD/40, XS/60, 80	310	238	178	5/8"	Male 1/4"	13,2
	MITT10B	100, 120, XXS/140, 160	310	213	178	5/8"	Male 1/4"	11,3
12	MITT12A	10, 20, 30, STD, 40, XS	310	294	178	5/8"	Male 1/4"	19,5
	MITT12B	60, 80, 100, XXS/120	310	272	178	5/8"	Male 1/4"	18,6
	MITT12C	140, 160	310	248	178	5/8"	Male 1/4"	14,5
14	MITT14A	10, 20, STD/30, 40	310	324	178	5/8"	Male 1/4"	20,4
	MITT14B	XS, 60, 80	310	324	178	5/8"	Male 1/4"	19,1
	MITT14C	100, 120, 140, 160	310	283	178	5/8"	Male 1/4"	17,2
16	MITT16A	10, 20, STD/30, XS/40, 60	310	372	178	5/8"	Male 1/4"	24,5
	MITT16B	80, 100	310	344	178	5/8"	Male 1/4"	21,8
	MITT16C	120, 140, 160	310	324	178	5/8"	Male 1/4"	20,4
18	MITT18A	10, 20, STD, 30, XS, 40	310	419	178	5/8"	Male 1/4"	29,0
	MITT18B	60, 80	310	400	178	5/8"	Male 1/4"	27,2
	MITT18C	100, 120	310	378	178	5/8"	Male 1/4"	24,9
	MITT18D	140, 160	310	357	178	5/8"	Male 1/4"	23,6
20	MITT20A	10, STD/20, XS / 30	310	480	178	5/8"	Male 1/4"	36,3
	MITT20B	40, 60	310	457	178	5/8"	Male 1/4"	33,1
	MITT20C	80, 100	310	433	178	5/8"	Male 1/4"	30,4
	MITT20D	120, 140	310	410	178	5/8"	Male 1/4"	27,7
	MITT20E	160	310	399	178	5/8"	Male 1/4"	27,2
22	MITT22A	STD, XS	310	524	178	5/8"	Male 1/4"	40,4
	MITT22B	60, 80	310	492	178	5/8"	Male 1/4"	36,7
	MITT22C	100, 120	310	467	178	5/8"	Male 1/4"	34,0
	MITT22D	140, 160	310	441	178	5/8"	Male 1/4"	31,3
24	MITT24A	10, STD/20, XS, 30	79	575	178	5/8"	Male 1/4"	44,9
	MITT24B	40, 60	155	551	178	5/8"	Male 1/4"	42,6
	MITT24C	80, 100	232	522	178	5/8"	Male 1/4"	39,9
	MITT24D	120, 140	310	495	178	5/8"	Male 1/4"	37,2
	MITT24E	160	310	480	178	5/8"	Male 1/4"	36,3
26	MITT26A	10, STD, XS	79	626	178	5/8"	Male 1/4"	52,2
30	MITT30A	10, STD, XS/20, 30	79	727	178	5/8"	Male 1/4"	66,7
	MITT30B	40	79	714	178	5/8"	Male 1/4"	63,5
32	MITT32A	10, STD, XS/20, 30	79	778	178	5/8"	Male 1/4"	71,7
	MITT32B	40	79	768	178	5/8"	Male 1/4"	70,3
34	MITT34A	10, STD, XS/20, 30	29	829	178	5/8"	Male 1/4"	76,2
	MITT34B	40	29	819	178	5/8"	Male 1/4"	74,8
36	MITT36A	10, STD, XS	29	879	178	5/8"	Male 1/4"	84,8
38	MITT38A	STD, XS	29	930	178	5/8"	Male 1/4"	94,3
40	MITT40A	STD, XS	29	981	178	5/8"	Male 1/4"	104,3

MITT Series



Pipe Diameters:

3/4 - 40 inch

Water Capacity per Test:

0,4 - 3,0 litres

Maximum Test Pressure:

310 bar



Cost-Effective Spares

Buna 90 shore hardness seals and stainless steel seal backing rings provide additional pressure capacity for a low cost.



Ancillary Kit - MITTAK

All ancillary components required to safely isolate piping and test new welds (includes manual valves, gauge set, hoses, hand tools, fittings).



Pump and Reservoir

To match the full capability of the tools, the **MP350** hand pump and **MP10T** reservoir are recommended.

▼ MITT2A tool being torqued in a test stand for high pressure testing.





Enerpac 'Yellow Pages' stand for technical information!

If selecting bolting tools is not your daily routine, then you will appreciate these pages. The 'Yellow Pages' are designed to help you work with hydraulics. They will help you to better understand the basics of bolting system set-ups and of the most commonly used bolting techniques.

The better your choice of equipment, the better you will appreciate these tools. Take the time to go through these 'Yellow Pages' and you will benefit even more from Enerpac Bolting Solutions.



Enerpac Warranty Statement

Visit our web site for the complete Global Lifetime Warranty or call your Authorized Service Center.

Section		Page
Safety Instructions		134 ▶
Bolting Theory		136 ▶
Torque Tightening		138 ▶
Tensioning		140 ▶
Bolting Integrity Software		142 ▶
Hexagon Bolt and Nut Sizes Key to measurement		144 ▶ 145 ▶
Bolting Service & Safety		146 ▶
Enerpac Academy		147 ▶
About Enerpac		148 ▶

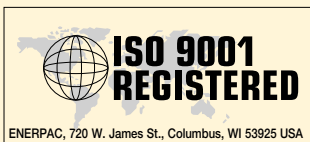

Enerpac is certified for several quality standards. These standards require compliance with standards for management, administration, product development and manufacturing. Enerpac worked hard to earn the quality rating ISO 9001, in its ongoing pursuit of excellence.

DIN-ISO 1402

Enerpac Thermoplastic and Rubber Hoses have been tested and confirm to this Standard.

ASME B30.1-2015

Our cylinders fully comply with the criteria set forth by the American National Standards Institute (except RD, BRD, HCL, LPL, CUSP and JHA-Series)

Product Design Criteria

All hydraulic components are designed and tested to be safe for use at maximum 700 bar (10.000 psi) pressure unless otherwise specifically noted.



Where specified, Enerpac electric power units meet the design, assembly and test requirements of the Standards Council of Canada (CAN C22.2 No. 68-92), and UL73 for the United States. Units were tested and certified for both USA and Canada by TÜV and by CSA, USA-OSHA-NRTLs., (Nationally Recognised Testing Laboratories.)

EMC Directive

Where specified, Enerpac electric power pumps meet the requirements for Electromagnetic Compatibility per EMC Directive 2014/30/EU.



CE Marking & Conformity

Enerpac provides Declarations of Conformity or Incorporation, as applicable, and CE Marks for products according to the EU Directives.



ATEX 95 Certified

The S, W, DSX and HMT-Series torque wrenches, ZA, XA, LAT and ATP-Series air driven pumps, SWI-Ex-flange spreaders, HP-Ex hand pumps and the 144-type hoses are tested and certified to conform to the Directive 2014/34/EU "ATEX Directive". The explosion protection is for Equipment Group II, Equipment Category 2 (Hazardous Zone Area 1) in Gas and/or Dust atmospheres.

- S, W-wrenches: **Ex II 2 GD T4**
- DSX, HMT-wrenches: **Ex II 2 G c T6**
- NSH-Nut Splitters: **Ex II 2 G c T6**
- ZA4, ZA4T-Air Pumps: **Ex II 2 GD ck T4**
- ZA4TX-QROP-Pump: **Ex IIC T4 Gc**
Ex IIIC T135°C Dc
- ATP, XA-Air Pumps: **Ex II 2 GD ck T4**
- LAT-Air Pumps: **Ex IIC T4 Gc** and **Ex IIIC T135°C Dc**
- SWI-Ex Spreaders: **II 2G Ex h IIB T5 Gb** and **II 2D Ex h IIIC T85°C Db**
- HP-Ex Hand Pumps: **II 2G Ex h IIB T5 Gb** and **II 2D Ex h IIIC T100°C Db**
- 144-Hoses: **II 2G Ex h IIB T5 Gb** and **II 2D Ex h IIIC T100°C Db**

Bolting Solution and Application Worksheet



Please complete the following information prior contacting Enerpac for your bolting proposal:

Requested By: _____
 Requested Date: _____
 Company: _____
 Industry: _____
 Contact: _____
 Title: _____
 Phone: _____
 Fax: _____
 Email: _____

Description of Application (provide drawings if possible):

Type of Application:

APPLICATION TECHNICAL DATA

Bolt Quantity: _____
 Bolt Diameter: _____
 Bolt Threads per Inch/Pitch: _____
 Bolt Grade: _____
 Bolt Coating: _____
 Gasket Type: _____
 Appl. Operating Temperature, °C or °F: _____

Application Position:

Top-side Vertical Inverted

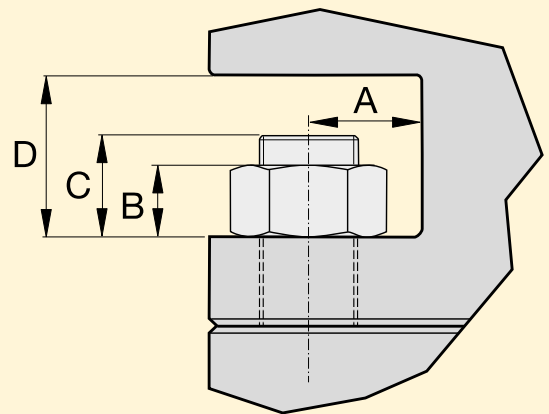
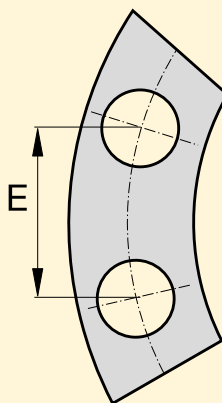

Known Bolting Values:

Load
 (kN / lbs) _____ % of Yield (N/mm² / psi)

Stretch-Bolt Length
 (mm / inch) _____

Turn of Nut
 (Preload / Degrees) _____

Torque
 (Nm / Kgm / Ft.lbs) _____

Specify Dimensions:	INCH	MM (Metric)
A _____ B _____ C _____ D _____ E _____		
Distance to Closure: _____		
Current Lubrication: Type _____ Brand _____		



Safety Instructions



When used correctly, hydraulic power is one of the safest methods of applying force to your work. And to that end we offer some DO's and DON'Ts, simple common sense points which apply to practically all Enerpac hydraulic products.

- Lift slowly and check the load often
- Avoid standing in the line of force
- Anticipate possible problems and take steps to avoid them.

The line drawings and application photo's of Enerpac products throughout this catalog are used to portray how some of our customers have used hydraulics in industry.

In designing similar systems, care must be taken to select the proper components that provide safe operation and fit your needs.

Check to see if all safety measures have been taken to avoid the risk of injury and property damage from your application or system.

Enerpac can not be held responsible for damage or injury, caused by unsafe use, maintenance or application of its products.

Please contact the Enerpac office or a representative for guidance when you are in doubt as to the proper safety precautions to be taken in designing and setting up your particular system.

In addition to these tips, every Enerpac product comes with instructions spelling out specific safety information. Please read them carefully.

Bolting Tools

		Always use the proper personal protection equipment (PPE).			Never stand in-line with the bolt axis.
		Always check your system set-up and follow the correct bolting procedures.			Never stand in-line with the flange or pipe opening.
		Never stand in-line with the pressure, couplers or hoses.			Never hold pressurized hoses.
		The torque wrench (or tool) operator is always in charge.			Hold torque wrench (or tool) at handle only. Do not place any part of body between wrench and reaction point.

Cylinders

		Provide a solid support for the entire cylinder base area. Use cylinder base attachment for more stability.			As with jacks, never place any part of your body under the load. Load must be on cribbing before venturing under.
--	--	---	--	--	---



General

80% Manufacturer's rating of load and stroke are maximum safe limits. **80%**
Good practice encourages using only 80% of these ratings!

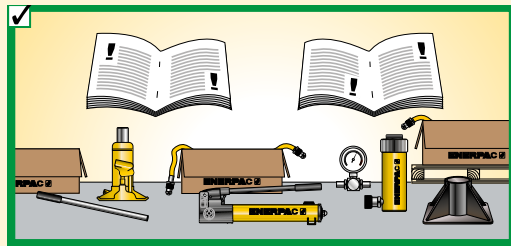

Always read instructions and safety warnings that come with your Enerpac hydraulic equipment.

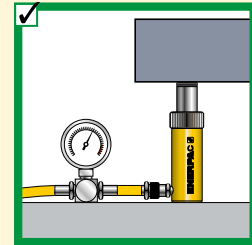
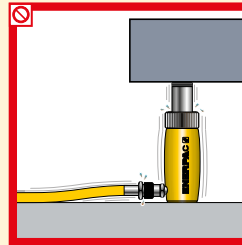

Don't override the factory setting of relief valves. Always use a gauge to check system pressure.

Pumps

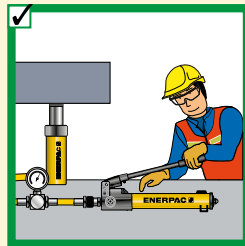
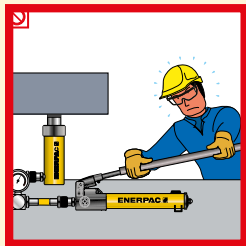

Don't use handle extenders. Hand pumps should be easy to operate when used correctly.

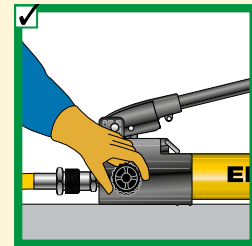
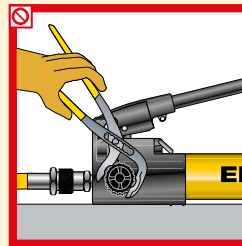

Close release valve finger tight. Using force will ruin the valve.

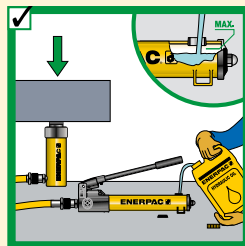
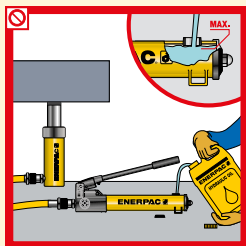

Fill pump only to recommended level. Fill only when connected cylinder is fully retracted.

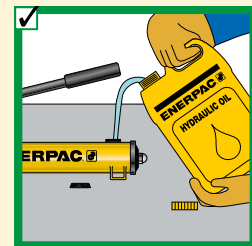
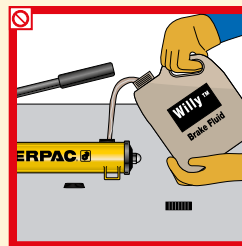

Use only genuine Enerpac hydraulic oil. Wrong fluid can destroy seals and pump and will render your warranty null and void your guarantee.

Hoses and couplers

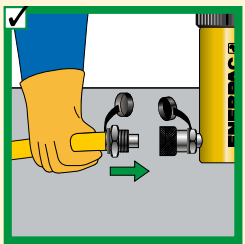
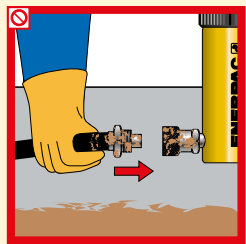

Clean both coupler parts before connecting. Use dust caps when coupler parts are not connected.

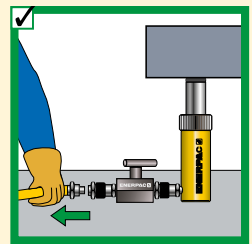
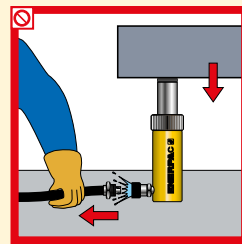

Detach cylinder only when fully retracted or use shut-off valves or safety valves to lock-in cylinder pressure.

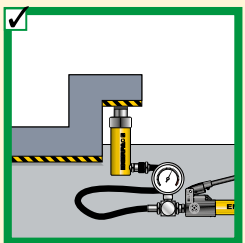
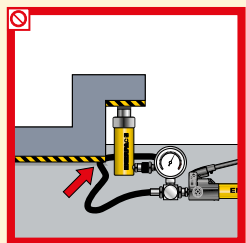

Keep hoses away from the area beneath loads.

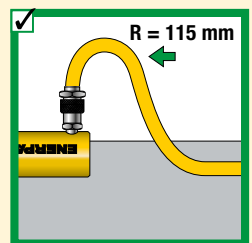
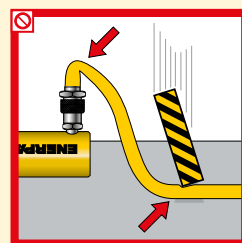

Don't kink hoses. Bending radius should be at least 115 millimetres. Don't drive over or drop heavy objects on hoses.

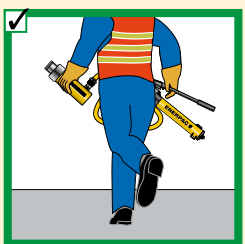

Don't lift hydraulic equipment by the hoses.

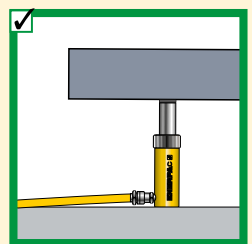
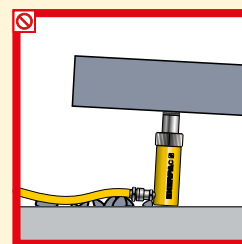

Never allow the cylinder to be lifted off the ground through the couplers.



Function of Bolts and Nuts

Threaded fasteners are used across industry to assemble products ranging from pipelines to heavy-duty earth movers and from cranes to bridges and many more. Their principle function is to create a clamping force across the joint which is able to sustain the operating conditions without loosening.

Correctly tightened bolts make use of their elastic properties, to work well they must behave like springs. When load is applied, the bolt stretches and tries to return to its original length. This creates compressive force across the joint members.

Hooke's Law of Physics

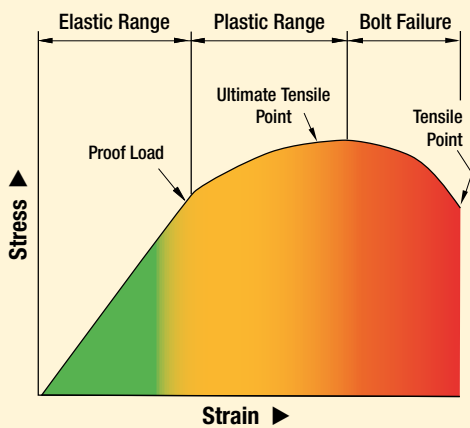

Behavior of Bolts and Nuts

Elasticity is defined in Hooke's Law of physics: The stress in a bolt is directly proportional to its strain. The stress-strain of a bolt has an **elastic range** and a **plastic range**. In the elastic range Hooke's Law is true.

All of the elongation applied within the elastic range is relieved when the load is removed. The amount of elongation increases when more load is applied. When a bolt is stressed beyond its **proof load** (maximum load under which a bolt will behave in an elastic manner), the elastic elongation changes to plastic deformation and the strain will no longer be proportional to the stress.

In the plastic deformation a part of the elongation will remain after the load is removed. The point where this permanent elongation occurs is called the yield strength. The further application of load takes the bolt to a point where it begins to fail this is termed its **ultimate tensile strength (UTS)**. At this UTS-point, if additional force is applied to the bolt it will continue to elongate until it finally breaks. The point at which the bolt breaks is called the **tensile point**.

Careful attention must be paid to the grade of bolt being used as bolt grades differ in the elastic range.

Uniform preload (residual load)

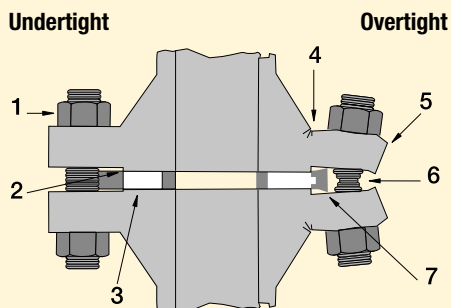

1. Bolt loosens due to cycle loads of vibration.
2. Sealing face surface damage.
3. No compression.
4. Cracking.
5. Flange rotation.
6. Yielding of bolts.
7. Over-compression of gasket

Preload

The main purpose of a bolt and nut is to clamp parts together with the correct force to prevent loosening in operation. The term **preload** refers to the loading in a bolt immediately after it has been tightened.

The amount of preload (residual load) is critical as the joint can fail if the load in the bolt is too high, too low or not uniform in every bolt.

Uneven bolt loads can result in:

- Some bolts being loose while others are overloaded.
- Crushing of the gasket on one side, leakage on the other side.

Preload is normally dictated by the joint design, (see Enerpac Bolted Joint Integrity) for information on common joint types or contact your local representative.



Tightening Methods

Principally there are two modes of tightening: "Uncontrolled" and "Controlled".

Uncontrolled tightening

Uses equipment and/or procedures that cannot be measured. Preload is applied to a bolt and nut assembly using a hammer and spanner or other types of impact tools.

Controlled tightening

Employs calibrated and measurable equipment, follows prescribed procedures and is carried out by trained personnel. There are two main techniques: Torque tightening and Bolt tensioning.

1. Torque tightening

Achieves preload in a bolt and nut assembly via the nut in a controlled manner using a tool.

2. Bolt tensioning

Achieves preload in a bolt and nut assembly by stretching the bolt axially using a tool.

Advantages of Controlled Tightening

Known, controllable and accurate bolt loads

Employs tooling with controllable outputs and adopts calculation to determine the required tool settings.

Uniformity of bolt loading

Especially important on gasketed joints as an even and consistent compression is required for the gasket to be effective.

Safe operation following prescribed procedures

Eliminates the dangerous activities of manual uncontrolled tightening and requires that the operators be skilled and follow procedures.

Reduces operational time resulting in increased productivity

Reduces tightening time and operator fatigue by replacing manual effort with the use of controlled tooling.

Reliable and repeatable results

Using calibrated, tested equipment, following procedures and employing skilled operators achieves known results consistently.

The right results first time

Many of the uncertainties surrounding in-service joint failures are removed by ensuring the correct assembly and tightening of the joint are carried out the first time.



Bolting Integrity Software

A comprehensive on-line software solution for Bolted Joint Integrity.

Integral databases hold data for:

- ASME B16.5, ASME B16.47, API 6A and API 17D flanged joints
- Common gasket materials and configurations
- Comprehensive range of bolt materials
- Comprehensive range of lubricants
- Enerpac's Controlled Bolting Equipment includes: Torque Multipliers, Hydraulic Wrenches and Bolt Tensioners.

Custom Joint information can also be entered.

The software offers Tool selection, Bolt Load calculations and Tool pressure settings, as well as, a combined Application data sheet and Joint completion report.

The screenshot displays the 'Torque Calculation' interface of the Enerpac software. It includes a navigation menu at the top with 'Calculations', 'Inquiries', 'Help', 'Contact Us', and 'Enerpac.com'. The main content area is titled 'Torque Calculation' and features a 'Calculation Information' section with various input fields for flange size, class, material, and joint type. A central diagram shows a cross-section of a bolted joint with dimensions. To the right, there are two tables of 'Diagram Values' and 'Tightening Values'. Below these, there is a 'Tooling Options' list and a 'Selected Tool' section with images of hydraulic wrenches. At the bottom, there is a 'Messages' section.

Bolt Hole Diameter (D)	33mm (1.32")
Flange OD (O)	315mm (12.24")
Bolt Circle Diameter (K)	243mm (9.57")
Total Flange Length (D)	124mm (4.87")
Flange Thickness (S)	34mm (1.32")
Weld Neck OD (N)	152mm (5.98")
Pipe OD (A)	114mm (4.5")

Residual Stress	334 N/mm ²	48398 lbf/in ²
Bolt Load	209956 N	47200 lbf
Torque	1102 Nm	813 ft-lb
Lubricant	a selected as 0.12 (5.12)	

Selected Tool No Tool Selected

Joint Pressure	125mm (4.92")	
(SWS)	125mm (4.92")	
(SWS)	5mm (0")	
Bolts	8 x M13	
Min Bolt Length	215mm (8.32")	
MFT Adj	30mm (1.18")	
Minimum To Seal	254.48 N/mm ² (36898 Psi)	
Yield Stress	274 N/mm ²	
Allowable Stress	613.4 N/mm ²	
% Residual Yield	46%	
Applied Stress	334 N/mm ²	48398 lbf/in ²
Applied Load	209956 N	47200 lbf
% Applied Yield	46%	



Torque Tightening

Turning movement

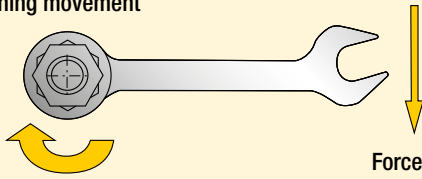

Stretch of Fastener (Pre-load)

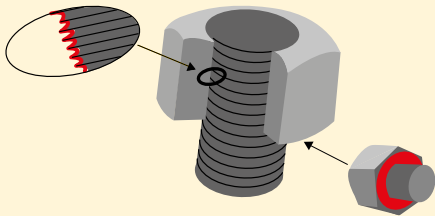
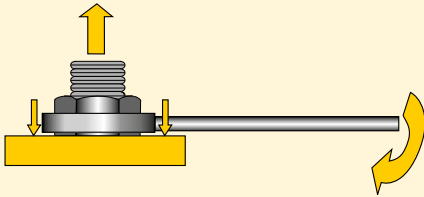

Friction points should always be lubricated when using the torque tightening method.

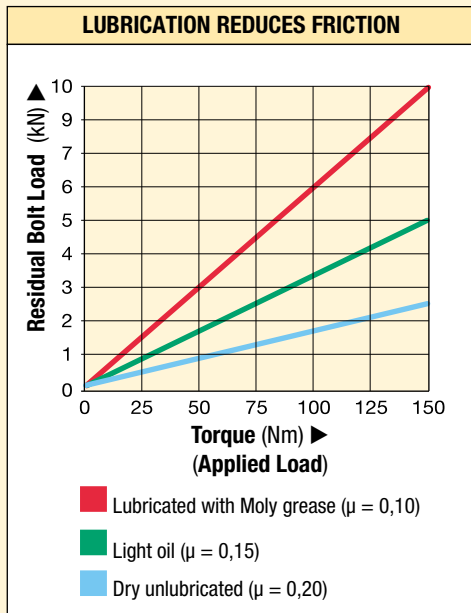

Example of how a lubricant can reduce the effect of friction and convert more torque to bolt preload.

What is Torque?

It is a measure of how much force acting on an object which causes that object to rotate.

What is Torque Tightening?

The application of preload to a fastener by the turning of the fastener's nut.

Torque Tightening and Preload

The amount of preload created when torquing is largely dependant on the effects of friction.

Principally there are three different "torque components":

- torque to stretch the bolt
- torque to overcome the friction in bolt and nut threads
- torque to overcome friction at the nut spot face (bearing contact surface).



Preload (residual load) = Applied Torque minus Frictional Losses

Lubrication Reduces Friction

Lubrication reduces the friction during tightening, decreases bolt failure during installation and increases bolt service life. Variation in friction coefficients affect the amount of preload achieved at a specified torque. Higher friction results in less conversion of torque to preload.

The value for the friction coefficient provided by the lubricant manufacturer must be known to accurately establish the required torque value. Lubricant or anti-seizure compounds should be applied to both the nut bearing surface and the male threads.

Frictional Losses

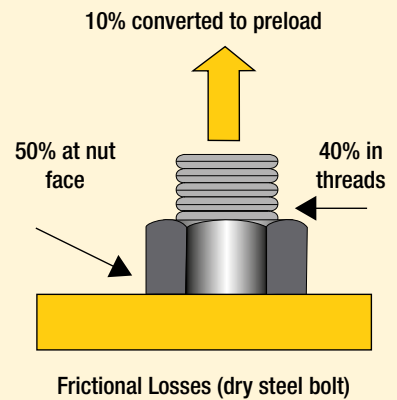



80% Manufacturer's rating of pressure and torque are maximum safe limits. **80%**
 Good practice encourages using only 80% of these ratings!

Torque Procedure

When torquing it is common to tighten only one bolt at a time, this can result in Point Loading and Load Scatter. To avoid this, torque is applied in stages following a prescribed pattern:

Torque Sequence

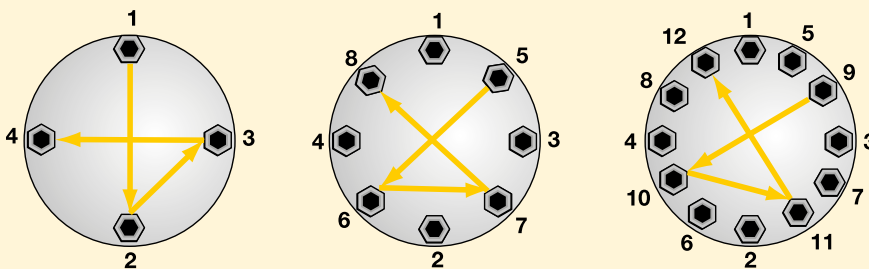

- Step 1** Spanner tight ensuring that 2 - 3 threads extend above nut
- Step 2** Tighten each bolt to one-third ($\frac{1}{3}$) of the final required torque following the pattern as shown above.
- Step 3** Increase the torque to two-thirds ($\frac{2}{3}$) following the pattern shown above.

- Step 4** Increase the torque to full torque following the pattern shown above.
- Step 5** Perform one final pass on each bolt working clockwise from bolt 1, at the full final torque.



Select the Right Wrench

Choose your Enerpac torque wrench using the untightening rule of thumb:

- When loosening a nut or bolt more torque is usually required than when tightening.
- For general conditions it can take up to **2½ times** the input torque to breakout.
- Do not apply more than 75% of the maximum torque output of the tool when loosening nuts or bolts.

Conditions of bolted joints

- Humidity corrosion (rust) requires up to **2 times** the torque required for tightening.
- Sea water and chemical corrosion requires up to **2½ times** the torque required for tightening.
- Heat corrosion requires up to **3 times** the torque required for tightening.

Minimum Output Torque

- The recommended minimum torque value of a hydraulic wrench is 10% of the maximum rated value.



Bolting Integrity Software

A comprehensive on-line software solution for Bolted Joint Integrity.

Integral databases hold data for:

- ASME B16.5, ASME B16.47, API 6A and API 17D flanged joints
- Common gasket materials and configurations
- Comprehensive range of bolt materials
- Comprehensive range of lubricants
- Enerpac's Controlled Bolting Equipment includes: Torque Multipliers, Hydraulic Wrenches and Bolt Tensioners.

Custom Joint information can also be entered.

The software offers Tool selection, Bolt Load calculations and Tool pressure settings, as well as, a combined Application data sheet and Joint completion report.



Breakout Torque

When loosening bolts a torque value higher than the tightening torque is normally required. This is mainly due to corrosion and deformations in the bolt and nut threads.

Breakout torque cannot be accurately calculated, however, depending on conditions it can take up to **2½ times** the input torque to breakout.

The use of penetrating oils or anti-seize products is always recommended when performing breakout operations.



Tensioning requires longer bolts



INCORRECT

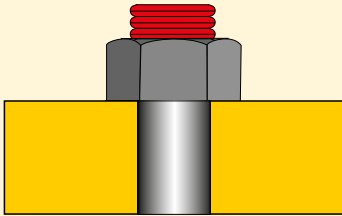

CORRECT

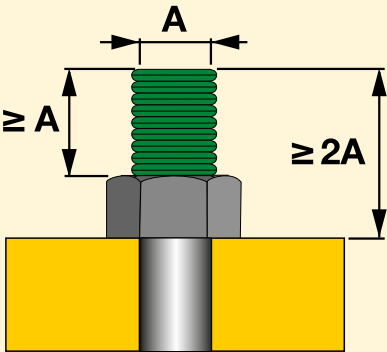

What is Bolt Tensioning?

Tensioning is the direct axial stretching of the bolt to achieve preload. Inaccuracies created through friction are eliminated. Massive mechanical effort to create torque is replaced with simple hydraulic pressure. A uniform load can be applied by tensioning multiple studs simultaneously.

Tensioning requires longer bolts, and a seating area on the assembly around the nut. Tensioning can be done using detachable Bolt Tensioners or Hydraulic Nuts.



Preload (residual load) = Applied Load minus Load Losses

What is Load Loss?

Load loss is a loss of bolt elongation depending on factors such as thread deflections, radial expansion of the nut, and embedding of the nut into the contact area of the joint. Load loss is accounted for in calculation and is added to the preload value to determine the initial **Applied Load**.

The preload depends on Applied Load and Load Loss (load loss factor).



GLOSSARY OF TERMS

Applied Load:

The load applied to a bolt during tensioning which includes an allowance for Load Loss.

Bolt Tensioning:

A method of controlled tightening which applies preload to a bolt by stretching it axially.

Breakout Torque:

The amount of torque required to loosen a tightened bolt. (Usually more torque is required to loosen a bolt than was used to tighten it.)

Elastic Range:

The range on a bolt's stress / strain curve where stress is directionally proportional to strain.

Plastic Range:

The range on a stress / strain curve where the tensile load applied to a bolt results in permanent deformation.

Load Loss:

The losses in a bolt which occur on transfer of load from a tensioning device to the bolt assembly (these may arise from phenomena such as thread deflection and embedding of the nut to the contact area of the joint, and is calculated as a factor of the length to diameter ratio of the bolt).

Load Scatter:

The spread of differing loads in a sequence of bolts after they have been loaded. It is mostly due to the elastic interaction of the bolts and the joint member; as subsequently tightened bolts further compress the joint, previously tightened bolts are subject to some relaxation.

Preload:

The load in a bolt immediately after it has been tightened.

Proof Load:

Proof load is often used interchangeably with Yield Strength but is usually measured at 0,2% plastic strain.

Tensile Point:

The point at which the tensile loading on a bolt causes the bolt to rupture.

Torque Tightening:

The application of Preload to a bolt by turning of the bolt's nut.

Ultimate Strength:

The maximum tension which can be created by tensile load on a bolt.

Yield Strength:

The point at which a bolt begins to plastically deform under tensile loading.

NOTE: Bolt is used as a generic term for a threaded fastener.



80% **Manufacturer's rating of pressure and load are maximum safe limits. Good practice encourages using only 80% of these ratings!** **80%**

Tensioning Operation

Tensioning permits the simultaneous tightening of multiple bolts; the tools are connected in sequence via a high-pressure hose assembly to a single pump unit. This ensures each tool develops the exact same load and

provides a uniform clamping force across the joint. This is especially important for pressure containing vessels requiring even gasket compression to affect a seal.

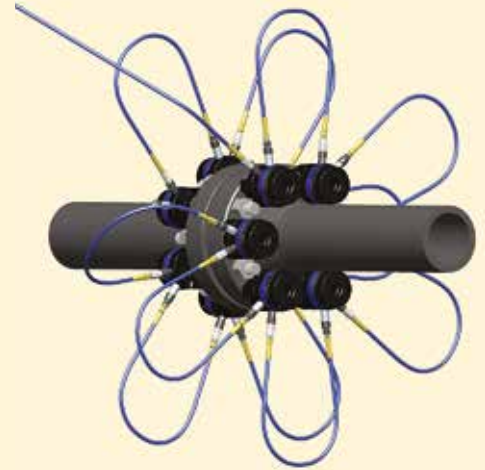

Set-up using a 100% tensioning procedure

All bolts are tensioned simultaneously.

General Procedure

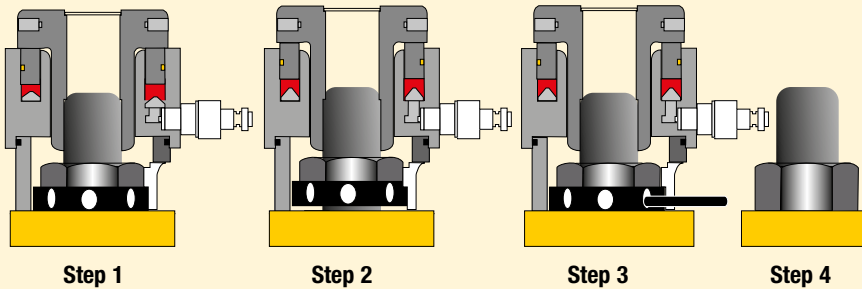

- Step 1:** The bolt tensioner is fitted over the stud.
- Step 2:** Hydraulic pressure is applied to the tensioner which then stretches the stud (bolt).
- Step 3:** The stud's nut is wound down against the joint face

- Step 4:** Hydraulic pressure is released and the tensioner removed. The bolt behaves like a spring, when the hydraulic pressure is released the bolt is under tension and attempts to contract, creating the required clamping force across the joint.

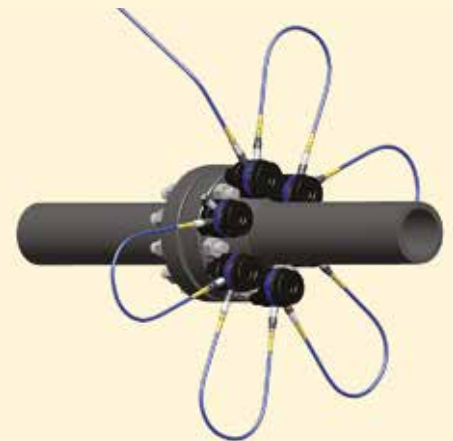

Set-up using a 50% tensioning procedure

Half the bolts are tensioned simultaneously, the tools are relocated on the remaining bolts and they are subsequently tensioned.

Less than 100% Tensioning

Not all applications allow for the simultaneous fit of a tensioning device on each bolt, in these cases at least two tensioning pressures are applied. This is to account for a load loss in those bolts already tensioned as the next sets are tightened.

The load losses are accounted for in calculation and a higher load is applied to allow the first sets to relax back to the target preload.



Read Instruction Manuals

Please refer to the product Instruction Sheets for safe use guidelines and detail on the correct set up and operation of the equipment.



Enerpac Bolting Integrity Software Solutions play a key role in implementing and managing an Integrity Programme for bolted connections. The software is used extensively within Enerpac and increasingly by a wide range of clients worldwide often interfacing with maintenance, construction and commissioning management systems.

- First developed over 20 years ago, we have continued to update and enhance the software based on user feedback, technology advances and our roles on Industry standard committees, to produce the most comprehensive suite of joint integrity software available.
- Recommended bolt loads for standard joints are derived from independently verified calculation methods and traceable back to standards

Integral databases hold data for:

- ASME B16.5, ASME B16.47, API 6A and API 17D flanged joints
- Common gasket materials and configurations
- Comprehensive flange and bolt materials
- Comprehensive range of lubricants
- Enerpac controlled bolting equipment includes torque, multipliers, hydraulic wrenches and bolt tensioners.
- Custom joint information can also be entered.



▲ Standard flange calculation menu (INFORMATE)

The Enerpac Bolting Software Suite includes:

- **Bolt-Up** - Online bolt load calculator. Free access and use on www.enerpac.com.
- **INFORMATE** - Advanced calculation and procedure software. Contact Enerpac for user licenses and dedicated support.
- **IDMS Integrity Data Management System** - A complete Integrity Assurance project management package for managing bolted joints from cradle to grave. Contact Enerpac for user licenses and dedicated support.

Bolt-Up

Bolt-Up is a simple to use online calculator, built upon the Informate calculation engine, providing reliable, repeatable bolt loads for:

- Carbon steel weldneck ANSI 16.5 standard flanges, using a limited range of bolt materials; selected gasket options and a fixed lubrication value.
- Inputting basic joint configuration information allows Bolt-Up to determine: bolt load; bolt stress and the required torque. These outputs are displayed alongside basic flange and bolt information e.g. joint thickness and bolt size/quantity.



Bolting Integrity Software

The software offers Tool selection, Bolt Load calculations and Tool pressure settings, as well as, a combined Application data sheet and Joint completion report.

This software includes following hydraulic tools selections:

- S, W, RSL, DSX and HMT-Series Torque Wrenches,
- HM-Series HydraMax®, GT-Series Bolt Tensioners and EAJ-Series AquaJack Subsea Tensioners.

Software Model Nr.	INFORMATE Subscriptions
BS01PP	Bolting Software 1 person purchase
BS01PAS	Bolting Software 1 person annual support
BS05PP	Bolting Software 5 person purchase
BS05PAS	Bolting Software 5 person annual support

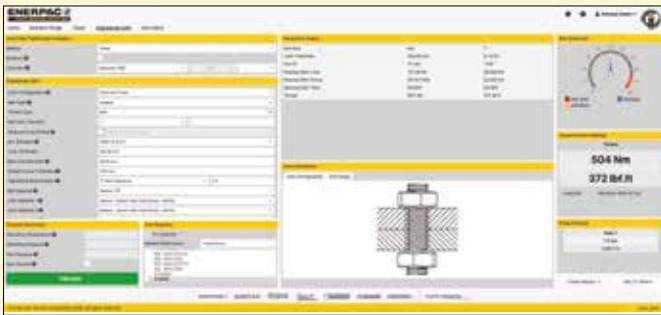

▲ Enginered Joint menu (INFORMATE)

INFORMATE Bolt Load Calculation Software

INFORMATE can be used on a huge range of flanged joints and clamped connections in virtually any situation from process piping to custom-designed flange connections.

- Calculate bolt loads and stresses, determine tooling pressures for Enerpac torque and tensioning equipment; analyse existing connections and test custom designed connections.
- Extensive material database covering all common standards:
 - Common and industry specific lubricants
 - 200+ bolting materials
 - 500+ flange materials
 - 60+ gasket materials
- Enginered Joint Calculation Features - allows for different types of bolted application for non-circular or structural applications.
- Installed direct to the desktop or accessed via the internet, Informate is available in a single version that is configurable to client requirements and includes multiple international standards and the latest and forthcoming regulatory data, when taken with a maintenance package.



▲ Clamp menu (INFORMATE)

Integrity Data Management System (iDMS)

iDMS is a flexible data management and activity planning system specifically for use on assets featuring bolted connections.

Designed to store the entire lifecycle data relating to every critical bolted joint on an installation, it aids planning, ensures joint integrity, as well as reducing construction and maintenance schedules and costs.

- Provides managers and technicians with essential information about joint components used in assembly, in addition it specifies the tools and the torque or tension values to deliver a leak-free joint.
- Allows planner and maintenance engineers to rapidly build packages of work complete with all documentation and then track them to completion
- Whenever a joint is worked on, all of the previous history and experience of that joint is available, allowing any particular requirements of the joint to be taken into account proactively prior to joint assembly and tightening.

iDMS Custom Tailored Solutions available to meet client needs, for example:

- Embedded Informate bolted joint calculator
- Export and import of data to asset management systems
- Exporting data to populate customer documentation
- Colour coding of the joint provides an instant review of the status.

Contact Enerpac for User License



Hexagon Nut and Bolt Sizes

METRIC SIZES

Thread Size D (mm)	Hexagon Size S (mm)	Hexagon Size J (mm)
M10	17	8
M12	19	10
M14	22	12
M16	24	14
M18	27	14
M20	30	17
M22	32	17
M24	36	19
M27	41	19
M30	46	22
M33	50	24
M36	55	27
M39	60	27 (30)
M42	65	32
M45	70	-
M48	75	36
M52	80	36
M56	85	41
M60	90	46
M64	95	46
M68	100	50
M72	105	55
M76	110	60
M80	115	65
M85	120	70
M90	130	70 (75)
M95	135	-
M100	145	85
M105	150	-
M110	155	-
M115	165	-
M120	170	-
M125	180	-
M130	185	-
M140	200	-
M150	210	-

IMPERIAL SIZES

Thread Size D (inch)	Hexagon Size * S (inch)	Hexagon Size J (inch)
5/8	1 1/16	1/2
3/4	1 1/4	5/8
7/8	1 7/16	3/4
1	1 5/8	3/4
1 1/8	1 13/16	7/8
1 1/4	2	7/8
1 3/8	2 3/16	1
1 1/2	2 3/8	1
1 5/8	2 9/16	-
1 3/4	2 3/4	1 1/4
1 7/8	2 15/16	1 3/8
2	3 1/8	1 5/8
2 1/4	3 1/2	1 3/4
2 1/2	3 7/8	1 7/8
2 3/4	4 1/4	2
3	4 5/8	2 1/4
3 1/4	5	2 1/4
3 3/4	5 3/4	2 1/4

* Heavy hexagon nuts.



Determine the maximum torque according to the bolt (nut) size and grade. Always consult the manufacturers instructions or engineering recommendations when making bolted connections.



IMPORTANT

The hexagon sizes shown in the tables should be used as a guide only. Individual sizes should be checked before specifying any equipment.



BSH-Series Sockets

Use only Heavy Duty Impact Sockets for power driven torquing equipment, according to ISO2725 and ISO1174;

DIN3129 and DIN3121 or ASME-B107.2/1995.



Key to measurements

All capacities and measurements in the catalog are expressed in uniform values. The conversion chart provides helpful information for their translation into equivalent systems.

FDM Conversion Chart		
Inches	Decimal	mm
1/16	0,06	1,59
1/8	0,13	3,18
3/16	0,19	4,76
1/4	0,25	6,35
5/16	0,31	7,94
3/8	0,38	9,53
7/16	0,44	11,11
1/2	0,50	12,70
9/16	0,56	14,29
5/8	0,63	15,88
11/16	0,69	17,46
3/4	0,75	19,05
13/16	0,81	20,64
7/8	0,88	22,23
15/16	0,94	23,81
1	1,00	25,40

Pressure:

1 psi	= 0,069 bar
1 bar	= 14,50 psi
	= 10 N/cm ²
1 kPa	= 0,145 psi
1 MPa	= 145 psi

Force:

1 lbf	= 4,45 N
1 klbf	= 1000 lbf
1 kN	= 1000 N
1 kgf	= 9,8 N

Weight:

1 pound (lb)	= 0,4536 kg
1 kg	= 2,205 lbs
1 metric ton	= 2205 lbs
	= 1000 kg
1 ton (short)	= 2000 lbs
	= 907,18 kg

Temperature:

To Convert °C to °F:
 $T^{\circ}\text{F} = (T^{\circ}\text{C} \times 1,8) + 32$

To Convert °F to °C:
 $T^{\circ}\text{C} = (T^{\circ}\text{F} - 32) \div 1,8$

Volume:

1 in ³	= 16,387 cm ³
1 cm ³	= 0,061 in ³
1 liter	= 61,02 in ³
	= 0,264 gal
1 US gal	= 3,785 cm ³
	= 3,785 l
	= 231 in ³

Other measurements:

1 inch	= 25,4 mm
1 mm	= 0,039 in
1 ft	= 0,3048 m
1 m	= 3,2808 ft
1 in ²	= 6,452 cm ²
1 cm ²	= 0,155 in ²
1 hp	= 0,746 kW
1 kW	= 1,340 hp
1 Nm	= 0,738 Ft.lbs
1 Ft.lbs	= 1,356 Nm
1 kN	= 224,82 lbs

Torque Conversion Factors

Units to be converted	International System - S.I. (Nm)	Imperial (Lbf.ft)	Metric (kgf.m)
1 Ft.lbs	1,356	1,000	0,138
1 Nm	1,000	0,738	0,102
1 kgf.m	9,807	7,233	1,000



Bolting Integrity Software

A comprehensive on-line software solution for Bolted Joint Integrity.

Integral databases hold data for:

- ASME B16.5, ASME B16.47, API 6A and API 17D flanged joints
- Common gasket materials and configurations
- Comprehensive range of bolt materials
- Comprehensive range of lubricants
- Enerpac's Controlled Bolting Equipment includes: Torque Multipliers, Hydraulic Wrenches and Bolt Tensioners.

Custom Joint information can also be entered.

The software offers Tool selection, Bolt Load calculations and Tool pressure settings, as well as, a combined Application data sheet and Joint completion report.



Enerpac Demo-Van

Offering full bolting tool service and maintenance wherever you need it. We provide you with personalized bolting demonstrations and training, and the bolting

service vehicle is equipped to perform torque wrench and other equipment calibrations and repairs on site.

We can give you advice on the best solutions and the bolting tools that are most suited to your application, thus enabling safe and controlled performance of your bolting activities.

- On-site demonstrations of Enerpac bolting tools
- Repair and calibration services
- Training for the safe and efficient use of Enerpac bolting tools

Schedule a Bolting Service Demonstration

Use the distributor search at enerpac.com to find the nearest Enerpac bolting service van to schedule a demonstration. These distributors display the bolting service icon.



At Enerpac, we are committed to safety

Unfortunately, serious incidents can happen on a job site. Nevertheless, such mishaps may be avoidable if workers pay attention to the hazards and potential

risks, and know how to use tools correctly. Whether you work in maintenance or production, power plant, shipyard, mine, shop floor or construction site; learning to use hydraulic tools safely is mandatory.

Our Goal Zero initiative is part of our global commitment to improve workplace safety. We are committed to achieve the Goal of Zero harm to customers and end-users of our products.

Worldwide Catalogue Coverage

Enerpac Catalogues are printed in many languages. If your requirements call for product use in a different country, please send your request to the applicable country listed on www.enerpac.com – the Enerpac catalogue of the country serving your specific market area will be forwarded promptly.



E330e



9844



E215e

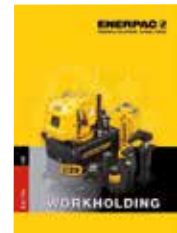

E330e Industrial Tools Catalogue

This 420 pages catalogue contains our full line of cylinders, pumps, valves and system components, presses, pullers, tools, cutters, bolting tools, flange maintenance tools, heavy lifting technology and on-site machining tools.

9844 Capability Brochure Heavy Lifting Technology

Enerpac's Heavy Lifting Technology provides solutions to meet customer requirements for safe, precise control of movement and positioning of heavy loads.

E215e Workholding Catalogue

Offers innovative products and solutions to provide powerful clamping and positioning force to every type of manufacturing process. Workholding solutions increase product quality and production output.

Enerpac Academy & Enerpac Maintenance Program



Do you work with high-pressure hydraulic tools regularly or even every day? Operating such tools requires sound knowledge of how they work and this should be maintained.

Effective use of these tools boosts safety and reduces risk - both for you as the operator and for the environment within which the tools are used. Having the right training will enable you to use the tools safely and properly.

Enerpac Academy is our in-house training centre, set up exclusively for Enerpac business partners, Enerpac users and Enerpac employees: training programs ranging from tool expertise, repairs and maintenance, to safe operation of high-pressure hydraulic tools.

Putting theory into practice

The training courses are interactive and benefit from a highly diverse program that puts the covered theory into practice right away. Our training services are grounded in many years of experience in providing and applying Enerpac tools.

Tailored training

Enerpac Academy offers you the exclusive opportunity to train your (new) employees in making proper use of Enerpac tools. Our trainings can also be done on-site.

Safety training

Safe use of Enerpac high pressure hydraulic tools, user and environmental safety.

Controlled bolting trainings

Bolting tool theory, tool applications, hands-on training on safe and efficient use of torque wrenches, tensioners and pumps.

General hydraulic sales training

Knowledge of hydraulics, hydraulic tools and applications. Tool repair training: Repair and maintenance of general Enerpac tools.

Application training

Tool feature and benefits, tool application review, safe use of hydraulic tools and market information.



Enerpac Academy – The Power of Knowledge

- Specialist in-house Enerpac training center
- Standard and tailored training programs
- Highly experienced trainers
- Selection of training courses with a proven (value adding) track record
- Knowledge and experience sharing
- User and tool safety come first.

Training Centre Locations

- Ede (The Netherlands)
- Bangalore (India)
- Columbus, Wisconsin (USA)
- Perth (Australia)
- Singapore



EMP – Enerpac Maintenance Program

EMP is a preventive maintenance program. Your Enerpac Authorized Service Centre will check the tools on essential points: leaking, oil level and quality, maximum pressure setting, and damage. EMP reduces operational risks, increases safety and minimises extremely expensive delays in your operations. You will be advised about regular maintenance of the Enerpac tools.

- Work more safely
- Minimise operational risk
- Ensure tools are always available and in tip-top shape
- As good as new after repair
- Prevent downtime
- Advice on safe and effective use
- Maintenance when tools are not used.

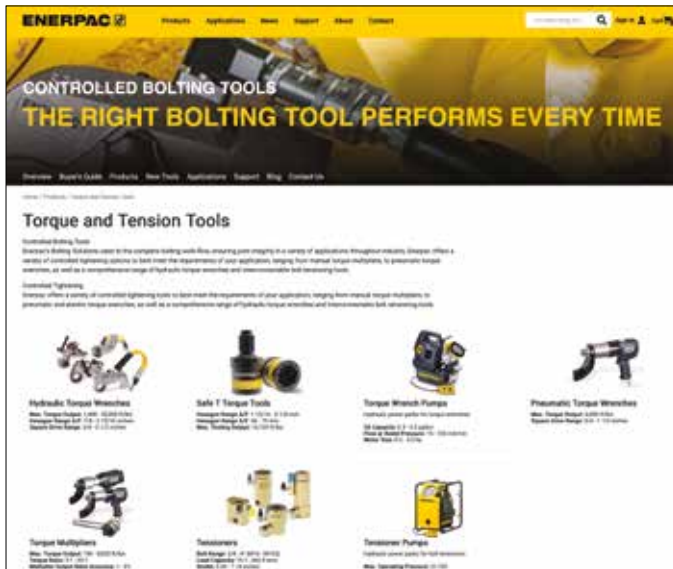

Enerpac is the leading global provider of high-pressure hydraulic tools and solutions with a broad range of products, local expertise and worldwide distribution network. With a proven track record in a wide range of markets, Enerpac designs and manufactures high-quality tools and solutions for all industrial applications.

Enerpac has gained unique experience in delivering hydraulic solutions for the controlled movement and positioning of heavy objects. Enerpac supports your business by offering the right solutions and service to help you get your work done efficiently and safely.

www.enerpac.com

- Online Bolting Calculator
- Learn more about hydraulics
- Promotions
- New products
- Electronic Catalogues
- Trade shows
- Manuals (instruction & repair sheets)
- Nearest Distributors & Service Centers
- Enerpac products in action
- Heavy Lifting Technology

Ordering Products and Catalogues

To find the name of the closest Enerpac distributor or service center, to request literature or technical application assistance, contact Enerpac at one of the addresses on the next page or pose your question through E-mail: info@enerpac.com

While every care has been taken in the preparation of this catalogue and all data contained within is deemed accurate at the time of printing, Enerpac does reserve the right to make changes to the specifications of any product, or discontinue any product, contained within this catalogue without prior notice.

All illustrations, performance specifications, weights and dimensions reflect the nominal values and slight variations may occur due to manufacturing tolerances. Please consult Enerpac if final dimensions are critical.

All information in this catalogue can be changed due to product improvements without prior notice.

© Copyright 2022, Enerpac. All rights reserved. Any copying or other use of material in this catalogue (text, illustrations, drawings, photo's) without express written consent is prohibited.

Model Number Index & Enerpac Worldwide Locations

A	Page:
A	101
AOT	5
ATM	102-103
ATP	96
B	
B, BH	83
BLT	53
BSH	8
BSO	142
BUS	9, 26, 34, 36
BW	93
C	
CM	109
D	
DDA	40
DSA	53
DSX	38-40, 55
E	
E	48-49, 55, 58-59
EAJ	82-83
ED	53
EP	58-59
ERA	33, 53
ERT	33
F	
FC	125
FF	110-111
FFL	110
FRL	50-51
FSB	104-105
FSC	104-105
FSF	110
FSH	104-105
FSM	104-105
FSS	110
FTE	88-89
FTR	86-87
G	
GA	97, 99, 102, 109
GA45	97, 102, 109
GF	99
GP	99, 102
GT	80-81
H	
HC	99, 109
HF	100
HLP	44-45
HM	76-79
HMT	42-47, 55
HP	126
HN	91
HPT	92
HSQ	46-47
HT	93
L	
LAT	55, 68-69
LW	97
M	
MCS	54
MG	112-113
MITT	130-131
MP	130
MST	90

N	Page:
NC	106-107
NSH, NSP	108-109
P	
P	97, 99, 101, 105-106, 109
PGT	84-85
PTW	50-53
PUD	109
R	
RAT	53
RC	97-98, 100
RCH, RCS	97-98
RLP	27-32
RSL	26-37, 55
RSM	97
RSQ	36-37
RTE	7
S	
S	4-7, 55
SB	64, 72, 104-105
SC	97, 99
SD, SDA	5-6
SG	112, 118-120
SLR	53
SLW	97
SRA	6, 53
SRS	7, 97
STF	105
STN	106
STTL	10-11
SW	104-106
SWH	4, 12, 22, 38
SWi	112, 114-117
SWR	97
T	
TFA	124
TH, THQ	100
TR	100
TSP	4, 7, 12, 22
TWM	33
TQ	55, 60-61
V	
VC	112, 122-123
W	
W	12-24, 55
WTE	24
WR	97, 101
WRP	24
W-SL	22-23
X	
XA	99, 109
XC	55-57, 99, 109
Z	
ZA	55, 70-75
ZE	55, 66-67
ZHE	64
ZRC	64, 72
ZTM	64, 72
ZUTP	94-95
ZU4T	55, 62-65
00	
67	121, 123
144	126
302	126

Australia and New Zealand
 Actuant Australia Pty Ltd.
 3 Orion Rd, Jandakot, WA 6164, Australia
 Tel: +61 287 177 200
 Fax: +61 297 438 648
 Australia Toll Free: +1800 225 084
 New Zealand Toll Free: +0800 363 772

Brazil
 Power Packer do Brasil Ltda.
 Rua Luiz Lawrie Reid, 548
 09930-760 - Diadema (SP)-Brasil
 Tel: +55 11 5687 2211
 Toll Free: 0800 891 5770

China (Taicang)
 Actuant (China) Industries Co.Ltd.
 No. 6 Nanjing East Road,
 Taicang Economic Dep Zone, Jiangsu, China
 T +86 0512 5328 7500
 F +86 0512 5335 9690
 Toll Free:
 T +86 400 885 0369

Enerpac Heavy Lifting Technology B.V.
 Zuidelijke Havenweg 3,
 7554 RR Hengelo
 P.O. Box 421,
 7550 AK Hengelo,
 The Netherlands
 T +31 74 242 20 45
 F +31 74 243 03 38

France and French speaking Switzerland
 ENERPAC France S.A.S
 6 rue du 4 septembre,
 Immeuble Le Poversy,
 Bâtiment B - 6ème étage,
 92130 Issy-les-Moulineaux, France
 Tel: +33 1 60 13 68 68
 Fax: +33 1 69 20 37 50

Germany, Austria and German speaking Switzerland
 Actuant GmbH
 Boelckestrasse 21-23
 D-50171 Kerpen, Germany
 T +49 (0)2237 92301-0
 F +49 (0)2237 92301-180

Central and Eastern Europe, Russia, Baltic States and CIS countries
 Enerpac Eastern Europe Sp. z o.o.
 Krakowska Street 280,
 building: Eximius Park 200, floor 1,
 32-080 Zabierzów, Poland

India
 Enerpac India Private Limited
 No. 10, Bellary Road, Sadashivanagar,
 Bangalore, Karnataka - 560 080 India
 T +91 80 3928 9000

Italy, Greece and Turkey
 ENERPAC S.p.A.
 Via Leonardo da Vinci, 97
 20090 Trezzano sul Naviglio (Milano)
 Italy
 T +39 02 4861 111
 F +39 02 4860 1288

Japan
 Enerpac Co., Ltd.
 Besshocho 85-7
 Kita-ku, Saitama-shi 331-0821, Japan
 T +81 48 662 4911
 F +81 48 662 4955

Middle East, North Africa and Caspian Sea Countries
 ENERPAC Middle East FZE
 Swiss Tower, Office 902, Cluster Y,
 Jumeirah Lake Towers,
 Dubai-United Arab Emirates
 Tel: +971 4 527 0700

Norway
 ENERPAC AS
 Kirkegata 3, NO-2000, Lillestrom
 P.O. Box 3051, NO-2028, Lillestrom, Norway
 Tel: +47 91 578 300

Southeast Asia, Hong Kong and Taiwan
 Actuant Asia Pte Ltd.
 25 Pandan Crescent,
 #05-11/12/13 Tic Tech Centre
 Singapore 128477
 T +65 68 63 0611
 F +65 64 84 5669
 Toll Free:
 T +1800 363 7722

South Korea
 Actuant Korea Ltd.
 48, Mayu-ro, 20-beon-gil, Shiheung-si
 Gyeonggi-do, 15116 South Korea
 T +82 31 434 4506
 M +82 (0)10 7134 4508

Spain and Portugal
 ENERPAC SPAIN, S.L.
 Avenida Valdelaparra N° 27 3ª - L8
 28108 Alcobendas (Madrid), Spain
 T +34 91 884 86 06
 F +34 91 884 86 11

South Africa and other English speaking African countries
 ENERPAC AFRICA (PTY) Ltd.
 Cambridge Office Park, Block E
 5 Bauhinia Avenue
 Highveld Techno Park, Centurion 0157
 Republic of South-Africa
 T 0027 (0) 12 940 0656

Sweden, Denmark, Finland and Iceland
 Enerpac Scandinavia AB
 Box 83, 82222 Alfva, Sweden
 Tel: +46 (0) 415 000

The Netherlands, Belgium, Luxembourg
 ENERPAC B.V.
 Galvanistraat 115, 6716 AE Ede
 P.O. Box 8097, 6710 AB Ede,
 The Netherlands
 T +31 318 535 911
 F +31 318 535 848

United Kingdom and Ireland
 ENERPAC UK LTD
 5 Coopies Field
 Morpeth, Northumberland
 NE61 6JR, England
 T +44 800 1380500
 F +44 1670 5016 51

USA, Latin America and Caribbean
 ENERPAC World Headquarters
 P.O. Box 3241
 Milwaukee, WI 53201-3241 USA
 N86 W12500 Westbrook Crossing
 Menomonee Falls, Wisconsin 53051
 T +1 262 293 1600
 F +1 262 293 7036
 User inquiries:
 +1 800 433 2766
 Distributor inquiries/orders:
 +1 800 558 0530
 +1 800 628 0490



CONTROLLED TIGHTENING and LOOSENING

Hydraulic Square Drive Torque Wrenches
Hydraulic Hexagon Torque Wrenches
Manual Torque Multipliers
Pneumatic Torque Wrenches
Mobile Calibration Stand

Page 4-54



TORQUE PUMPS

Cordless Torque Pumps
Electric Torque Pumps
Air Driven Torque Pumps

Page 55-73



TENSIONING TOOLS and PUMPS

Bolt Tensioners
Tensioning Hand Pump
Electric Tensioning Pumps
Air Driven Tensioning Pumps
Hoses and Couplers

Page 76-96



JOINT ASSEMBLY, POSITIONING and SEPARATION

Cylinder-Pump Sets
Spread Cylinders
Flange Alignment Tools
Flange Spreaders
Nut Cutters

Page 97-111



FLANGE MAINTENANCE TOOLS

Flange Spreading Tools
Flange Pulling Tools
Valve Change-Out Tools
Wind Tower Flange Alignment Tools
Portable Machining Products

Page 112-129



YELLOW PAGES

Safety Instructions
Tightening & Tensioning Theory
Bolting Integrity Software Solutions
Enerpac Demo Van
Enerpac Maintenance Program

Page 132-147

ENERPAC

www.enerpac.com